

Metro Aluminum Products is an entirely Canadian owned company manufacturing and distributing Architectural Aluminum Glazing Systems that utilize Canadian manufactured aluminum extrusions and finishes.

With our head office and main manufacturing facility in Surrey, British Columbia and a satellite warehouse located in Calgary, Alberta, Metro Aluminum is the supplier by choice, to the majority of glazing contractors throughout Western Canada.

Metro Aluminum is an innovative company with an on-going commitment to improve and expand its product line to meet industry changes and standards. Metro Aluminum is dedicated to providing the the best possible quality and service to our customers at prices that are always competitive.

Locations and Contact Information

Web Site: www.metroaluminum.com

Head Office, Sales and Manufacturing
19045 – 24th Avenue,
Surrey, B.C. V3S 3S9
Telephone 604-535-5316 / Toll Free 877-535-5316
Fax 604-535-5319 / Toll Free 877-535-5315
Email: info@metroaluminum.com



Alberta Manufacturing
261108 Wagon Wheel Way.
Rocky View County, Alberta, T4A 0E3
Telephone 403-735-5014
Fax 403-291-2695
Email: info@metroaluminum.com



ARCHITECTURAL ALUMINUM CATALOGUE

SWING DOORS & HARDWARE SECTION **A**

SLIDING DOORS & HARDWARE SECTION **B**

STOREFRONT FRAMING SECTION **C**

CURTAIN WALL SECTION **D**

STRIP WINDOW SECTION **E**

OPERABLE WINDOW & HARDWARE SECTION **F**

SKYLIGHT - SLOPED GLAZING SECTION **G**

MISCELLANEOUS SECTION **H**

- 
- 01 - General Specifications
 - 02 - Door Construction Details
 - 03 - 250 Series - Narrow Stile Door
 - 04 - 250T Series - Thermally Broken Narrow Stile Door
 - 05 - 350 Series - Medium Stile Door
 - 06 - 350T Series - Thermally Broken Medium Stile Door
 - 07 - 500 Series - Wide Stile Door
 - 08 - 500T Series - Thermally Broken Wide Stile Door
 - 09 - Door Rail - Options
 - 09A - Door Rail - Thermally Broken Options
 - 10 - Glacier 2000 - Residential Thermally Broken Door
 - 13 - Door Hardware

Part 1 - GENERAL

Scope - The doors shall be _____ as manufactured by METRO ALUMINUM Products Ltd. Supply and install aluminum doors, as described on the architectural drawings and as specified herein.

Work Not Included - See: Specifier's lists of excluded items; Items furnished but not installed and/or Items installed but not furnished.

Related Work Specified Elsewhere - See: Specifier's lists and related Sections.

Design & Performance Requirements - Doors to fully comply with applicable standard specifications as typically referenced to the following performance requirements criteria: Air Tightness, Water Tightness, Wind and Other Load resistance, Temperature Index and Energy Performance. (Specifier's selection)

Submittals - Shop Drawings & Samples - Submit all documentation and samples for review by Consultant at one time, prior to fabrication of door products.

Quality Assurance - Provide all necessary information to show that all involved products meet or exceed the requirements of these specifications.

Delivery, Storage and Handling - Deliver, store, handle, protect and schedule materials and products so as to avoid any damage. Follow recommendations of AAMA CW-10 "Care and Handling of Architectural Aluminum from Shop to Site" and others as applicable.

Part 2 - PRODUCTS

Materials - All materials to meet the minimum design and materials specifications as applicable. Any defects impairing strength, durability or appearance are not acceptable. Extruded aluminum shall be AA 6063 T6 alloy and temper - Fy = 110 MPa (16 KSI) minimum.

Sufficient strength and size fasteners shall be made of corrosion-resistant and compatible material such as cadmium or zinc plated carbon steel, stainless steel or aluminum, to prevent any galvanic action (electrolytic corrosion). Standard weathering at perimeter frame shall be pile cloth with a vinyl fin - minimum, or an extruded thermoplastic elastomer tubular profile with a semirigid setting key (Specifier's selection). Optional weathering at the bottom rail shall be a sweep blade type strip secured with concealed fasteners. Dry glazing method to utilize extruded dense Neoprene, EPDM, or other equal material; spline (and/or wedge) gaskets set into extruded aluminum stops. Gasket profile shall be designed and sized to fit tight and properly seal glass-metal interfacing. Glass setting to be compatible with glass unit seals and/or other parts involved as required.

System Description - Door System shall be type out-swing/in-swing _____. METRO Series for single glass (for sealed insulating glass units), uninsulated (insulated) - Specifier selection - as manufactured by METRO ALUMINUM Products Ltd.

Reference minimum thickness of extruded metal shall be: Frame 3 mm (0.12") and Glazing Stop 1.3 mm (0.05") minimum.

Frame nominal dimensions of extruded metal shall be:

Depth of frame	_____
Width of stile	_____
Height of top rail	_____
Height of middle rail	_____
Height of bottom rail	_____

Glass retention, as for dry glazing method, shall be achieved by extruded aluminum glazing stop profile and inorganic rubber gasket. Whenever substitute/alternative products are considered, supporting data to be submitted ten (10) days prior to bid date to allow for valid comparison. Approval of alternates to be confirmed in advance of bid closing by addendum only.

Fabrication - Tubular profiles of rails and stiles shall be accurately fabricated and assembled to provide tight fit hairline joints only. Corner joinery shall utilize assembly spigot-bracket. Parts involved shall be fastened by means of anticorrosive steel screws and bolts with additional securing welds to allow for permanent true and square set of frame elements. Extruded aluminum square glazing stops, equipped with hollow gaskets, shall secure glass on both sides. Specified hardware shall be connected accurately to aluminum framing as per manufacturer's specifications. No exposed fasteners are permitted. Each door leaf to be equipped with adjusting mechanism, set at the top rail, to allow for necessary installation adjustments. Both stiles of centre hung single door, hinge and meeting stile (1) sides of centre hung pair doors shall be furnished with hard-backed poly pile weather-stripping, as required. Perimeter frame of offset pivoted (or butt hung) doors to have weather-strip stops at jamb and head. Active meeting stiles of pairs to be furnished with matching weather-strip device set and secured in appropriate reveal-groove. Bottom rail to receive weather-strip sweep as required.

Finish - All exposed surfaces shall be finished as specified. The finish, as per AAM designation, shall be (Specifier's selection):

Standard clear anodizing to AA - M12C22A31
Standard perma bronze to AA - M12C22A44
Standard black anodizing to AA - M10C21A44
Duracron acrylic enamel to AA - M12C4XR1X
Custom paint qualities and colors - Specifier's selection.
Hardware to have manufacturer's standard finish.

Hardware - Hardware shall be supplied by METRO ALUMINUM Products Ltd. for factory installation, and to include: (Specifier's selection):

Top and bottom offset pivots.
Intermediate offset pivots where required, or
1 pair or 1.5 pairs of 100 mm x115 mm (4" x 4.5") butt hinges, or
Centre hung pivots compatible with centre hung closers.
Push-pull - Metro standard.
Door closers - streamline or concealed.
Standard 150 mm (6") threshold with reinforced pivot anchor point.
Panic device. Various types available - Specifier's selection.
Alternative hardware clause: Hardware as specified under separate section of the Specifications. The manufacturer shall furnish all necessary templates for assembly and installation.

Part 3 - EXECUTION

Installation - Doors to be installed in prepared openings, at correct locations as shown on drawings, set level, plumb, square and aligned with other work in accordance with manufacturer's instructions, approved shop and erection drawings. Operating hardware, checked and adjusted as required, shall be left in ready for use condition. Perimeter joints to be sealed/caulked as specified and detailed to ensure weathertight assembly.

Protection and Cleaning - Work to be protected from damage during and after installation. Consult with manufacturer and installer to determine appropriate protective measures. The General Contractor shall be responsible for protection during construction and for final cleaning. After installation, aluminum work and glass to be cleaned according to instructions/manuals provided by product manufacturers and glaziers. Use appropriate cleaning materials and methods. Do not scratch or damage glass or finishes.

Note: The above Specifications should relate to The Product Specifications by METRO ALUMINUM Products Ltd. as applicable to the specific door types such as: 250, 350 and 500 Series.

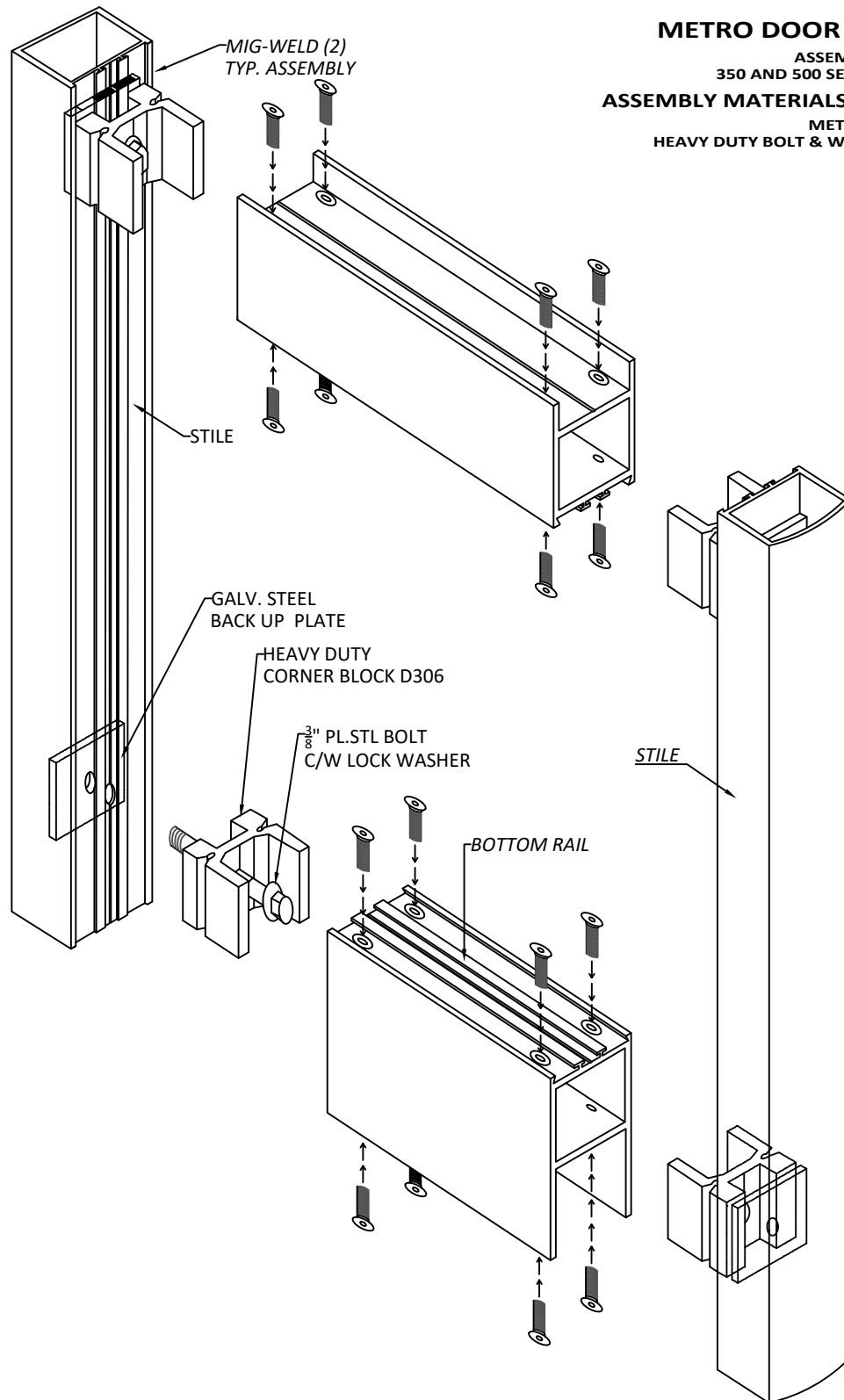

METRO DOOR 250 SERIES
ASSEMBLY DETAILS FOR
350 AND 500 SERIES ARE SIMILAR
ASSEMBLY MATERIALS & METHODS
METRO'S STANDARD -
HEAVY DUTY BOLT & WELD CONNECTION



Our 250 Narrow Stile Door, the top choice for commercial applications, is renowned for its durability, versatility, functionality, and aesthetic appeal, making it an excellent choice for any business environment. Key features include:

- **Narrow Stile Design:** A sleek and modern appearance suitable for various architectural styles.
- **Single or Double Glazed Stops:** Accommodates different glazing configurations for enhanced performance and design flexibility.
- **Compatibility with Metro Framing:** Seamlessly integrates with Metro framing systems for a cohesive installation.
- **Mid and Bottom Rails:** Available in various sizes to meet your specific design and functionality requirements. (see page A-08 for details)
- **Welded Corners:** Each corner is welded & bolted for enhanced structural integrity.

Standard hardware includes: (see pages A-13 - A-13F)

- Offset Pivots
- Construction Security Lock (Exterior)
- Thumb Turn (Interior)
- Metro Standard Push Bar/Pull Handle
- ½ Inch Threshold
- Exposed Closer

Works with hinging hardware options, including:

- Continuous Hinges
- Butt Hinges
- Center Hung / Walking Beam Pivots

Compatible with most hardware options, including:

- Concealed Closer's
- Apartment Packages (Lever / Paddle)
- Offset D-Pulls and Ladder Pulls

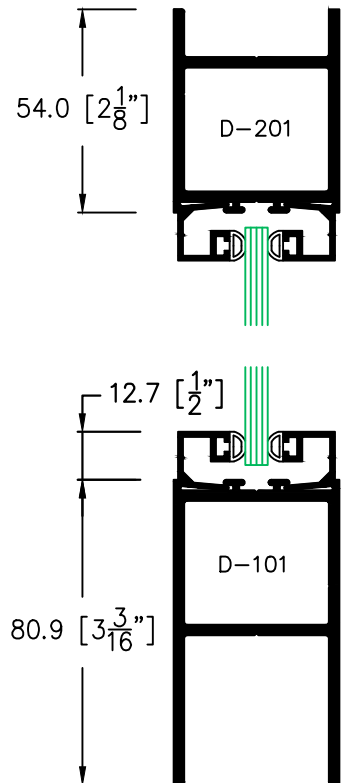
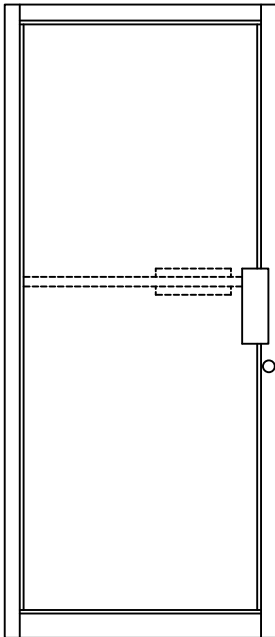

SINGLE GLAZED

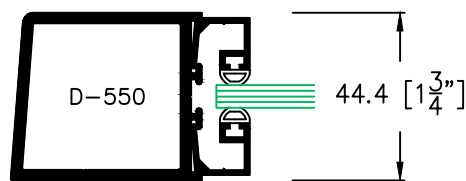

50.8 [2"]

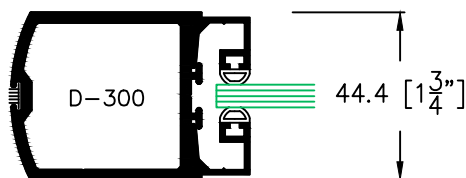

50.8 [2"]

DOUBLE GLAZED

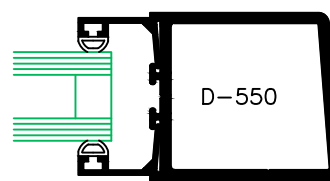

SINGLE ACTING

19.0 [3/4"]

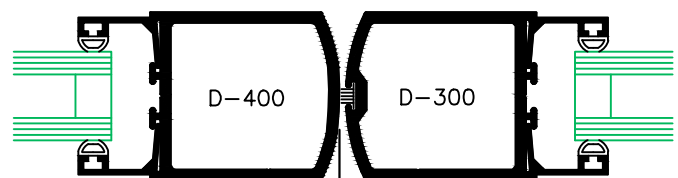

DOUBLE ACTING

50.8 [2"]

250 SERIES DOOR - 1750 SERIES FRAMING

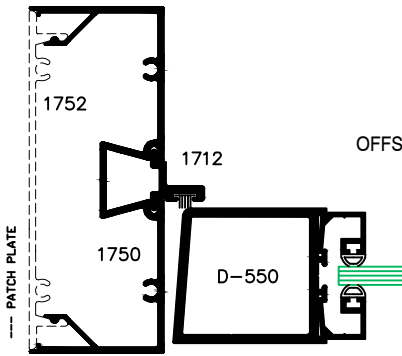
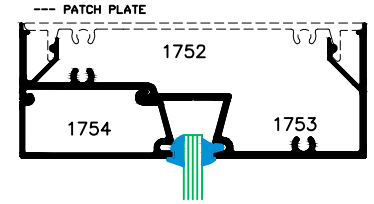
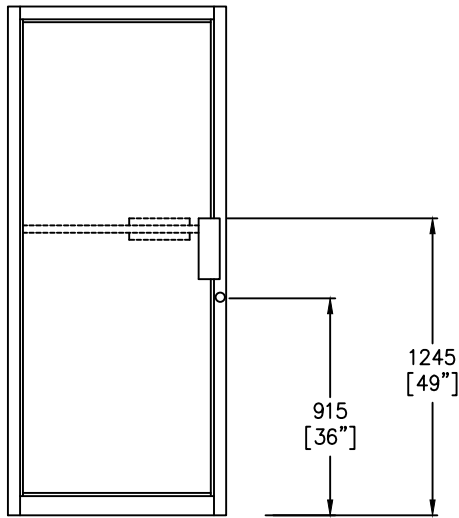

OFFSET HUNG

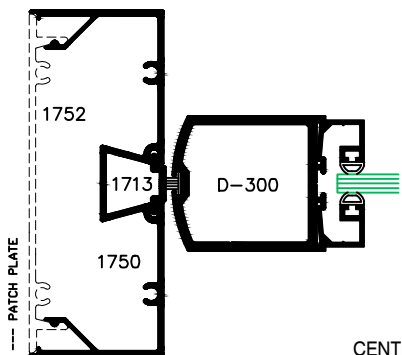
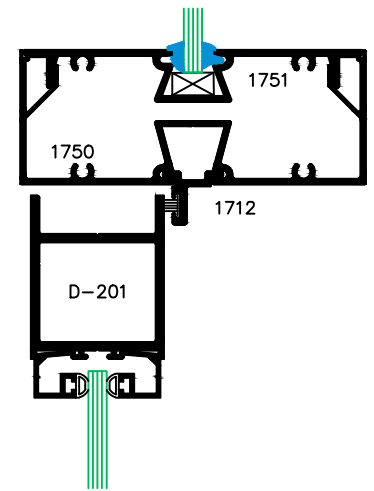
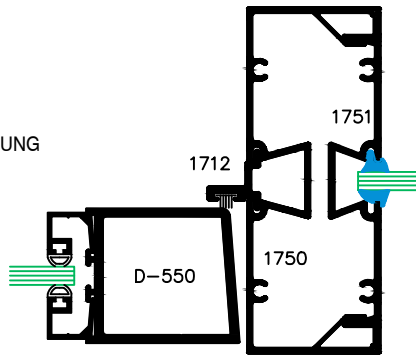

CENTER HUNG

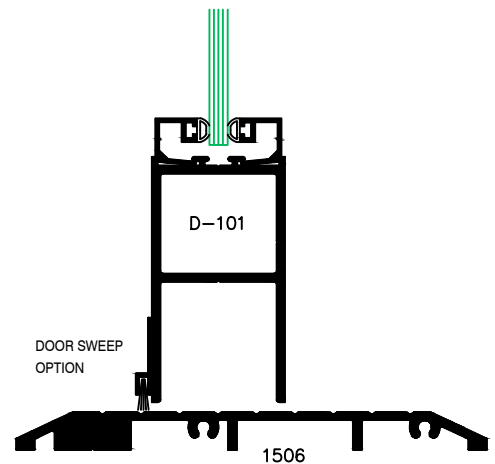
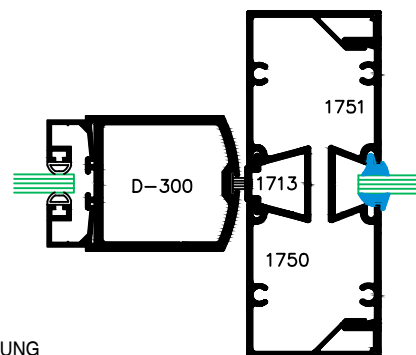

VARIOUS THRESHOLD OPTIONS
ARE AVAILABLE

250 SERIES DOOR - 2050 SERIES FRAMING

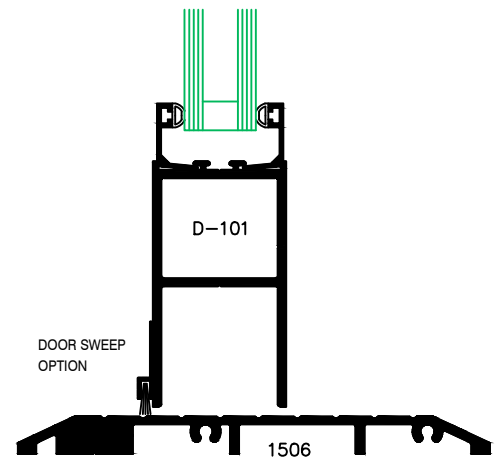
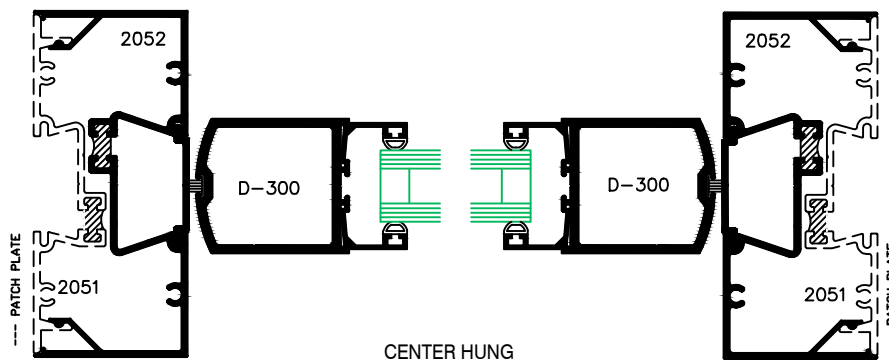
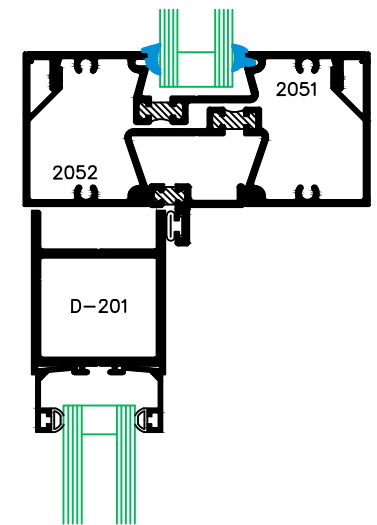
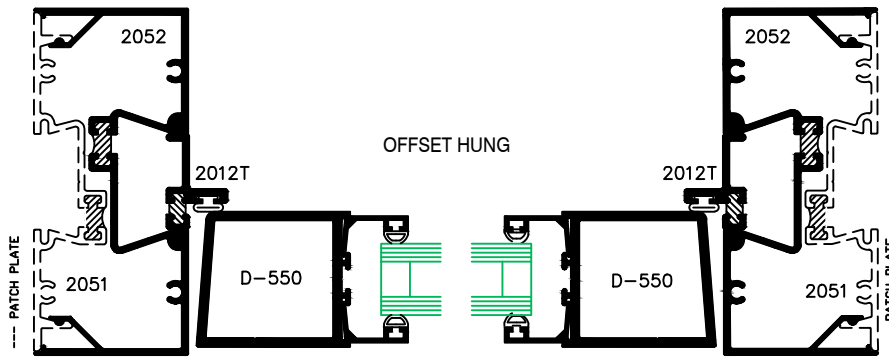
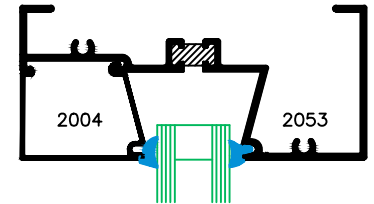
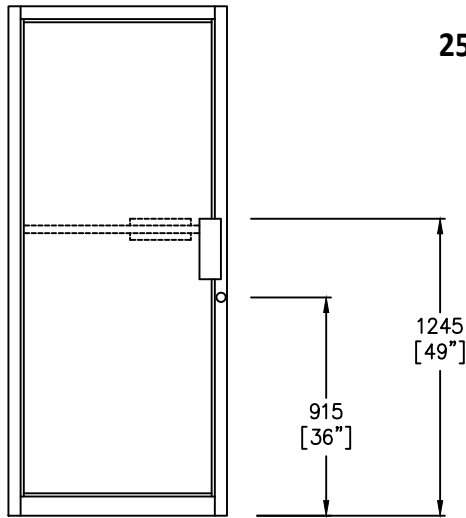

VARIOUS THRESHOLD OPTIONS
ARE AVAILABLE

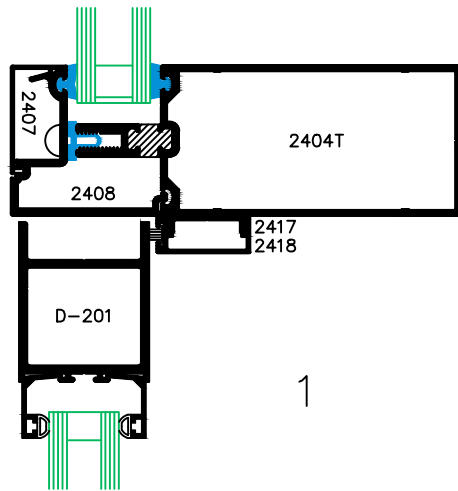

1

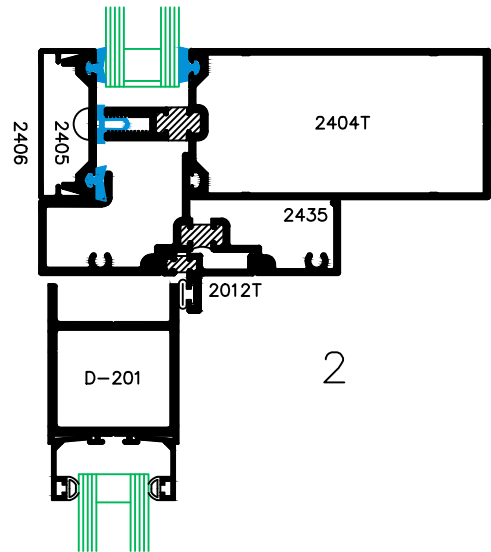

2

DETAILS 2400T FRAMING

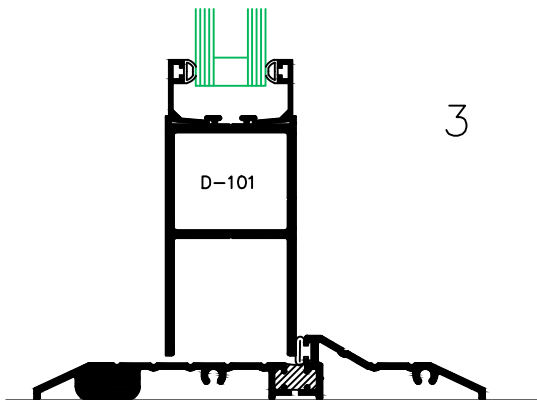

3

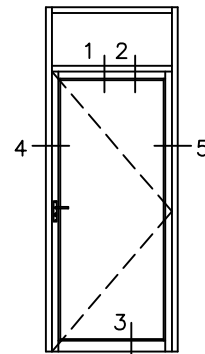

ELEVATION

VARIOUS THRESHOLD OPTIONS
ARE AVAILABLE

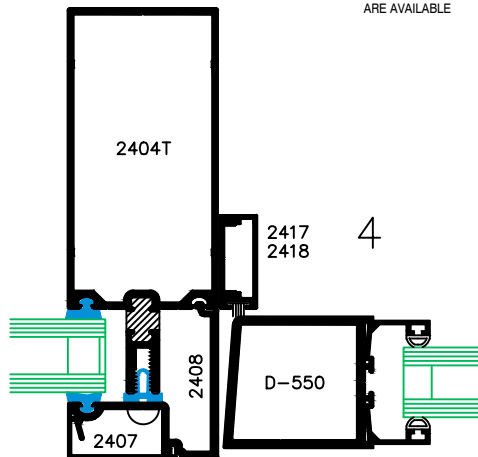

4

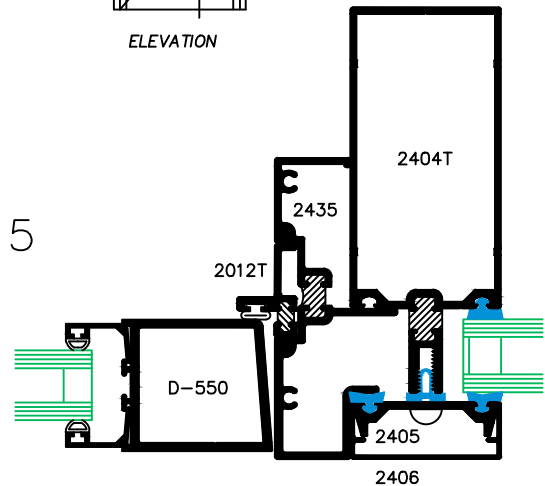

5



The 250T Thermally Broken Narrow Stile Door is an enhanced version of our popular 250 Narrow Stile Door, offering superior thermal performance and energy efficiency. Key features include:

- **Thermally Broken/Insulated Rails and Stiles:** Ensuring optimal thermal insulation and reducing energy loss.
- **Sealed Unit Glazing:** Providing enhanced weather resistance and improved insulation.
- **Compatibility with Metro Thermally Broken Framing:** Seamlessly integrates with Metro's thermally broken framing systems for a cohesive and efficient installation.
- **Mid and Bottom Rails:** Available in various sizes to meet your specific design and functionality requirements. (see page A-08a for details)
- **Welded Corners:** Each corner is welded & bolted for enhanced structural integrity.

Standard hardware includes: (see pages A-13 - A-13F)

- Offset Pivots
- Construction Security Lock (Exterior)
- Thumb Turn (Interior)
- Metro Standard Push Bar/Pull Handle
- ½ Inch Threshold
- Exposed Closer

Works with hinging hardware options, including:

- Continuous Hinges
- Butt Hinges
- Center Hung / Walking Beam Pivots

Compatible with most hardware options, including:

- Concealed Closer's
- Apartment Packages (Lever / Paddle)
- Offset D-Pulls and Ladder Pulls

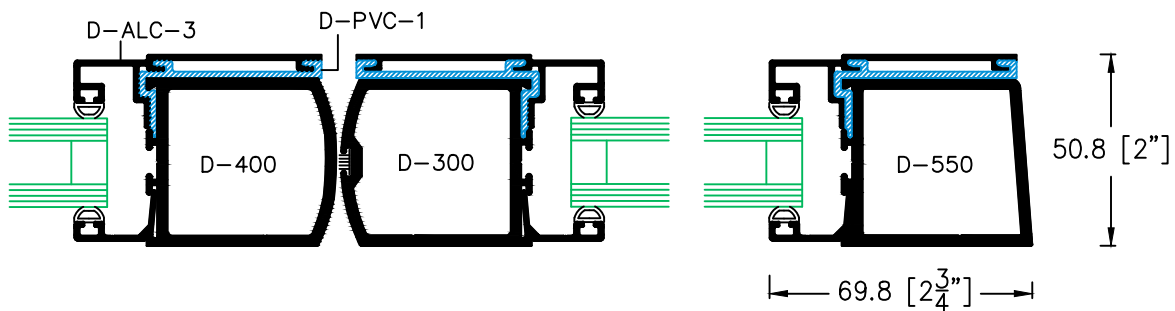
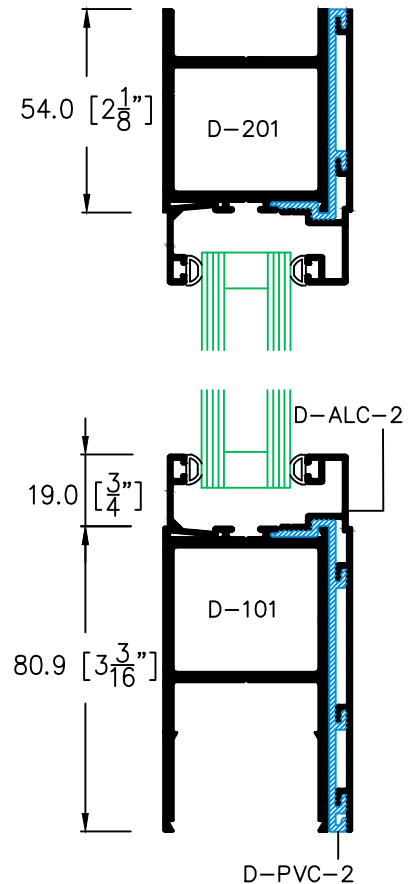
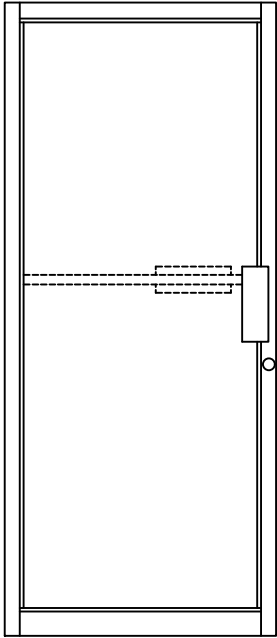

MEETING STILES

250T SERIES DOOR - 2050 SERIES FRAMING

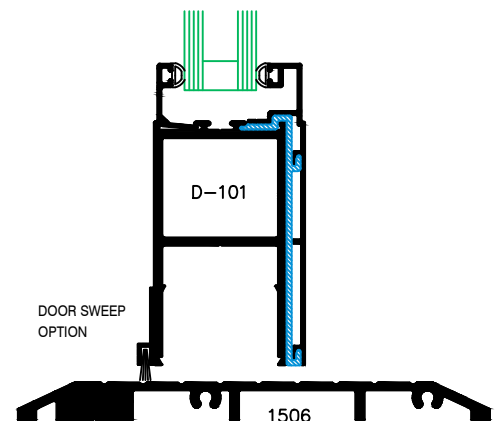
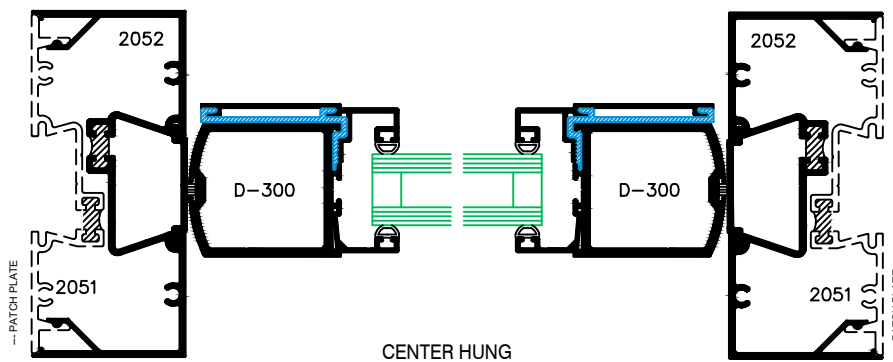
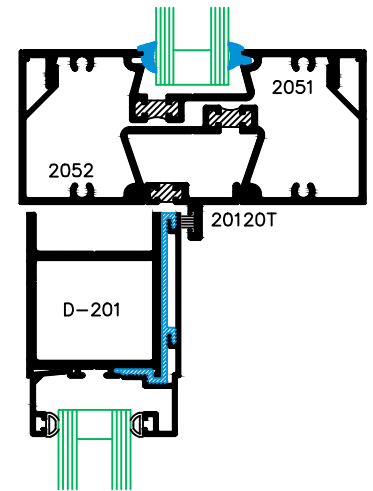
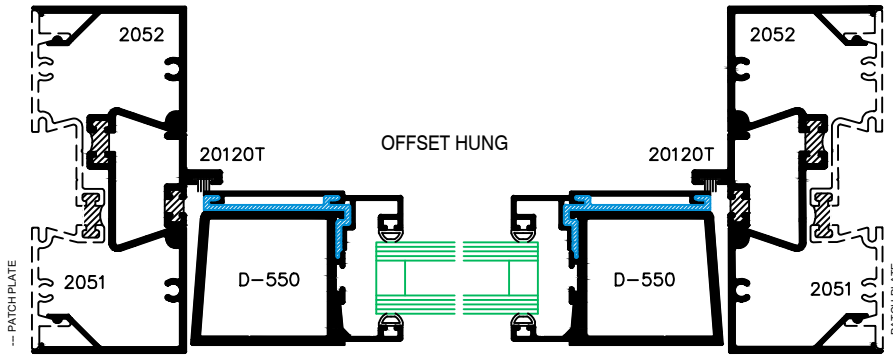
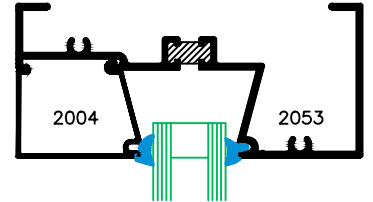
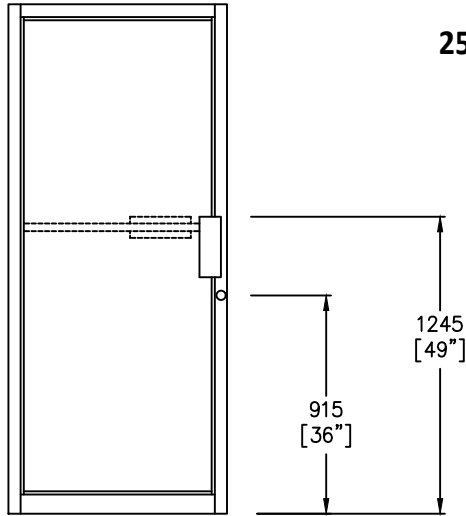

VARIOUS THRESHOLD OPTIONS ARE AVAILABLE

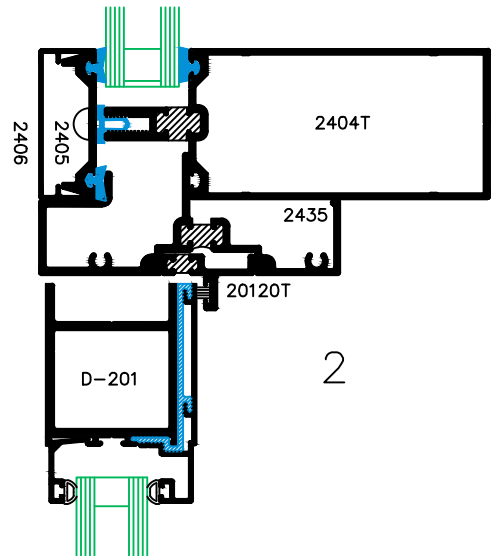
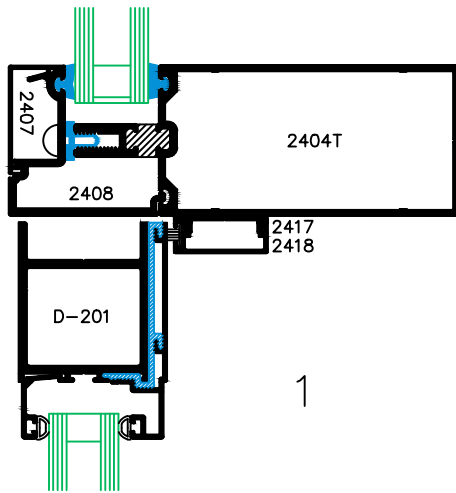

**DETAILS
2400T FRAMING**

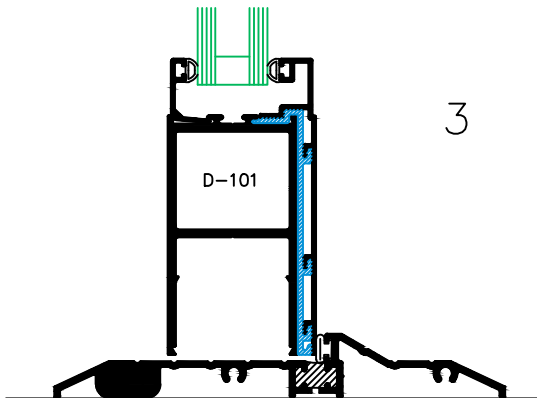

VARIOUS THRESHOLD OPTIONS
ARE AVAILABLE

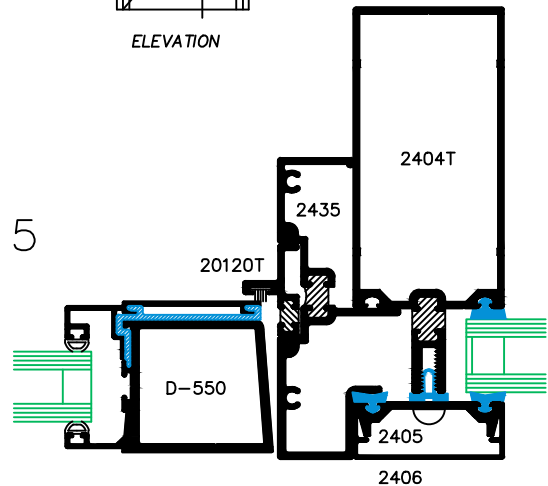
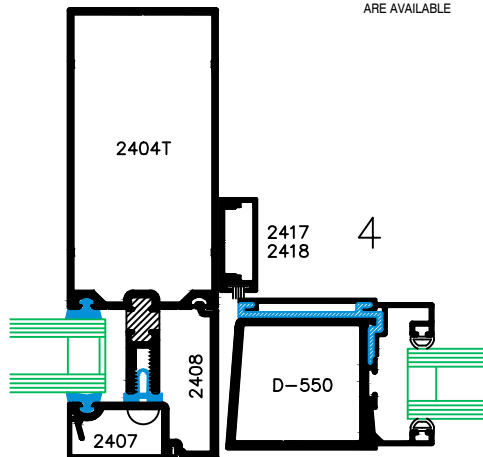
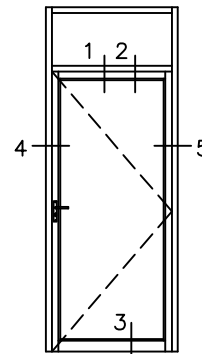



The 350 Medium Stile Door, designed for high-traffic areas, offers enhanced strength and durability, making it ideal for demanding commercial environments where robust performance and aesthetic appeal are essential.

- **Medium Stile Design:** Provides a sturdy and substantial appearance, suitable for high-use applications.
- **Single and Double Glazed Stops:** Accommodates different glazing configurations for enhanced performance and design flexibility.
- **Heavier Duty Construction:** Ensures long-lasting performance in high-traffic areas.
- **Compatibility with Metro Framing:** Seamlessly integrates with Metro framing systems for a cohesive installation.
- **Mid and Bottom Rails:** Available in various sizes to meet your specific design and functionality requirements. (see page A-08 for details)
- **Welded Corners:** Each corner is welded & bolted for enhanced structural integrity.

Standard hardware includes: (see pages A-13 - A-13F)

- Offset Pivots
- Construction Security Lock (Exterior)
- Thumb Turn (Interior)
- Metro Standard Push Bar/Pull Handle
- ½ Inch Threshold
- Exposed Closer

Works with hinging hardware options, including:

- Continuous Hinges
- Butt Hinges
- Center Hung / Walking Beam Pivots

Compatible with most hardware options, including:

- Concealed Closer's
- Apartment Packages (Lever / Paddle)
- Offset D-Pulls and Ladder Pulls

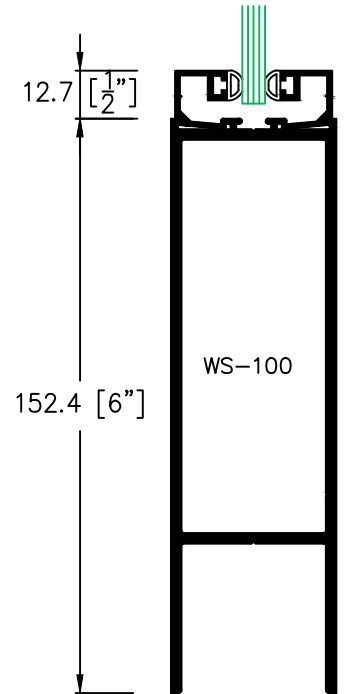
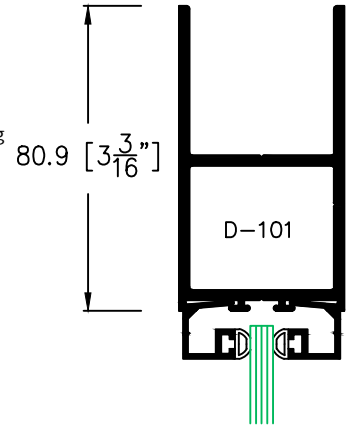
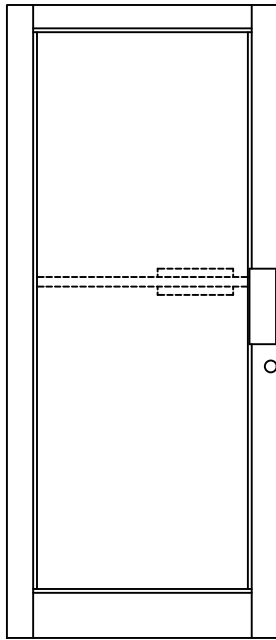

SINGLE GLAZED

DOUBLE GLAZED

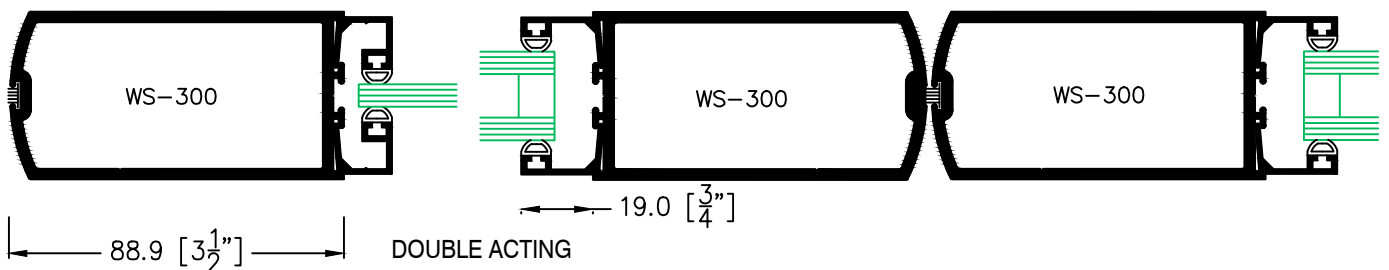
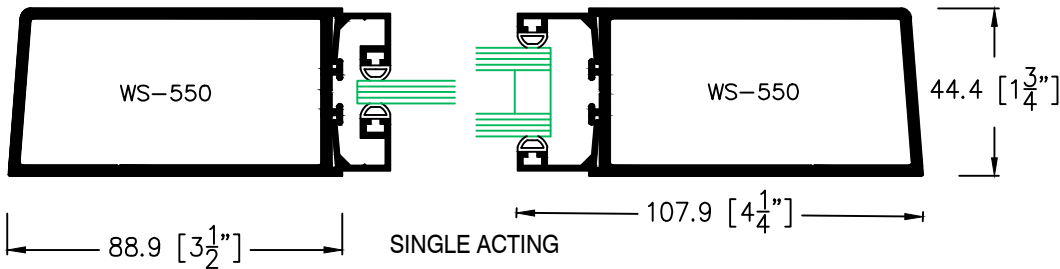

350 SERIES DOOR - 1750 SERIES FRAMING

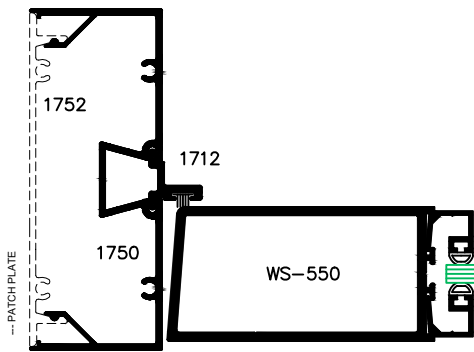
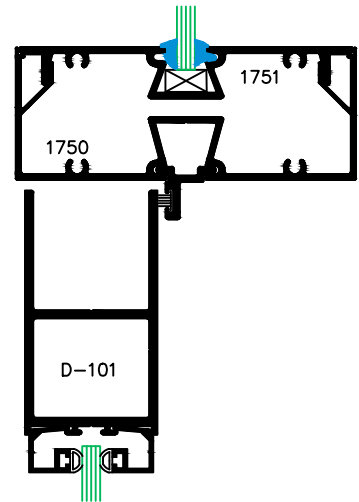
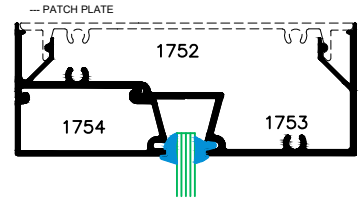
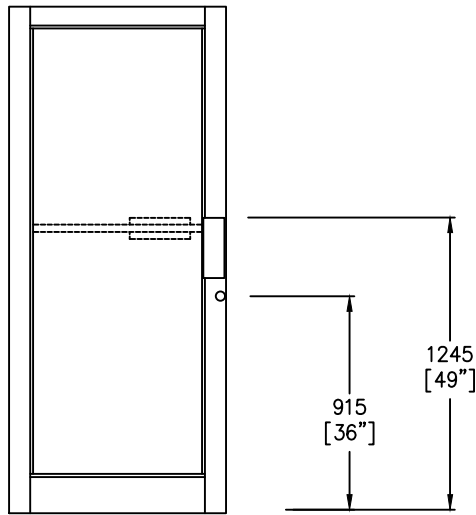

OFFSET HUNG

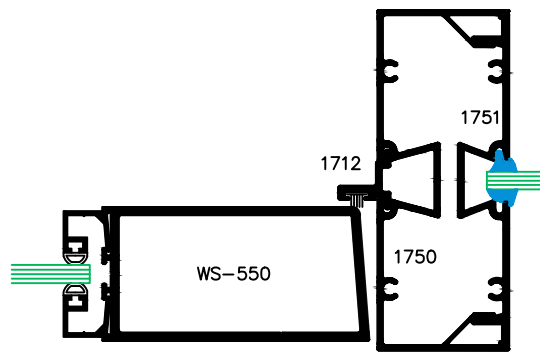

CENTER HUNG

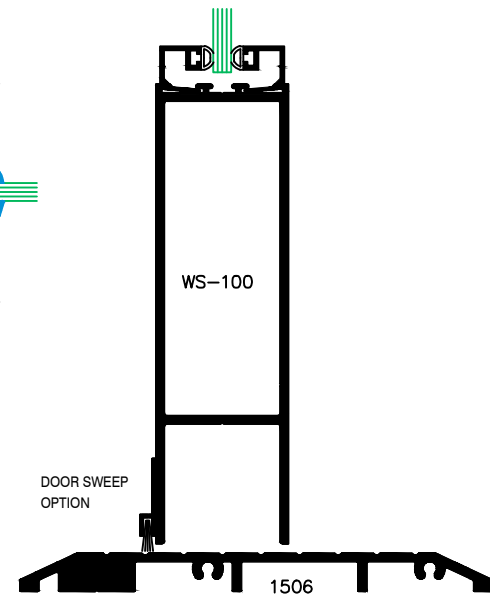
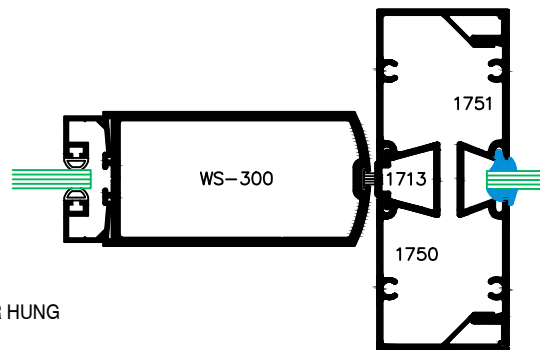
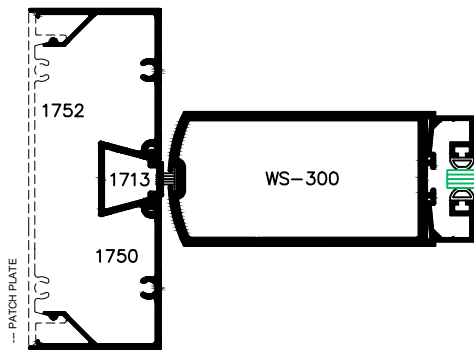

VARIOUS THRESHOLD OPTIONS
ARE AVAILABLE

350 SERIES DOOR - 2050 SERIES FRAMING

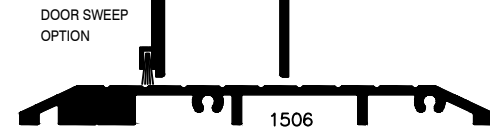
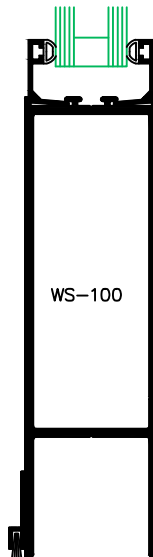
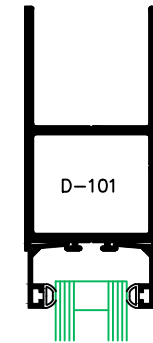
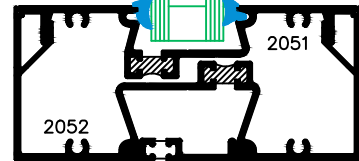
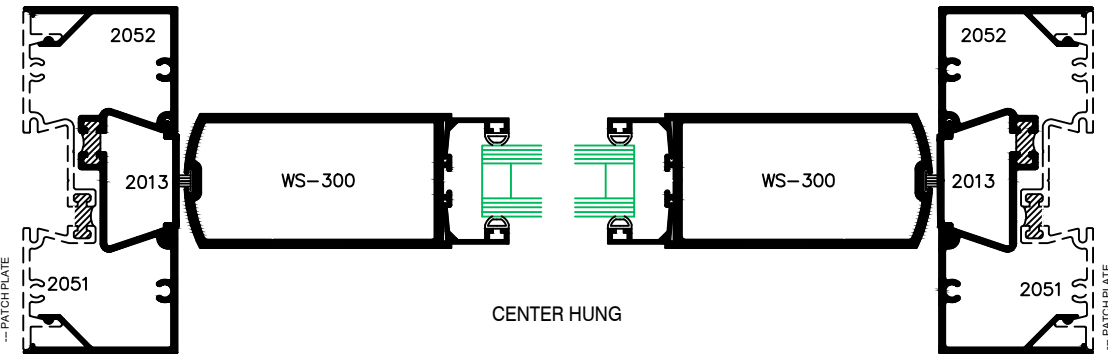
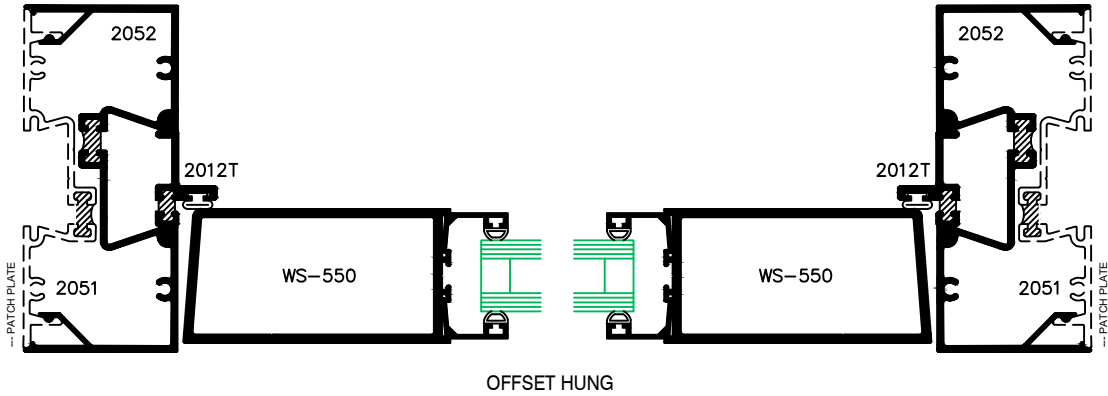
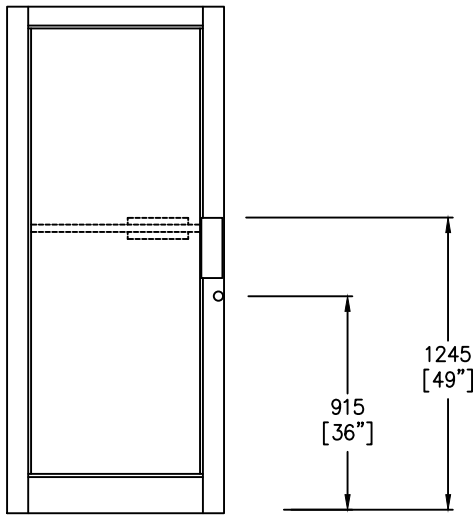

VARIOUS THRESHOLD OPTIONS
ARE AVAILABLE

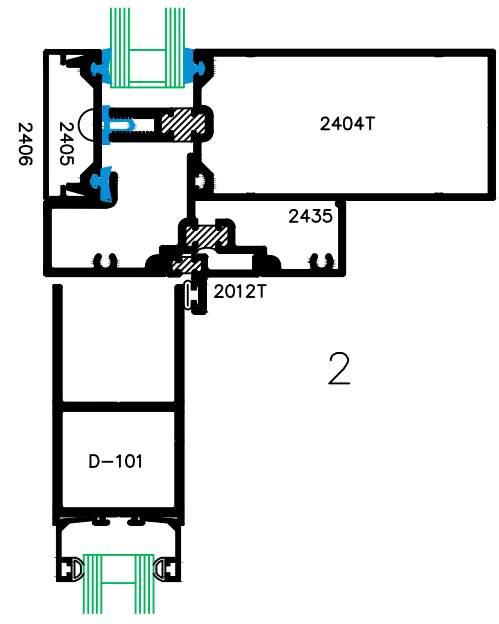
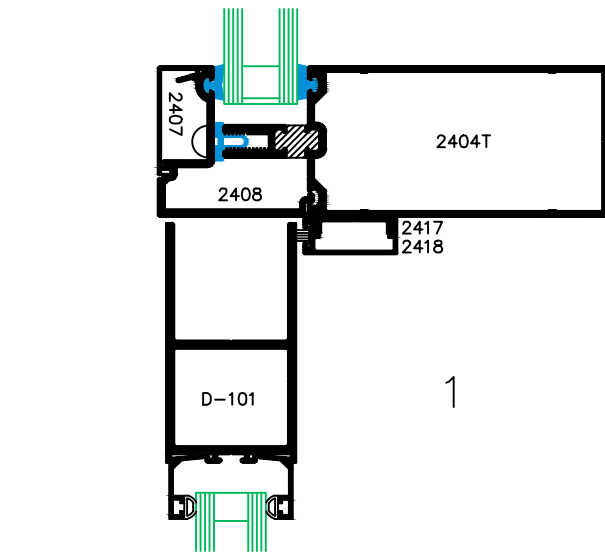

**DETAILS
2400T FRAMING**

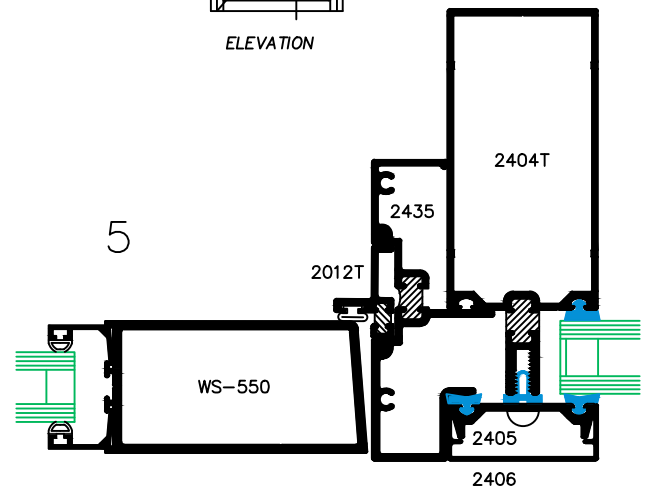
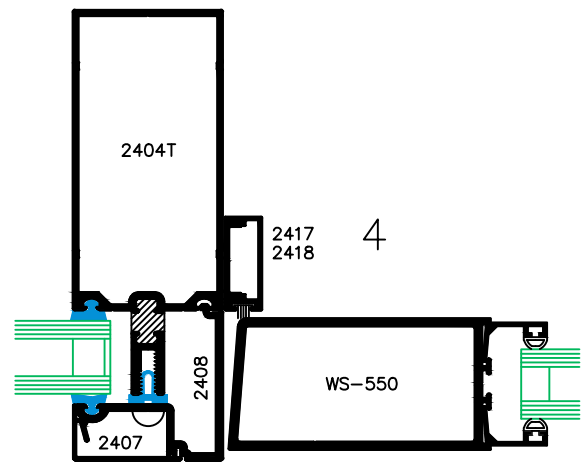
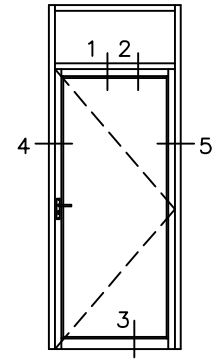
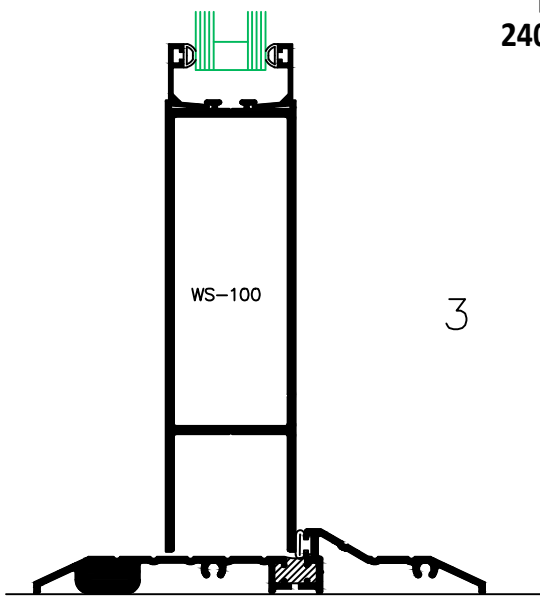



**METRO
ALUMINUM**
Products Ltd.

350T SERIES

THERMALLY BROKEN
MEDIUM STILE DOOR

A



The 350T Thermally Broken Medium Stile Door offers superior thermal performance and energy efficiency, designed for high-traffic areas that require extra strength and durability. Key features include:

- **Thermally Broken/Insulated Rails and Stiles:** Ensuring optimal thermal insulation and reducing energy loss.
- **Sealed Unit Glazing:** Providing enhanced weather resistance and improved insulation.
- **Medium Stile Design:** A robust and substantial appearance, suitable for high-use applications.
- **Heavier Duty Construction:** Ensures long-lasting performance in high-traffic areas.
- **Compatibility with Metro Thermally Broken Framing:** Seamlessly integrates with Metro framing systems for a cohesive installation.
- **Mid and Bottom Rails:** Available in various sizes to meet your specific design and functionality requirements. (see page A-08a for details)
- **Welded Corners:** Each corner is welded & bolted for enhanced structural integrity.

Standard hardware includes: (see pages A-13 - A-13F)

- Offset Pivots
- Construction Security Lock (Exterior)
- Thumb Turn (Interior)
- Metro Standard Push Bar/Pull Handle
- ½ Inch Threshold
- Exposed Closer

Works with hinging hardware options, including:

- Continuous Hinges
- Butt Hinges
- Center Hung / Walking Beam Pivots

Compatible with most hardware options, including:

- Concealed Closer's
- Apartment Packages (Lever / Paddle)
- Offset D-Pulls and Ladder Pulls

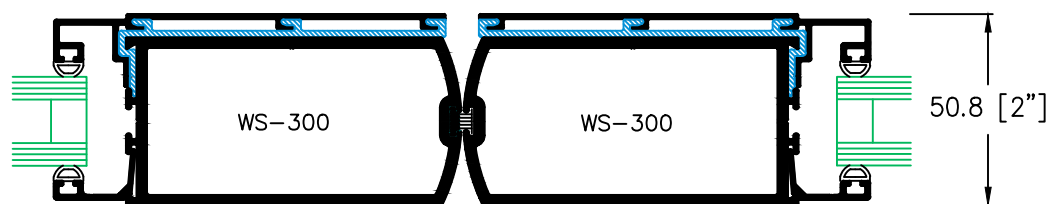
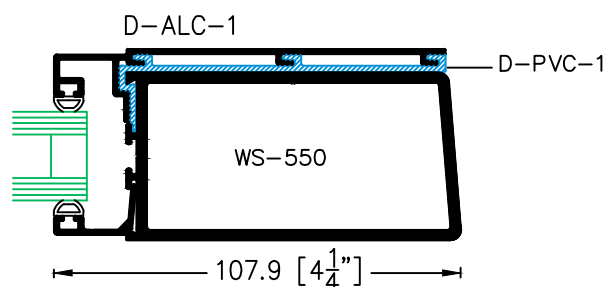
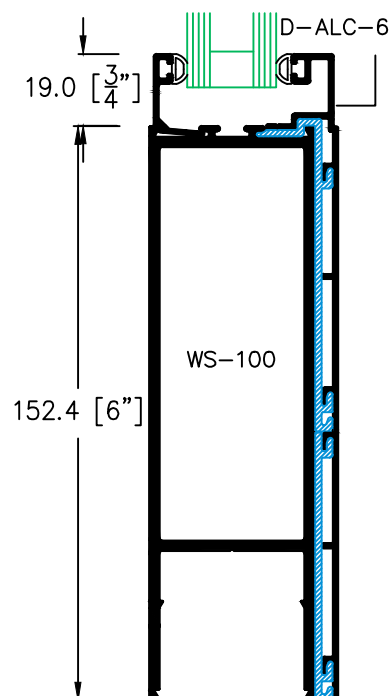
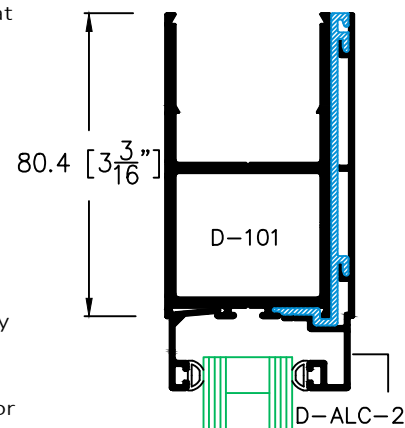
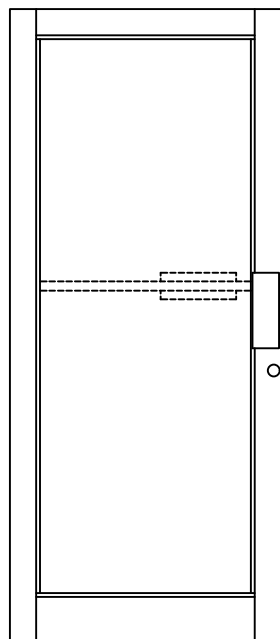

MEETING STILES

350T SERIES DOOR - 2050 SERIES FRAMING

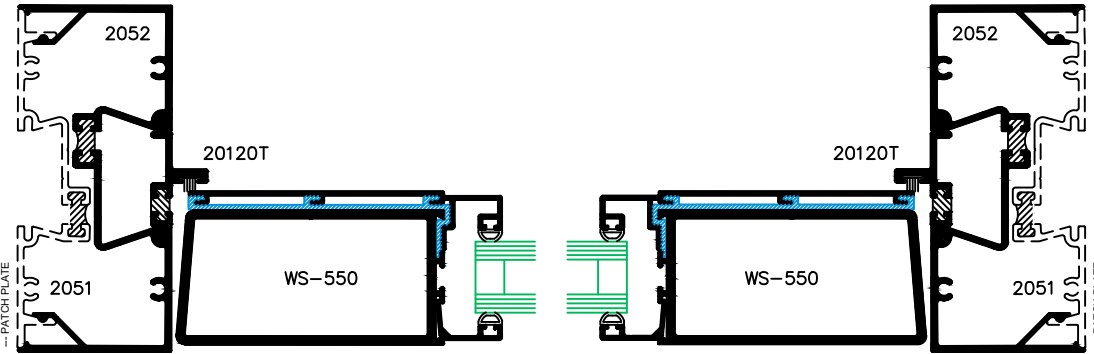
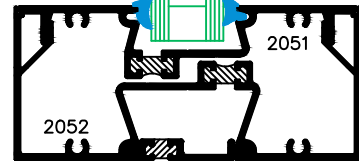
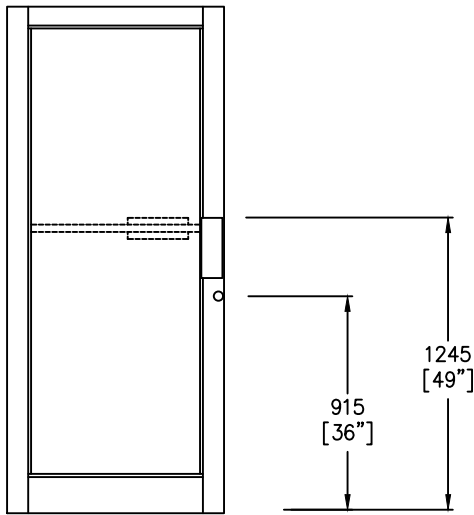

OFFSET HUNG

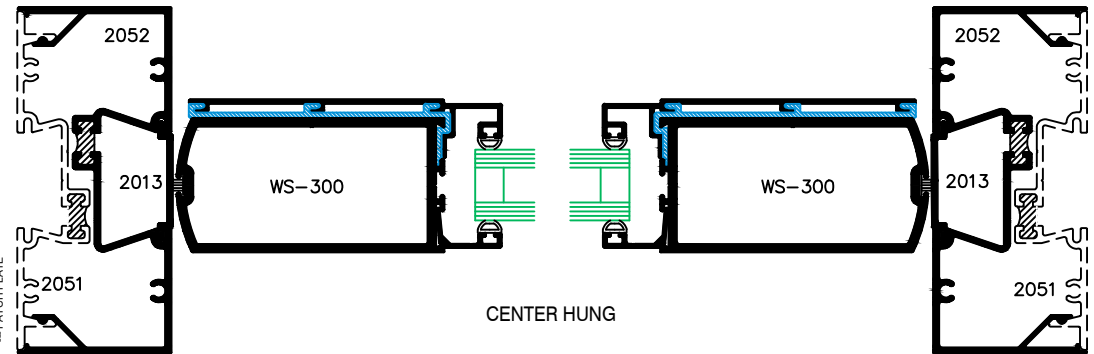
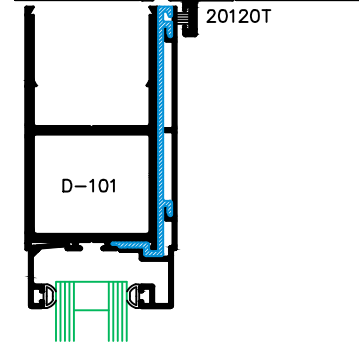

CENTER HUNG

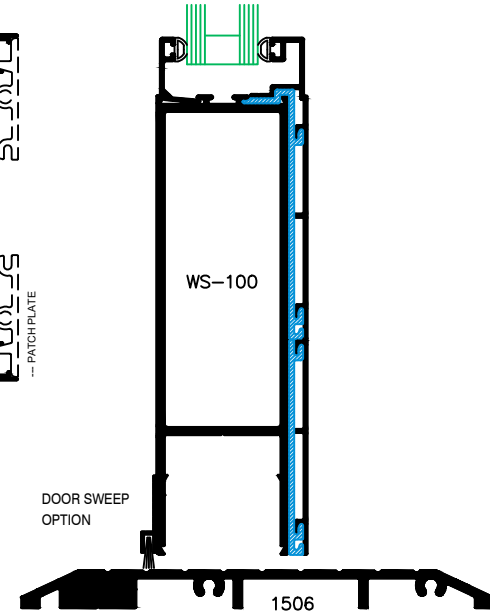

VARIOUS THRESHOLD OPTIONS
ARE AVAILABLE

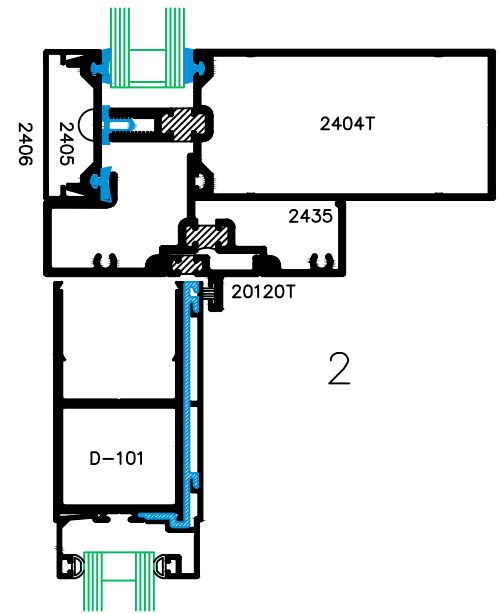
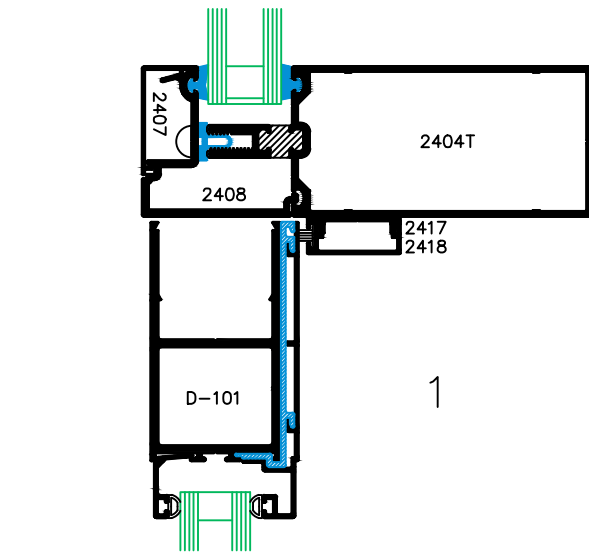

DETAILS
2400T FRAMING

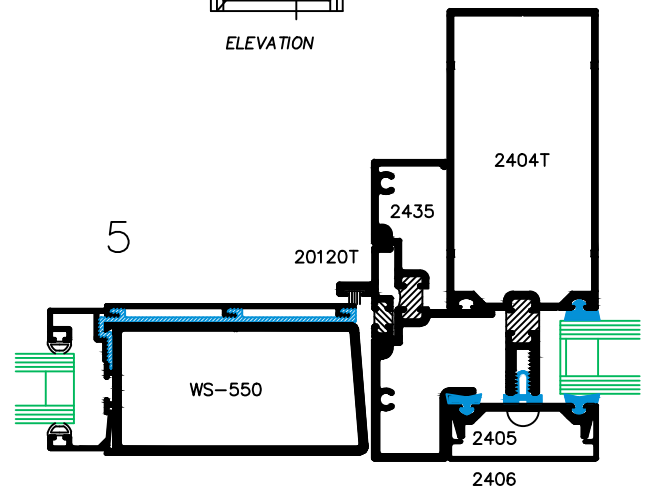
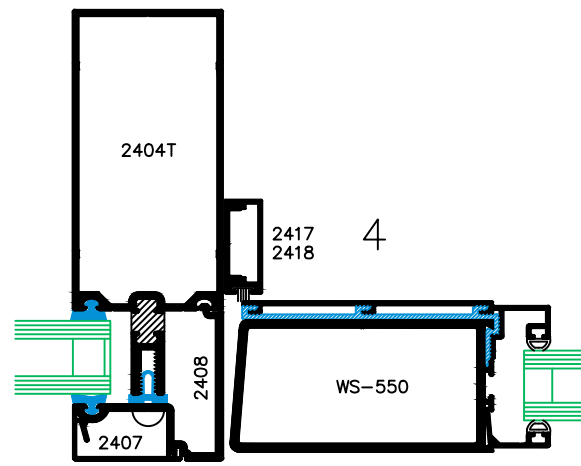
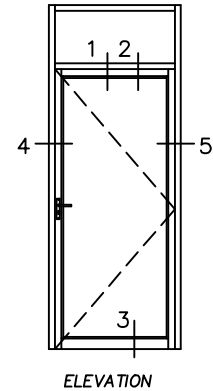
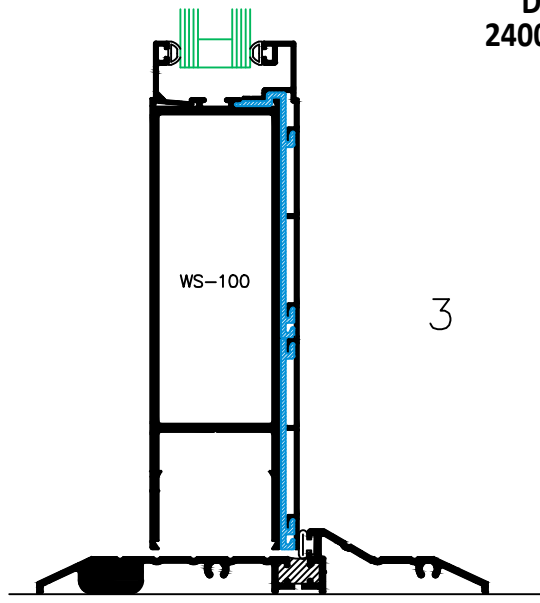



The 500 Series Wide Stile Door offers a truly monumental appearance with enhanced strength and durability, combining grandeur with functionality, making it ideal for prestigious commercial and institutional settings that demand both aesthetic appeal and robust performance. Key features include:

- **Wide Stile Design:** Provides a substantial and impressive aesthetic suitable for architectural statement pieces.
- **Single and Double Glazed Stops:** Accommodates different glazing configurations for enhanced performance and design flexibility.
- **Heavier Duty Construction:** Built for durability and longevity, ensuring reliable performance and high-traffic areas.
- **Compatibility with Metro Framing:** Seamlessly integrates with Metro framing systems for a cohesive installation.
- **Mid and Bottom Rails:** Available in various sizes to meet your specific design and functionality requirements. (see page A-08 for details)
- **Welded Corners:** Each corner is welded & bolted for enhanced structural integrity.

Standard hardware includes: (see pages A-13 - A-13F)

- Offset Pivots
- Construction Security Lock (Exterior)
- Thumb Turn (Interior)
- Metro Standard Push Bar/Pull Handle
- ½ Inch Threshold
- Exposed Closer

Works with hinging hardware options, including:

- Continuous Hinges
- Butt Hinges
- Center Hung / Walking Beam Pivots

Compatible with most hardware options, including:

- Concealed Closer's
- Apartment Packages (Lever / Paddle)
- Offset D-Pulls and Ladder Pulls

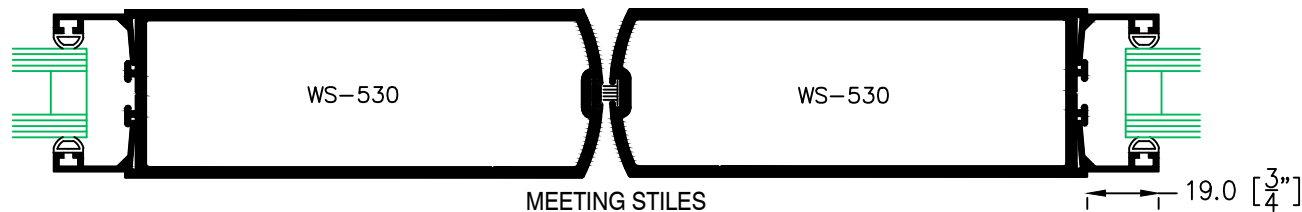
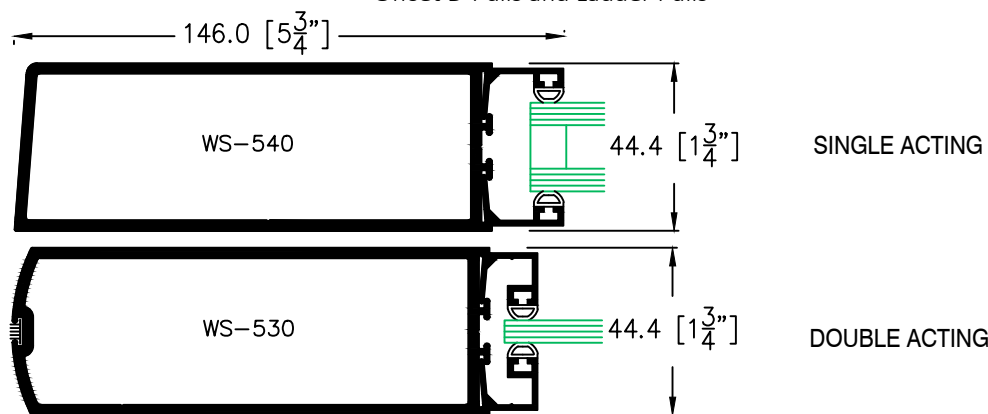
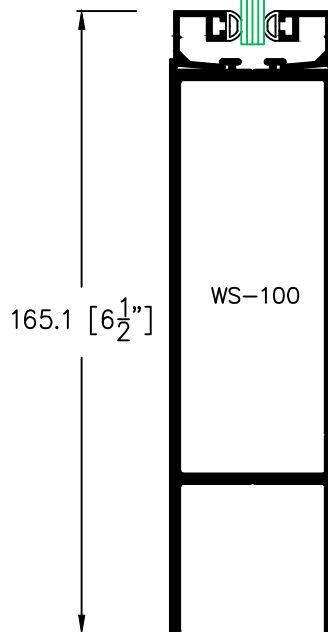
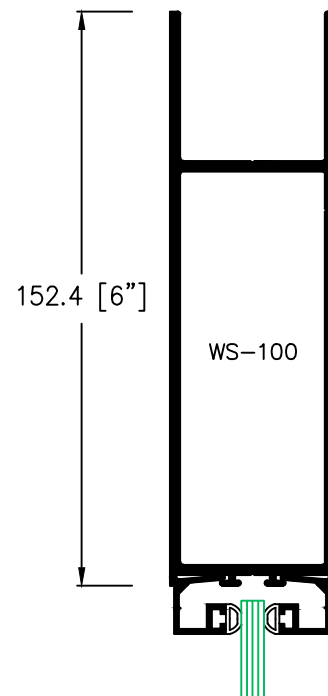
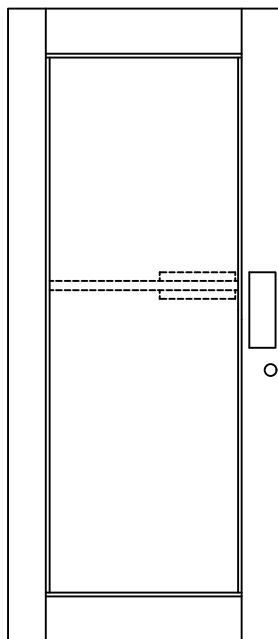

500 SERIES DOOR - 1750 SERIES FRAMING

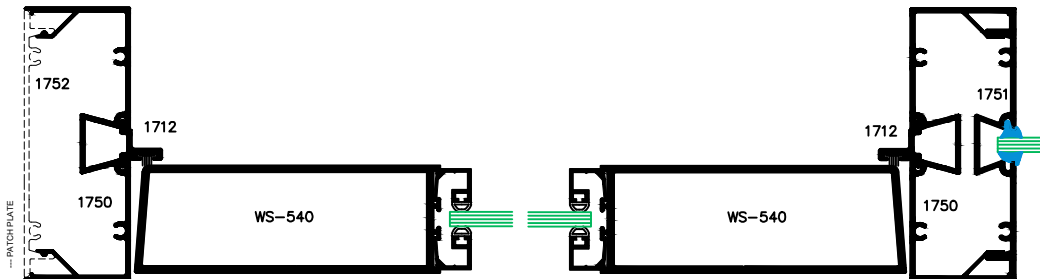
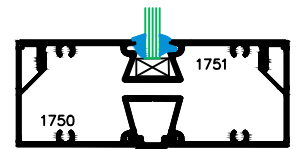
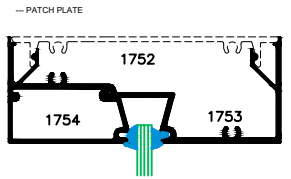
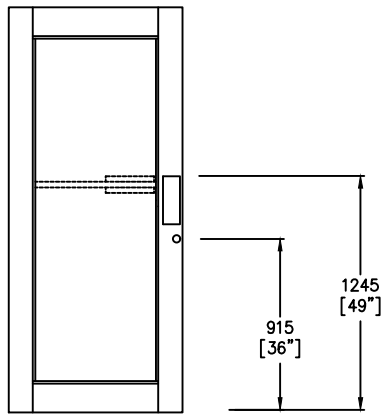

OFFSET HUNG

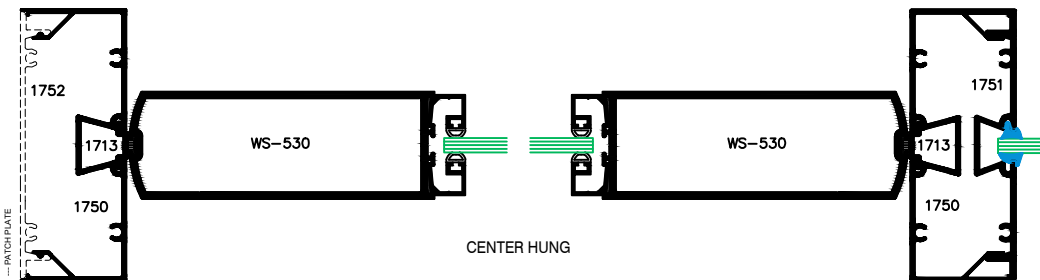

CENTER HUNG

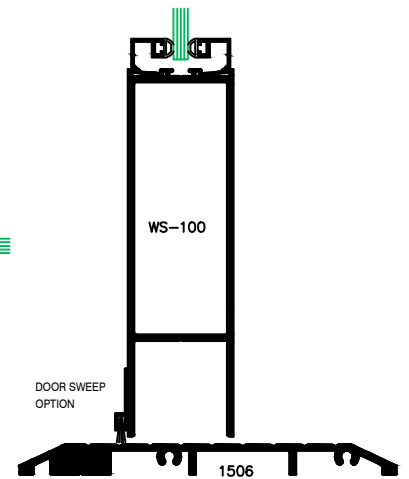

VARIOUS THRESHOLD OPTIONS
ARE AVAILABLE

500 SERIES DOOR - 2050 SERIES FRAMING

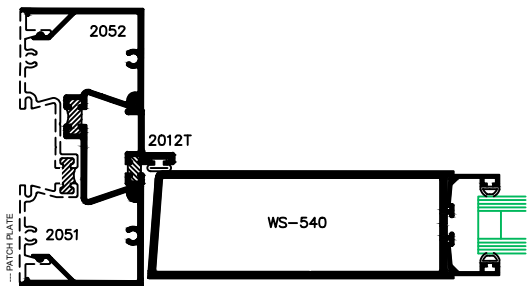
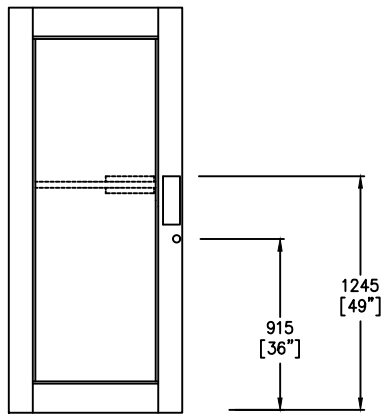

OFFSET HUNG

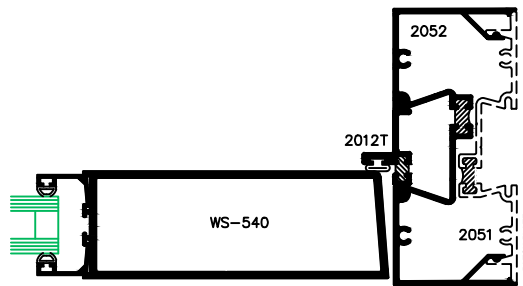

CENTER HUNG

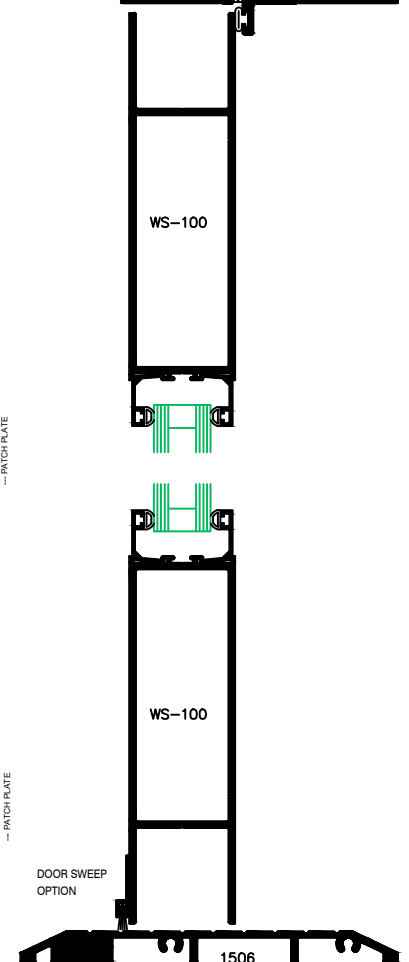
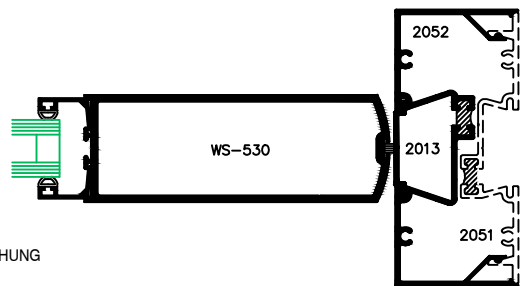
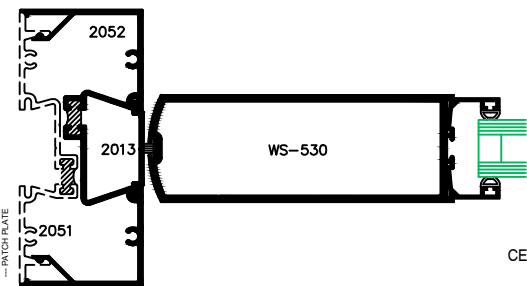

VARIOUS THRESHOLD OPTIONS ARE AVAILABLE

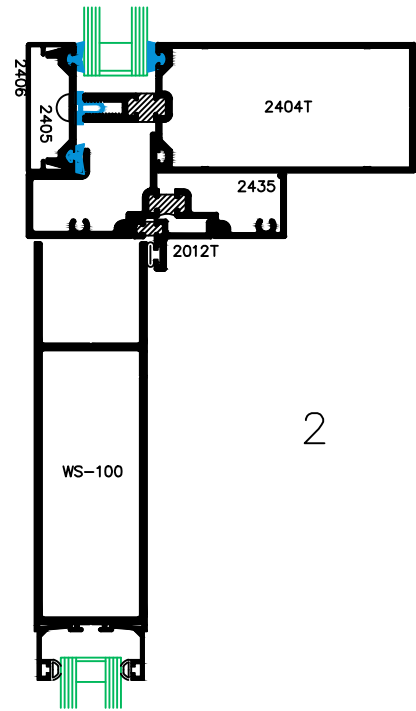
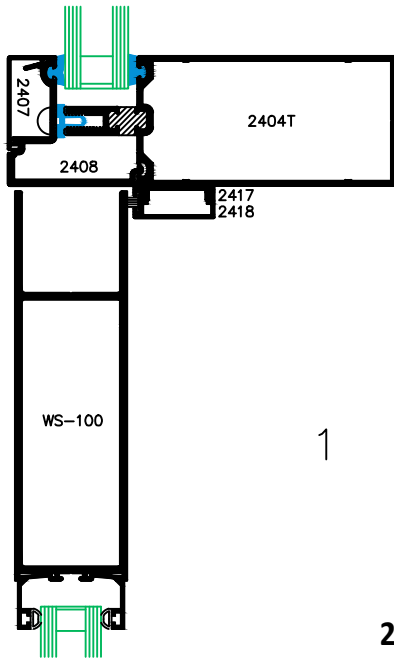

DETAILS
2400T FRAMING

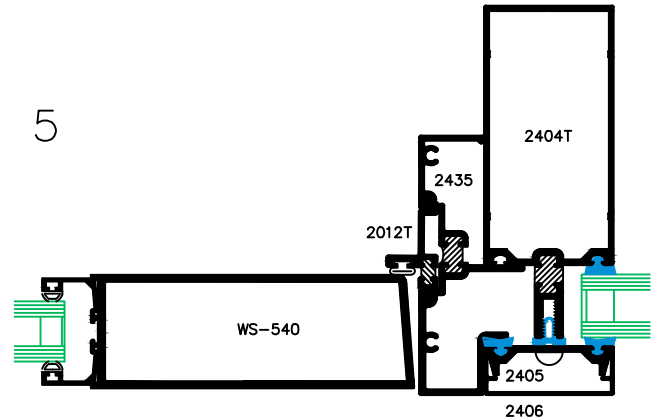
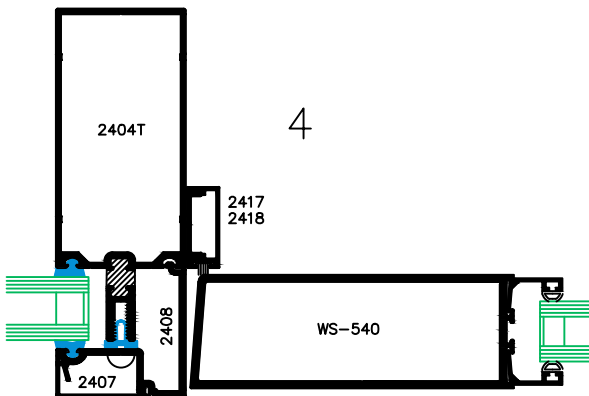
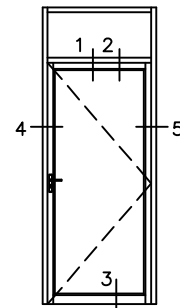
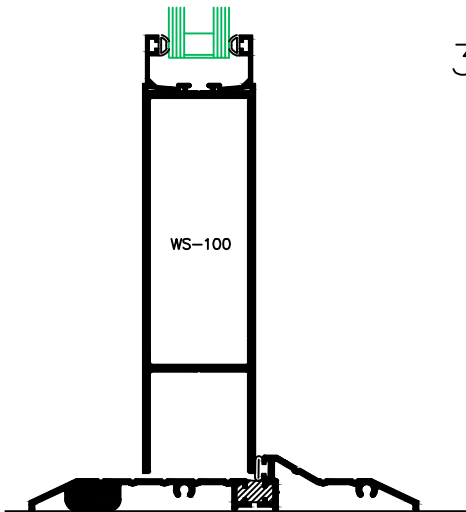



The 500T Series Thermally Broken Wide Stile Door combines a monumental appearance with superior thermal performance and durability, ideal for prestigious commercial and institutional settings. Key features include:

- **Thermally Broken/Insulated Rails and Stiles:** Ensures optimal thermal insulation, reducing energy loss and enhancing comfort.
- **Sealed Unit Glazing:** Providing enhanced weather resistance and improved insulation.
- **Heavier Duty Construction:** Built for durability and longevity, ensuring reliable performance and high-traffic areas.
- **Compatibility with Metro Thermally Broken Framing:** Seamlessly integrates with Metro framing systems for a cohesive installation.
- **Mid and Bottom Rails:** Available in various sizes to meet your specific design and functionality requirements. (see page A-08a for details)
- **Welded Corners:** Each corner is welded & bolted for enhanced structural integrity.

Standard hardware includes: (see pages A-13 - A-13F)

- Offset Pivots
- Construction Security Lock (Exterior)
- Thumb Turn (Interior)
- Metro Standard Push Bar/Pull Handle
- ½ Inch Threshold
- Exposed Closer

Works with hinging hardware options, including:

- Continuous Hinges
- Butt Hinges
- Center Hung / Walking Beam Pivots

Compatible with most hardware options, including:

- Concealed Closer's
- Apartment Packages (Lever / Paddle)
- Offset D-Pulls and Ladder Pulls

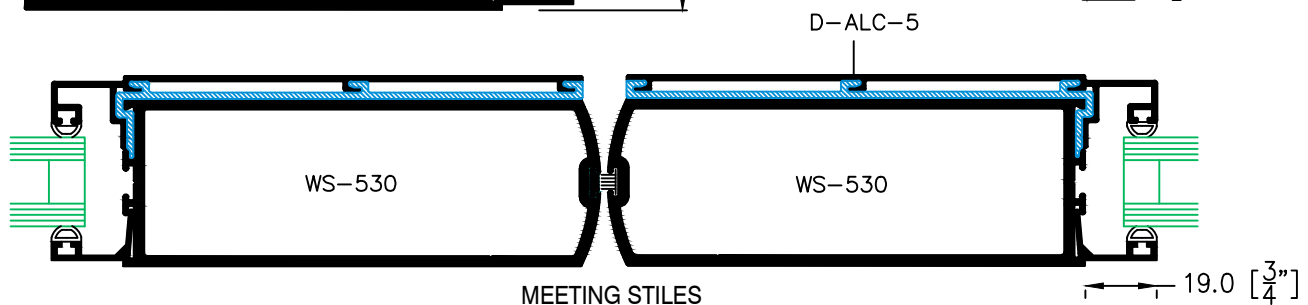
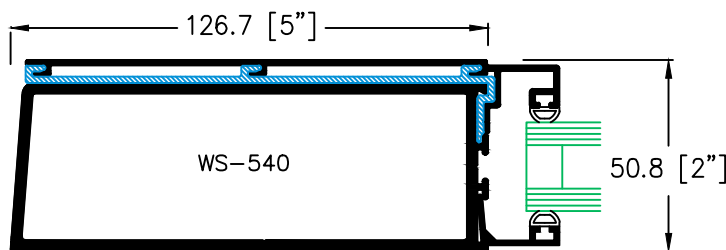
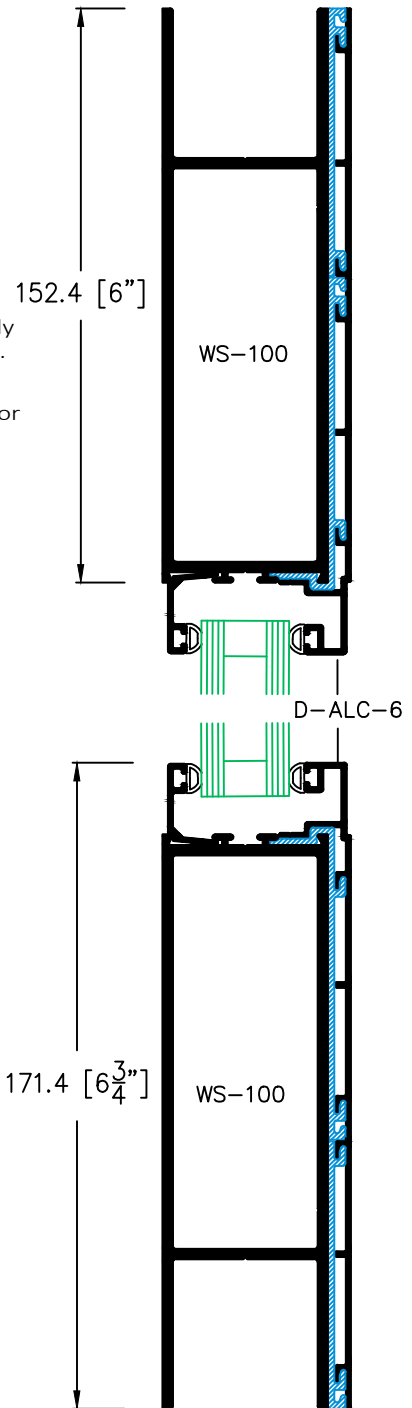
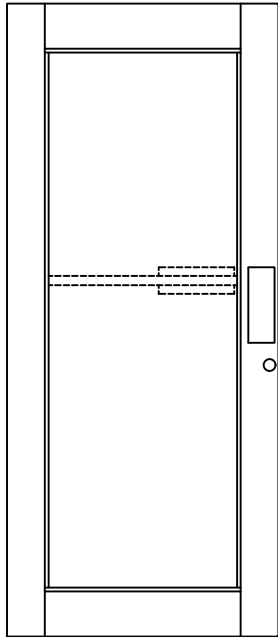

500T SERIES DOOR - 2050 SERIES FRAMING

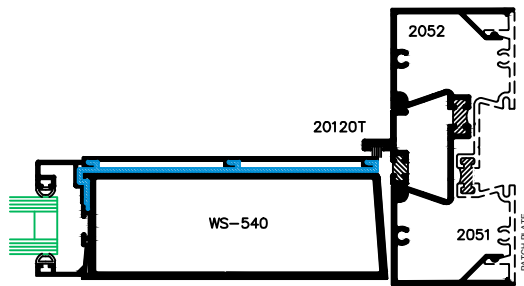
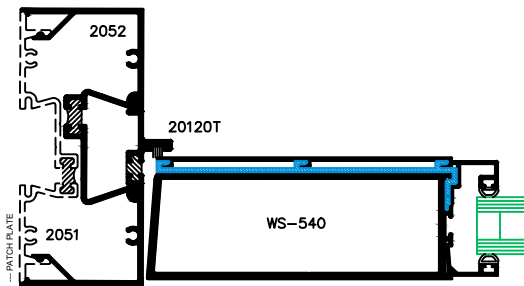
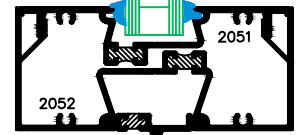
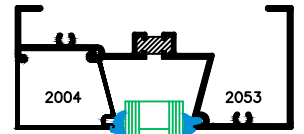
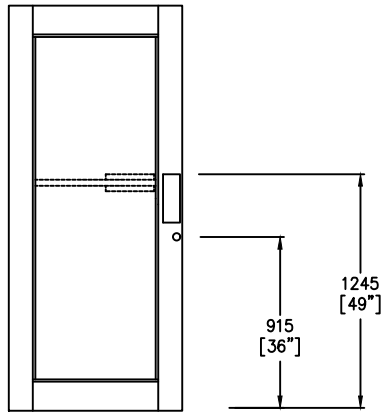

OFFSET HUNG

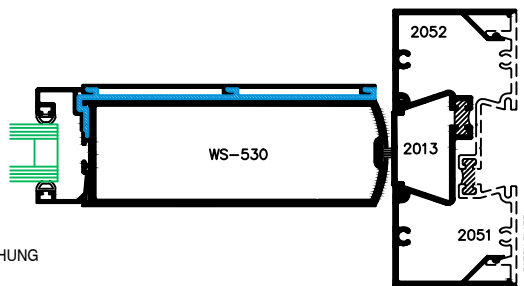
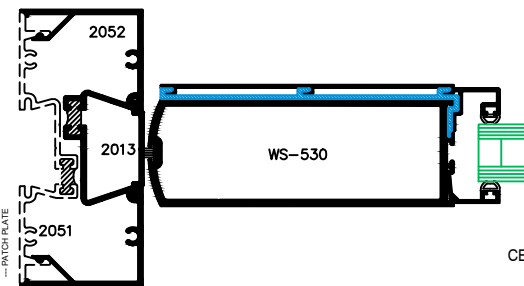

CENTER HUNG

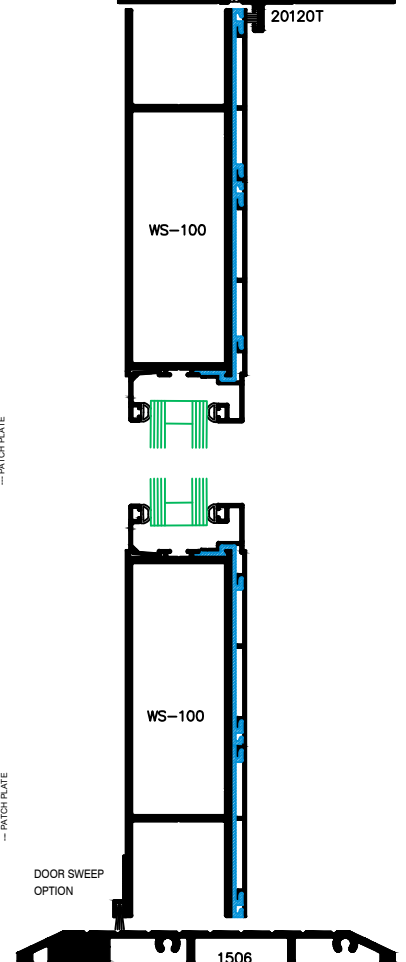

DOOR SWEEP
OPTION

VARIOUS THRESHOLD OPTIONS
ARE AVAILABLE

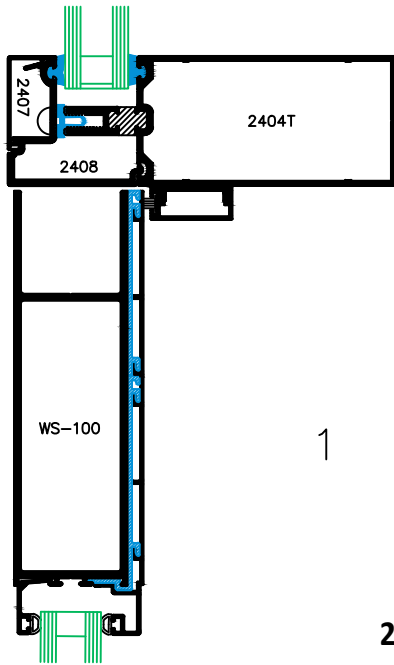

1

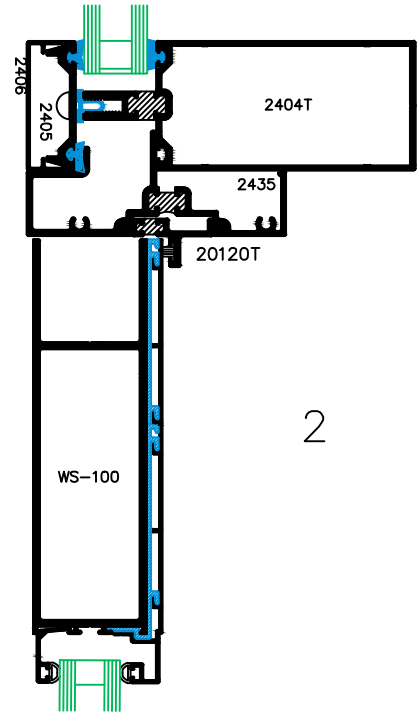

2

DETAILS
2400T FRAMING

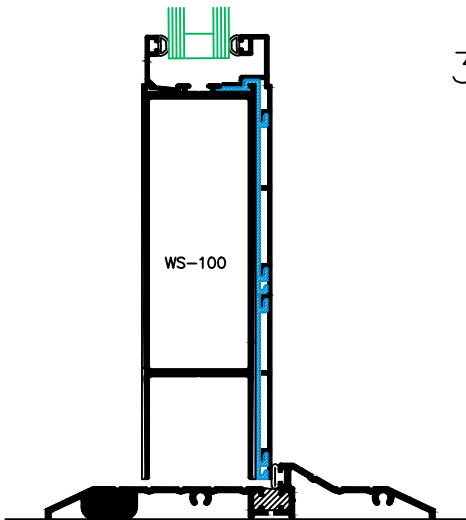

3

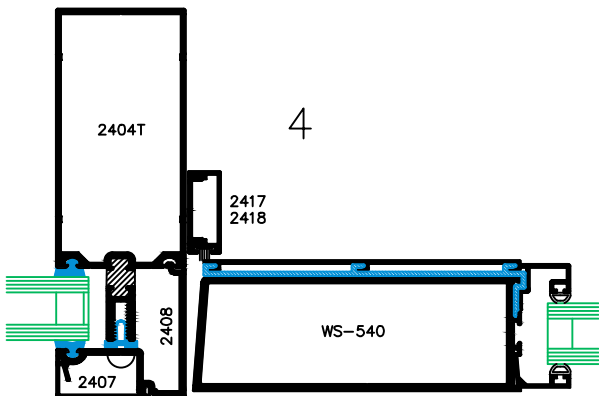
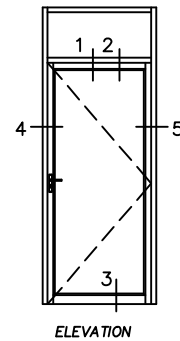

4

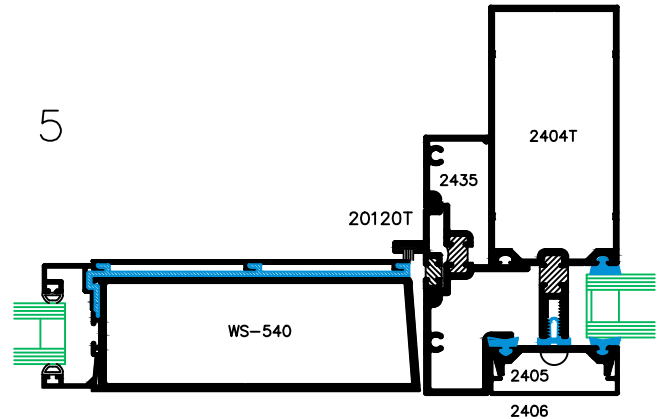

5

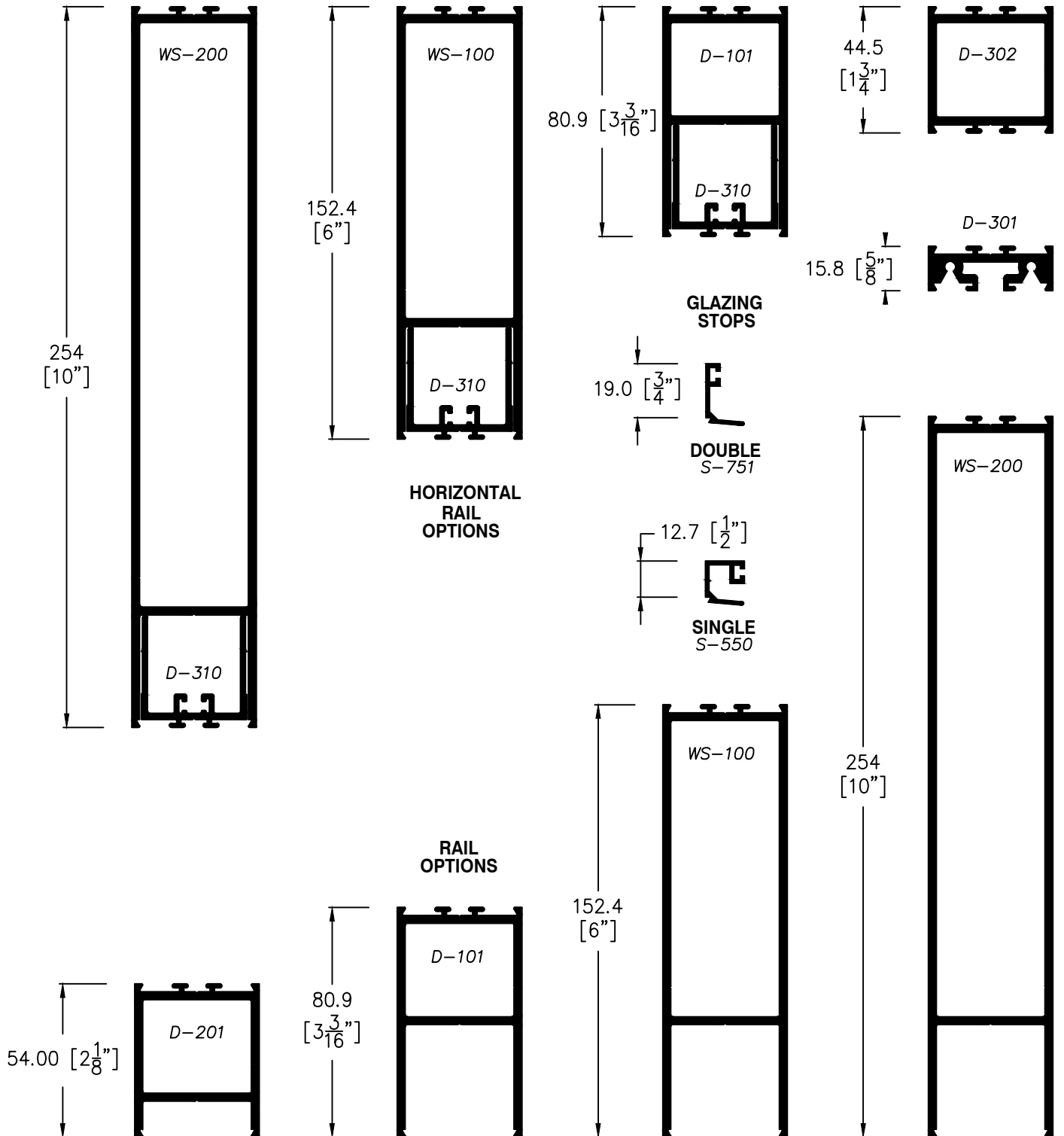

NOTE: CUSTOM RAILS ARE ALSO AVAILABLE



**METRO
ALUMINUM**
Products Ltd.

DOOR PARTS

THERMALLY BROKEN
2" CLADDED DOOR

**A
09A**

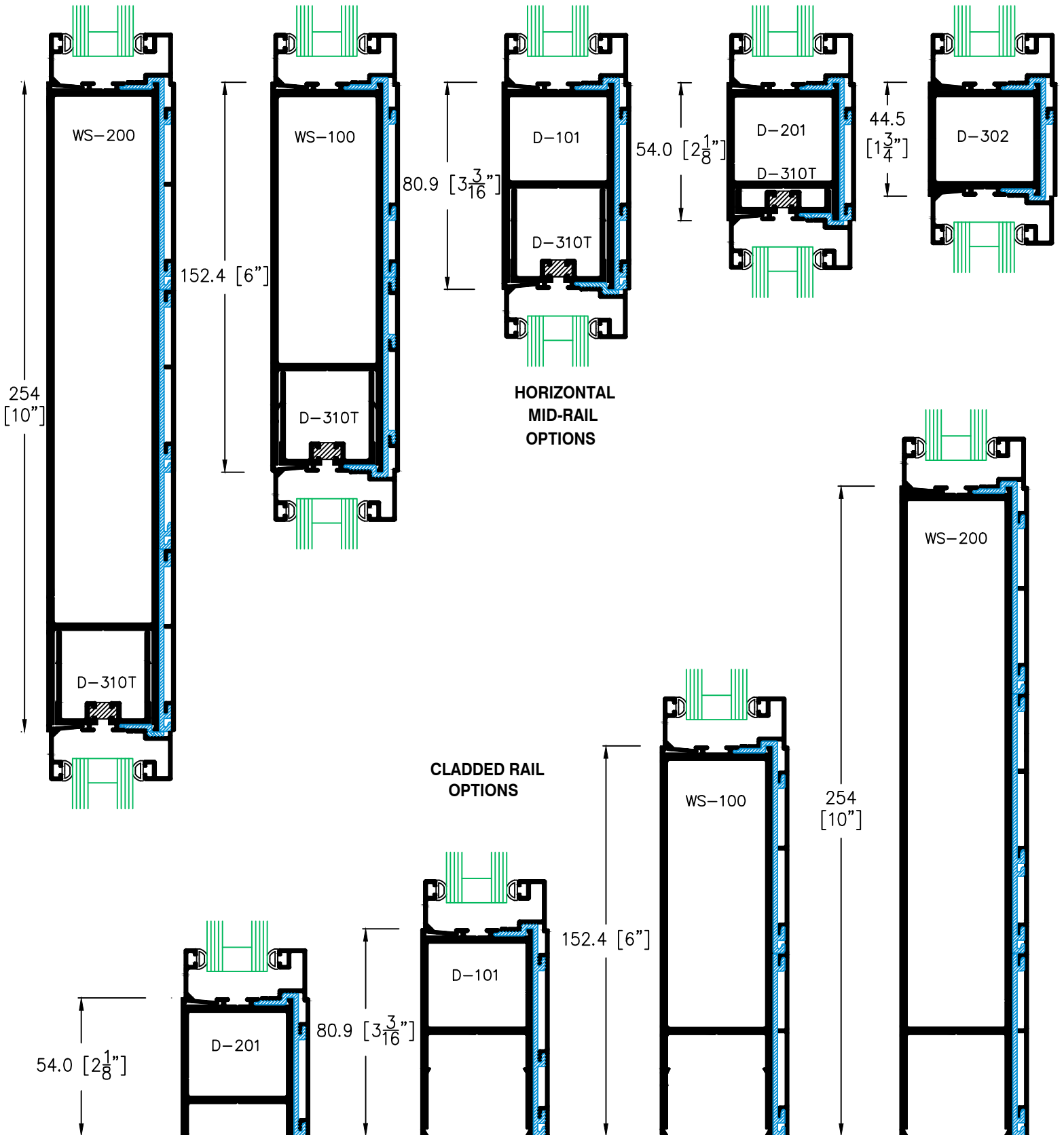



**METRO
ALUMINUM**
Products Ltd.

GLACIER 2000

RESIDENTIAL
THERMALLY BROKEN DOORS

A



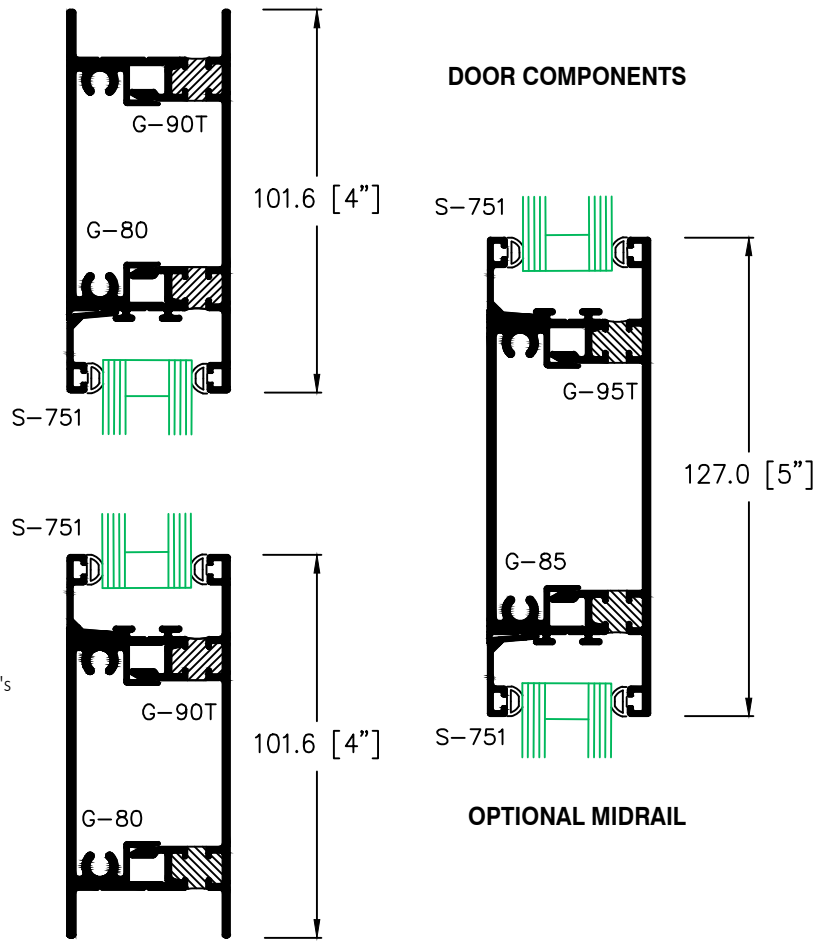
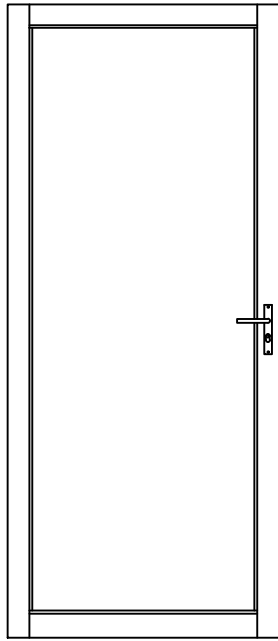

The Glacier 2000 Series Residential Door is designed for both new and replacement applications, offering superior energy savings and durability. Compatible with Metro's systems, this door combines aesthetic appeal, energy efficiency, and robust performance, making it the perfect choice for enhancing the comfort and design of any home or office setting. Key features include:

- **Energy Savings:** Durable double thermal break construction ensures excellent insulation and energy efficiency.
- **Sealed Glazing Units:** Provides enhanced weather resistance and improved insulation.
- **Color Options:** Available in standard anodized or custom painted colors, with split color options to match your unique style.
- **Size Options:** Available in standard or custom sizes to fit any application.
- **Mid-rail Option:** Adds design flexibility and functionality.
- **Exterior Key Cylinder:** Offers secure access from the outside.
- **Lever Handle:** Easy and comfortable operation.
- **Interior Thumb Turn:** Convenient interior locking mechanism.
- **Single and Pair Door Options:** Suitable for various residential or office needs and preferences.

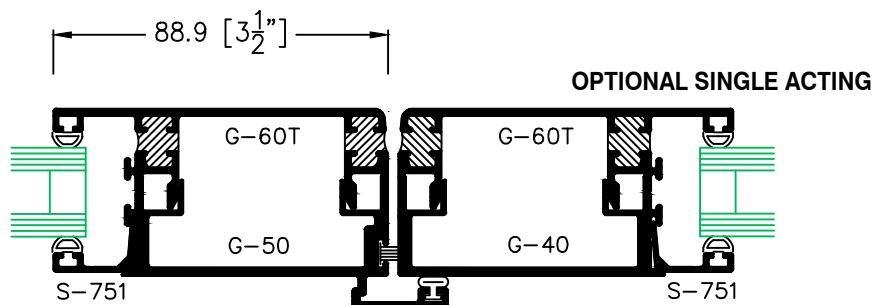
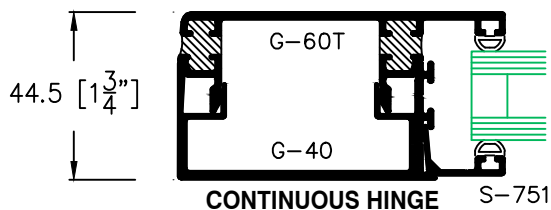
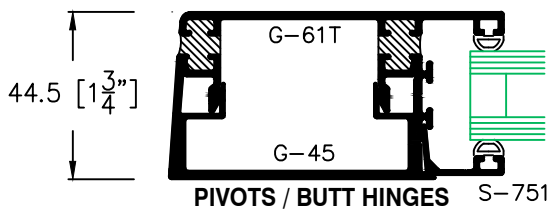
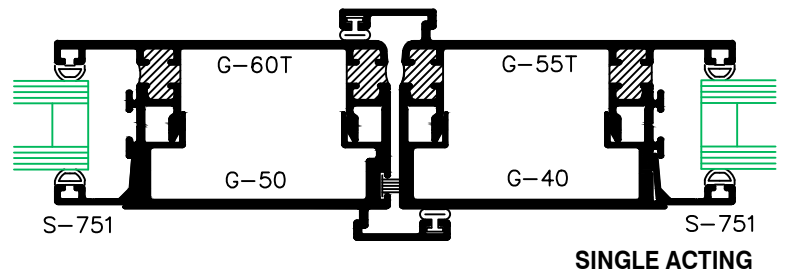



**METRO
ALUMINUM**
Products Ltd.

GLACIER 2000
RESIDENTIAL
THERMALLY BROKEN DOORS

**A
10A**

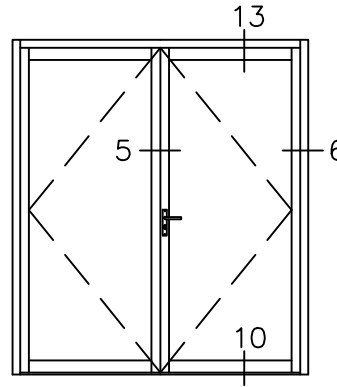
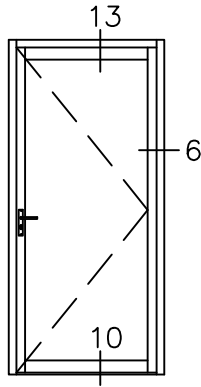
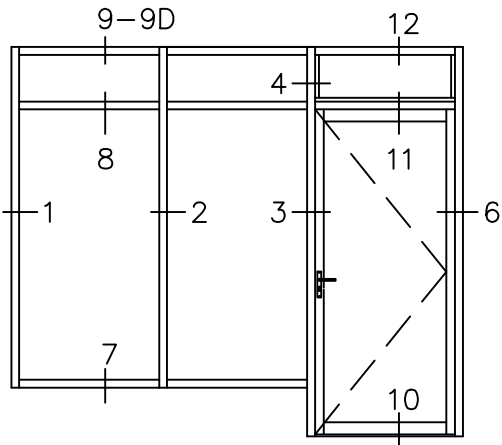

**DETAILS
2300T FRAMING**

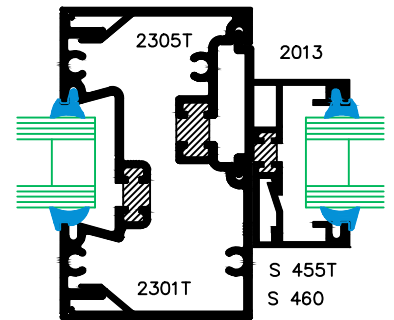

4

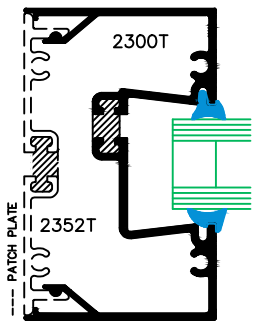

1

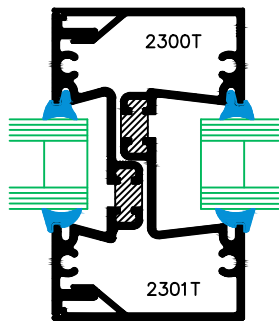

2

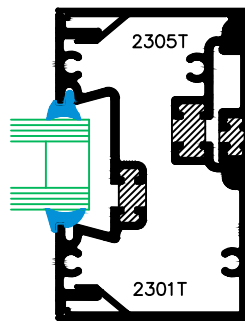

3

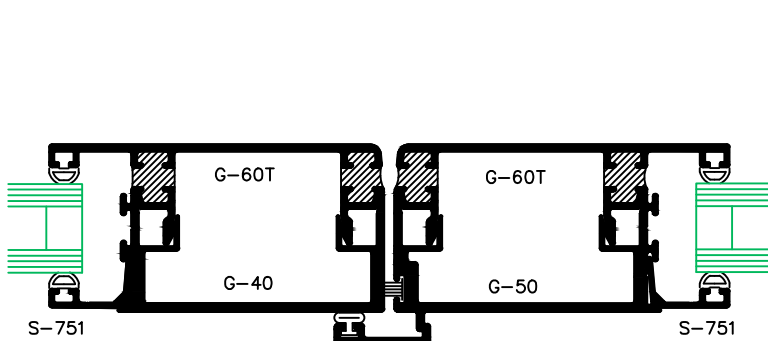
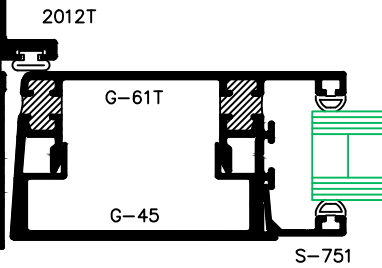

5

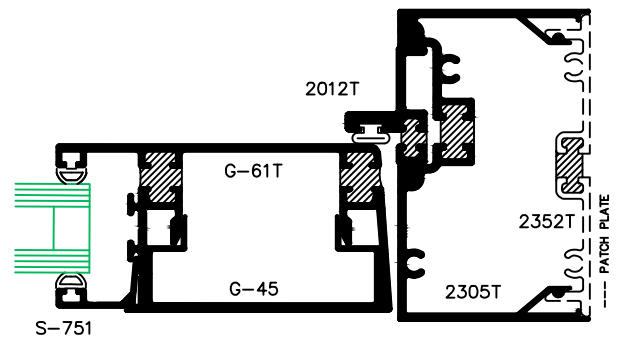

6

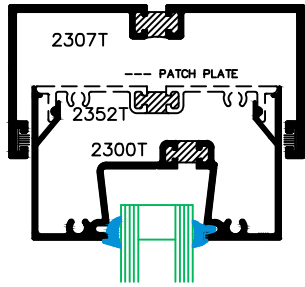

DEFLECTION HEADER OPTION

9D

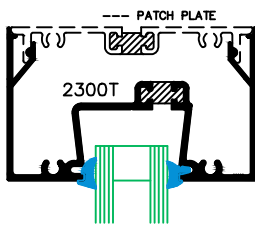

9

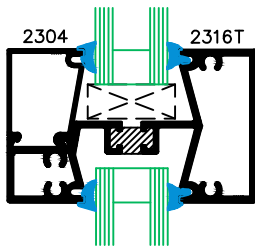

8

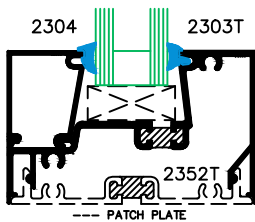

7

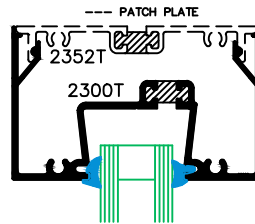

12

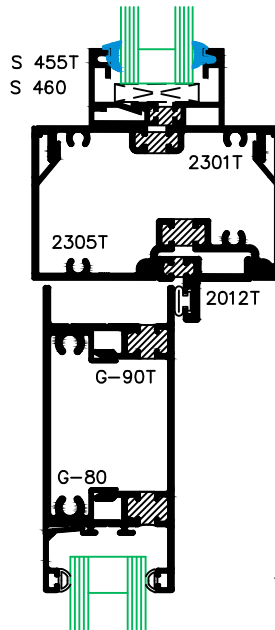

11

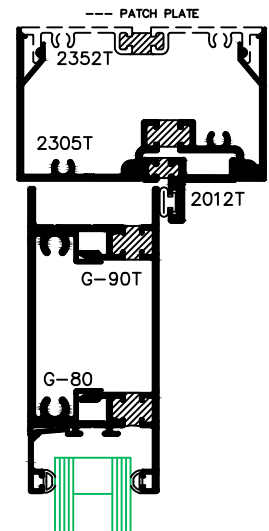

13

DETAILS
2300T FRAMING

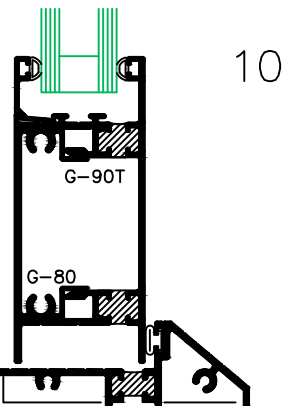

10

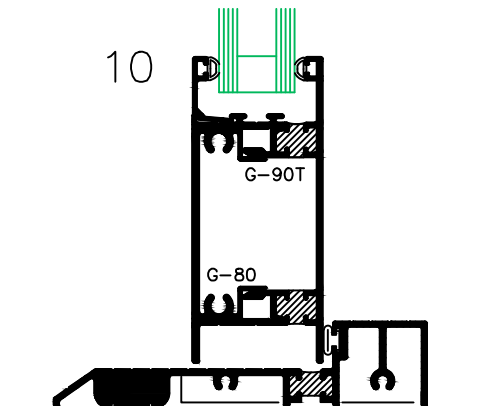

10

DETAILS
2050 FRAMING

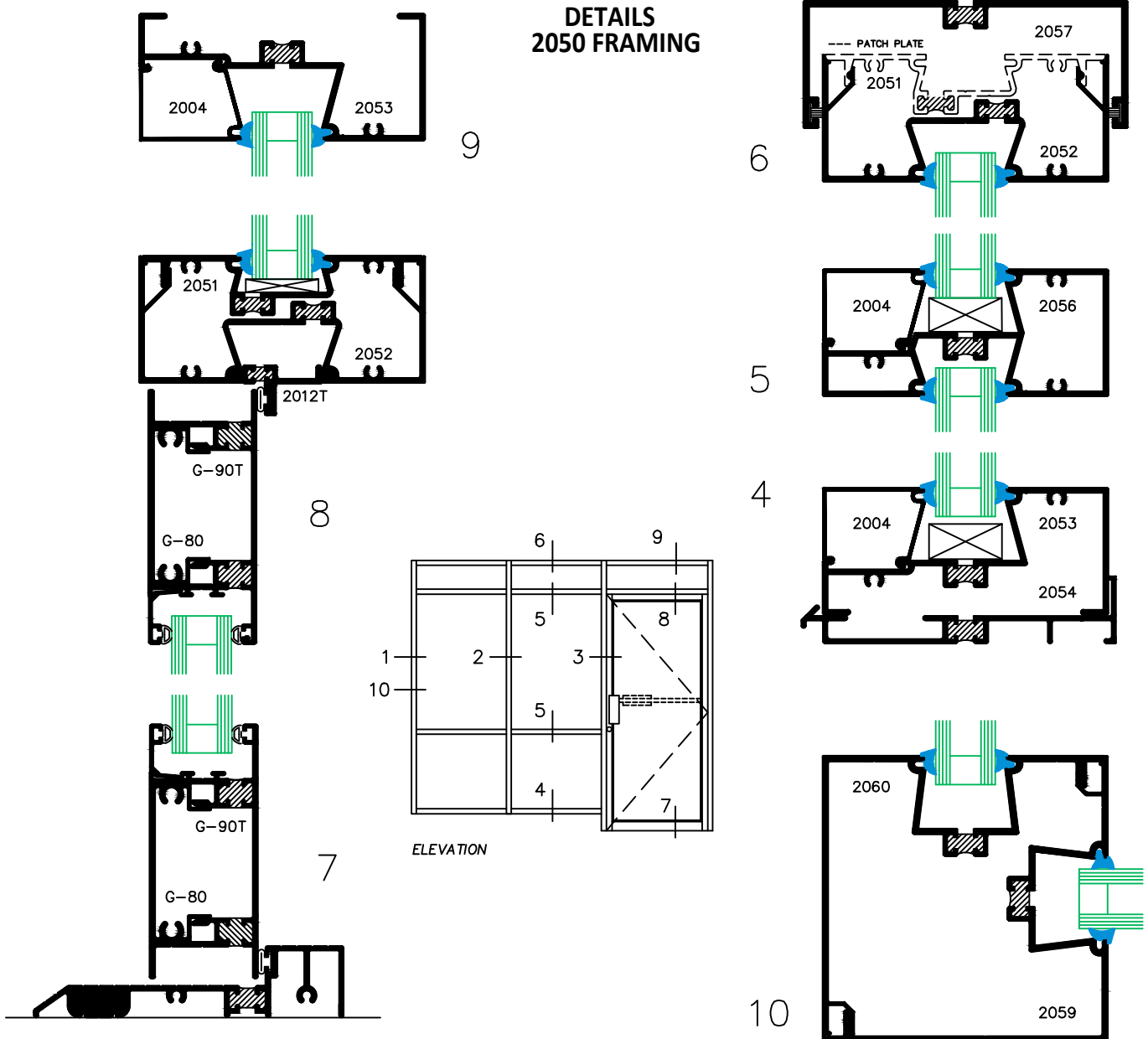

Corner Post

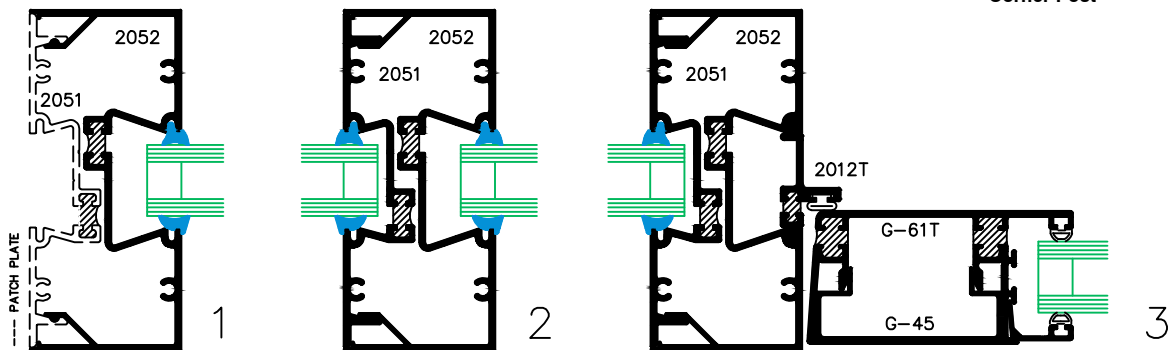



**METRO
ALUMINUM**
Products Ltd.

GLACIER 2000
RESIDENTIAL
THERMALLY BROKEN DOORS

**A
10D**

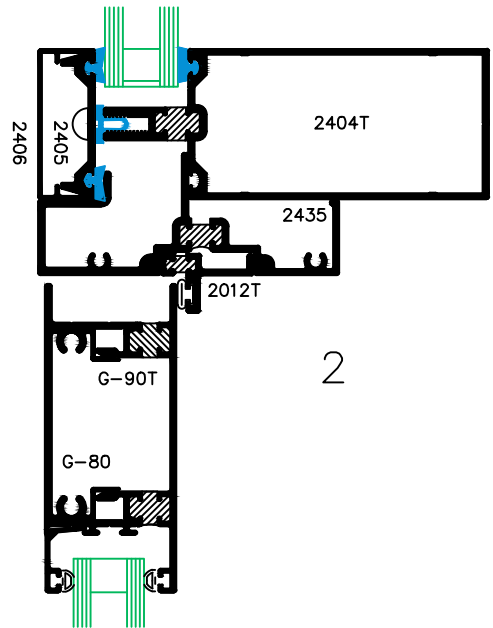
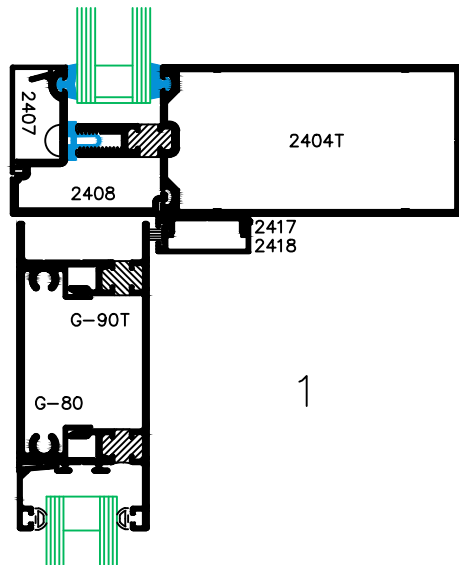

**DETAILS
2400T FRAMING**

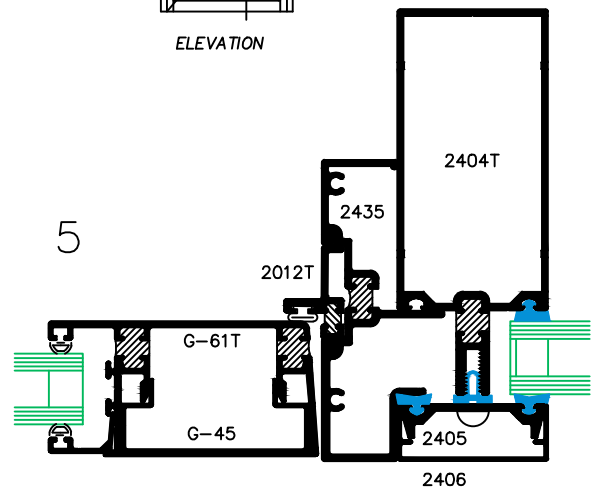
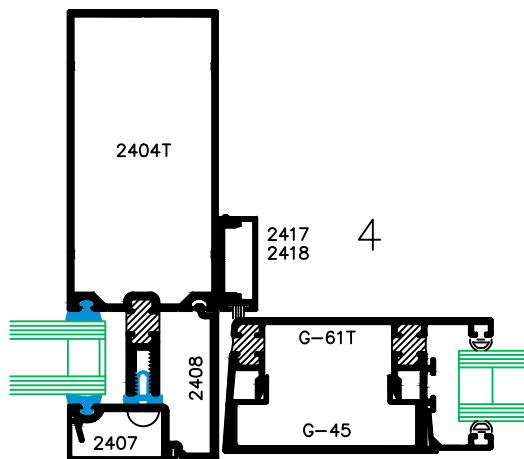
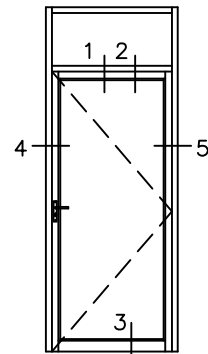
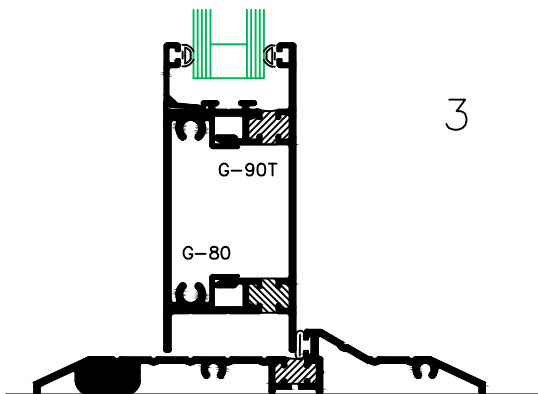

STANDARD DOOR SIZES

SINGLE DOOR OPENING	36" x 84"	914 mm x 2134 mm
PAIR OF DOORS OPENING	72" x 84"	1829 mm x 2134 mm

GLASS SIZES FOR SINGLE AND PAIRS OF 250 SERIES DOOR

5 mm SINGLE GLASS	31 7/16" x 77 1/2"	798 mm x 1969 mm
23.8mm GLASS UNIT	31 7/16" x 77 1/2"	798 mm x 1969 mm

GLASS SIZES FOR SINGLE AND PAIRS OF 350 SERIES DOOR

5 mm SINGLE GLASS	28 7/16" x 73 5/8"	722 mm x 1870 mm
23.8mm GLASS UNIT	28 7/16" x 73 5/8"	722 mm x 1870 mm

GLASS SIZES FOR SINGLE AND PAIRS OF 500 SERIES DOOR

5 mm SINGLE GLASS	25 7/16" x 70 13/16"	646 mm x 1798 mm
23.8mm GLASS UNIT	25 7/16" x 70 13/16"	646 mm x 1798 mm

PAIR OF DOORS VIEWED FROM OUTSIDE

INACTIVE LEFT LEAF	i.e. FLUSH BOLTS
INACTIVE RIGHT LEAF	i.e. LOCK and CYLINDER

AVAILABLE GLASS STOPS

5 mm GLASS	SQUARE STOP 1/2" FACE WIDTH
SINGLE GLAZED DOOR	
23.8mm GLASS UNIT	
DOUBLE GLAZED DOOR	SQUARE STOP 3/4" FACE WIDTH

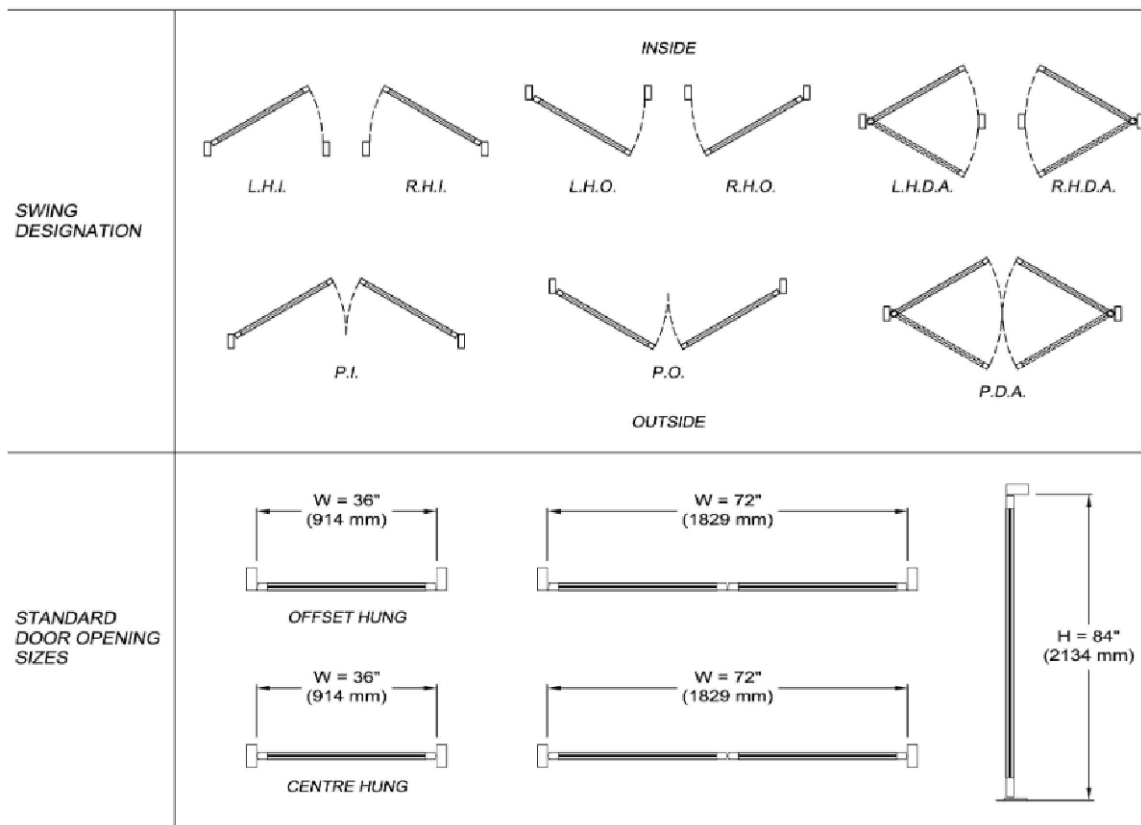

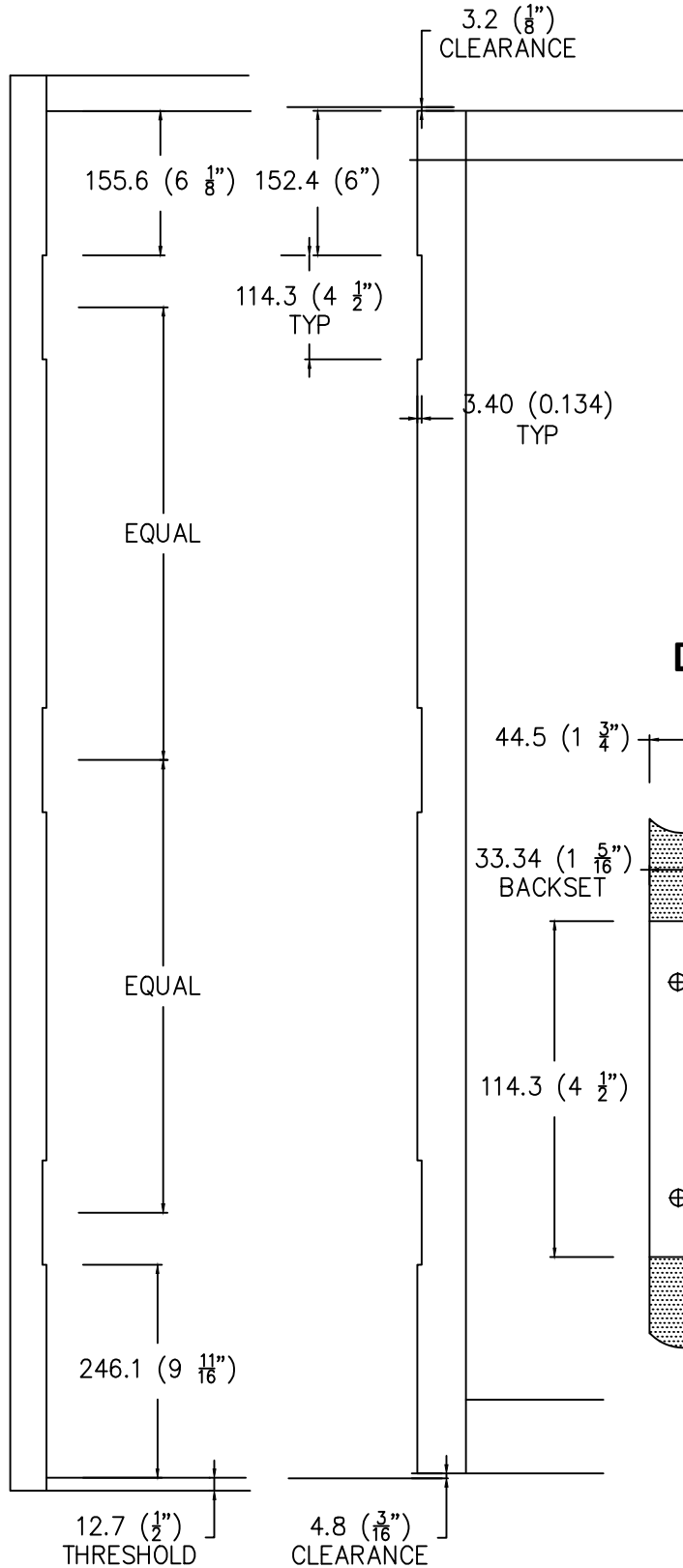

STANDARD BUTT LOCATIONS

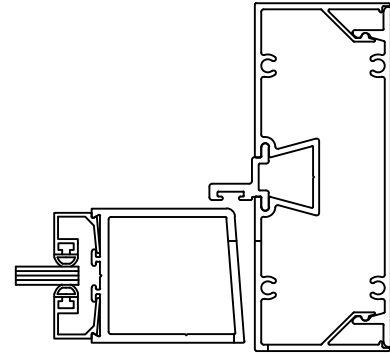

3.40 (0.134) ±

DOOR

FRAME

44.5 (1 3/4")

114.3 (4 1/2")

33.34 (1 5/16")
BACKSET

36.6 (1 7/16")
BACKSET

114.3 (4 1/2")

114.3 (4 1/2")

FRAME

DOOR

INSTALLATION DETAILS

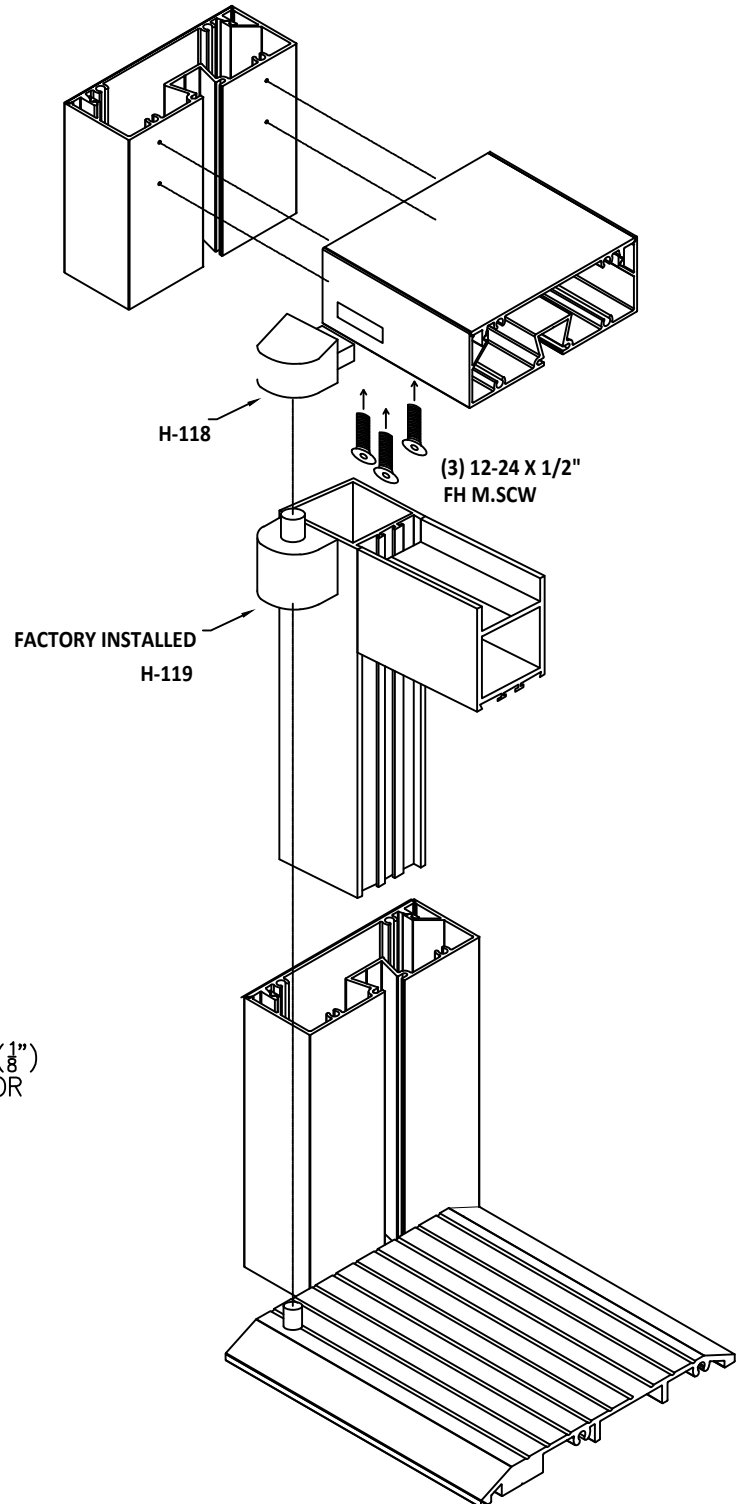
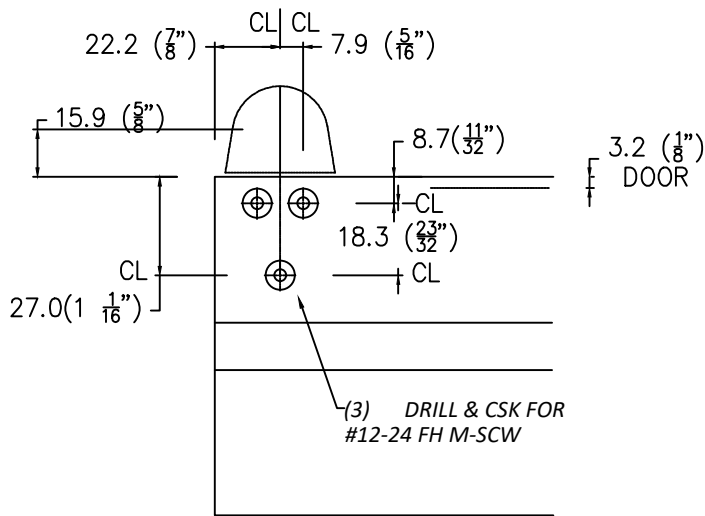
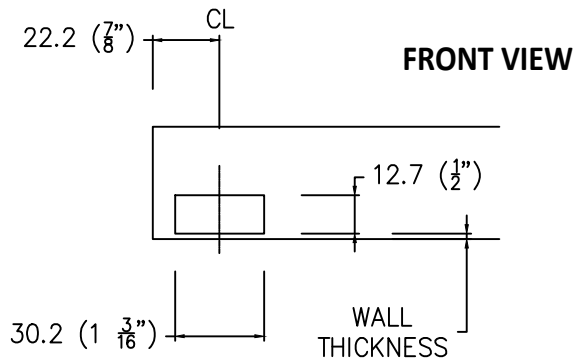



H-100A
M.S DEAD LOCK



H-102A
HOOK LOCK



H-104A
LATCH LOCK



H-104AR
A.R LATCH LOCK



H-114/H-115
KEYED CYLINDER & THUMB TURN

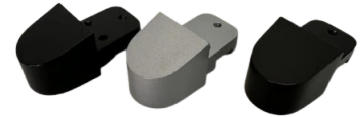

H-118
FRAME PORTION PIVOT

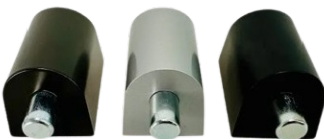

H-119
TOP DOOR PORTION PIVOT

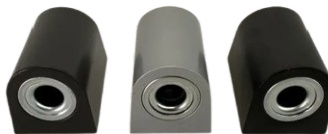

H-120
BOTTOM DOOR PORTION PIVOT



H-121
THRESHOLD PIN



H-121F
FLOOR MOUNTED PIVOT



H-250-1
METRO STANDARD PULL HANDLE



H-250-2
METRO STANDARD PUSH BAR



H-250-5
12" OFFSET D-PULL



H-250-5/H-250-5P
OFFSET D-PULL & TUBULAR PUSH BAR



H-250-6
12" B/B D-PULLS



H-250-5GLP S.S
72" X 1 1/4" OFFSET LADDER PULL



H-250-6GLP S.S
72" X 1 1/4" B/B OFFSET LADDER PULL



H-122
4" X 4 1/2" BUTT HINGE S.S



H-122 BP
4" X 4 1/2" BUTT HINGE BLACK



H-122 PKG
BUTT HINGE WITH BACK UP PLATES



H-122E
4 WIRE BUTT HINGE S.S



H-123A
4 1/2" X 4 1/2" BUTT HINGE S.S



H-124D
BUTT HINGE DOOR BACK UP PLATE



H-124F
BUTT HINGE FRAME BACK UP PLATE



H-130
METRO STANDARD CLOSER



H-130X
STANDARD CLOSER ARM EXTENSION



H-130A DR
STANDARD CLOSER DROP PLATE



H-130 DA
DELAYED ACTION CLOSER



H-128
GLOBAL TC204 CLASS 1 CLOSER



H-1300P
PARALLEL ARM BRACKET



H-4040
GLOBAL 4040 CLOSER



H-4040-18G
GLOBAL 4040 CLOSER DROP PLATE



H-4040-18PA
GLOBAL PARALLEL ARM DROP PLATE



H-4040LA
4040 CLOSER ARM EXTENSION



H-4040XLA
4040 CLOSER XL ARM EXTENSION



H-4040 HOA
4040 CLOSER HOLD OPEN ARM



H-158/H-159/H-160
CONTINUOUS HINGE



H-103AR
A.R DUAL FORCE 2190



H-100EI
EXIT INDICATOR



H-104RL
ROLLER LATCH



1550
S/G LETTER SLOT



1555
INSULATED LETTER SLOT



H-112
LEVER HANDLE

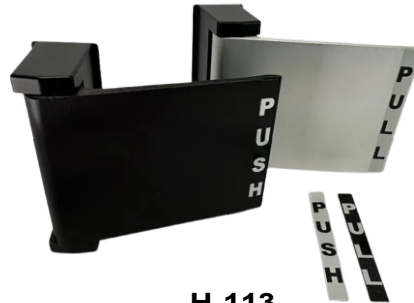

H-113
LATCH PADDLE



H-108P/H-108S
ELECTRIC STRIKES



H-110
RECTIFIER



H-111
ELECTRICAL CONNECTORS



H-104S
G.J HEAVY DUTY DOOR CLOSER



H-107
LATCH LOCK STRIKE



H-107A
LATCH DOUBLE STRIKE



H-106
CYLINDER GUARD



H-114A
GMS R-118 RIM CYLINDER



H-114B
KEY CYLINDER 1 1/8"



H-114E
2 1/4" SPINDLE EXTENSION KIT



H-116
BLACK CYLINDER



H-117
FLUSH BOLTS



H-126
INTERMEDIATE PIVOT



H-126/H-127
WALKING BEAM PIVOT SET



H-EPT2
A.R POWER TRANSFER



H-137A/B/C
ASTRAGAL



H-135
A.R 8400 PANIC



H-135S
8400 PANIC STRIKE



H-135X
8400 PANIC EXTENSION FOR 2" DOORS



H-136
A.R 8600 PANIC



H-136B
8600 PANIC STRIKE



H-136X
8600 PANIC EXTENSION FOR 2" DOORS



H-136
PS-LR POWER SUPPLY



H-136A
CYLINDER MOUNTING PAD



H-148 S.S
G.J SURFACE MOUNTED DOOR STOP

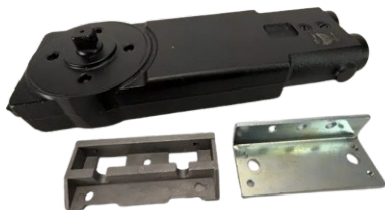

H-131
CONCEALED CLOSER



H-132
CENTER HUNG SIDE LOAD ARM



H-105
COVER PLATES



H-096

HOPPE HANDLE SET - EXTERIOR



H-096

HOPPE HANDLE SET - INTERIOR

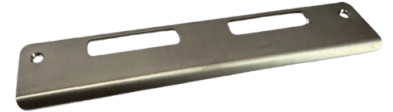

H-096AS

HOPPE LOCK STRIKE



H-096HA

GLOBAL ACTIVE HANDLE SET

Commercial and Institutional Sliding Doors

01 - General Specifications

02 - 1000 Series Multi-Track Interior Sliding Doors

- Interior use
- Multi-track parallel stacking
- Heavy duty tandem rollers
- Single or double glazed

03 - 1100 Series Monumental Patio Sliding Doors

- Exterior use
- Single or double glazed
- Full weather-stripping
- Heavy duty tandem rollers
- Stepped sill for drainage
- Screens available

04 - 1100T Series Monumental Exterior Sliding Doors

- 2 panels up to 8'0" x 8'0"
- 3 panels up to 12'0" x 8'0"
- 4 panels up to 16'0" x 8'0"
- Heavy duty tandem rollers
- Anodized and custom painted finishes
- Split-colour options
- Double thermal break
- Slopped sill track for easy drainage
- Flush finger pulls and hook lock
- Screens available

05 - Slider Hardware



Part 1 - GENERAL

Scope - The aluminum sliding door system shall be _____ Series as manufactured by METRO ALUMINUM Products Ltd. Supply and install glazed aluminum sliding doors, as described on the architectural drawings and as specified herein.

Work Not Included - See: Specifier's lists of excluded items; Items furnished but not installed and/or Items installed but not furnished.

Related Work Specified Elsewhere - See: Specifier's lists and related Sections.

Design & Performance Requirements - Sliding doors to fully comply with applicable standard specifications as typically referenced to the following performance requirements criteria: Air Tightness, Water Tightness, Wind and Other Load resistance. (Note: Applicable Specifier's selection)

Submittals - Shop Drawings & Samples - Submit all documentation and samples for review by Consultant at one time, prior to fabrication of door products.

Quality Assurance - Provide all necessary information to show that all involved products meet or exceed the requirements of these specifications.

Delivery, Storage and Handling - Deliver, store, handle, protect and schedule materials and products so as to avoid any damage. Follow recommendations of AAMA CW-10 "Care and Handling of Architectural Aluminum from Shop to Site" and others as applicable.

Part 2 - PRODUCTS

Materials - All materials to meet the minimum design and specifications as applicable. Any defects impairing strength, durability or appearance are not acceptable. Extruded aluminum shall be AA 6063 T6 alloy and temper with $F_y = 110$ MPa (16 KSI) minimum. Sufficient strength and size fasteners shall be made of corrosion-resistant and compatible material such as cadmium or zinc plated carbon steel, stainless steel or aluminum, to prevent any galvanic action (electrolytic corrosion). Standard gaskets shall be for dry-dry glazing method, extruded from dense Neoprene, EPDM, or other equal material. Gasket profile shall be designed and sized to fit tight and properly seal glass-metal interfacing. Glass setting to be compatible with glass unit seals and/or other parts involved as required. Heavy-duty pile type weather-stripping to be applied to all interfacing joints between individual panels and perimeter framing as required.

System Description System shall be (Specifier's selection) single glazed / double glazed Series: SD 1000 - Interior Multi Track Mall Sliding Door with flush recessed sill track; SD 1100 - Exterior Heavy-Duty Patio Door with fully weather-stripped stepped bottom track and double weather-stripped head, jambs and interlock - as manufactured by METRO ALUMINUM Products Ltd. Door configuration type to be: OX, XO, OOX, XOO or OXXO (Specifier's selection). System to accommodate panel sizes up to 1220 x 2440 mm (48" x 96").

Glass retention, as for dry glazing method, shall be achieved by utilizing inorganic rubber gasket on 4-sides of glass pane at interfacing with extruded aluminum glazing stop.

Head track to be equipped with woven pile to allow for necessary air tightness of the system and smooth operation of sliding panels. Interlock weather-stripping to be doubled as required. Slider operation to utilize adjustable tandem ball bearing rollers and security hook bolts. Head track to accommodate up to 19 mm (3/4") differential deflection.

Whenever substitute/alternative products are considered, supporting data to be submitted ten (10) days prior to bid date to allow for valid comparison. Approval of alternates to be confirmed in advance of bid closing by addendum only.

Fabrication - Extruded profiles shall be accurately fabricated and assembled to provide tight fit hairline joints only. Corner joinery shall utilize concealed assembly anticorrosive fasteners to allow for true and square set of frame elements. Frame assemblies shall be free of warp. Uniformly compressed glazing gaskets shall secure glass in place and uniform weather-stripping to suit air tightness and operation requirements. No exposed fasteners are permitted.

Finish - All exposed surfaces shall be finished as specified. The finish, as per AAM designation, shall be (Specifier's selection):

Standard clear anodizing to AA - M12C22A31

Standard perma bronze to AA - M12C22A44

Standard black anodized to AA - M10C21A44

Duracron acrylic enamel to AA - M12C4XR1X

Custom paint qualities and colors - Specifier's selection.

Hardware to have manufacturer's standard finish.

Part 3 - EXECUTION

Installation - Prefabricated framing to be installed in prepared openings, at correct locations as shown on drawings, set level, plumb, square and aligned with other work in accordance with manufacturer's instructions, approved shop and erection drawings. Tracks and panels to be set level, plumb and parallel not exceeding overall length combined tolerance of 3 mm (1/8") from established reference lines. Anchoring shall suit perimeter conditions of rough openings and seals as required. Perimeter joints to be sealed/caulked as specified and detailed.

Protection and Cleaning - Work to be protected from damage during and after installation. Consult with manufacturer and installer to determine appropriate protective measures. The General Contractor shall be responsible for protection during construction and for final cleaning. After installation, aluminum work and glass to be cleaned according to instructions/manuals provided by product manufacturers and glaziers. Use appropriate cleaning materials and methods. Do not scratch or damage glass or finishes.



ELEVATIONS & PLAN DETAILS

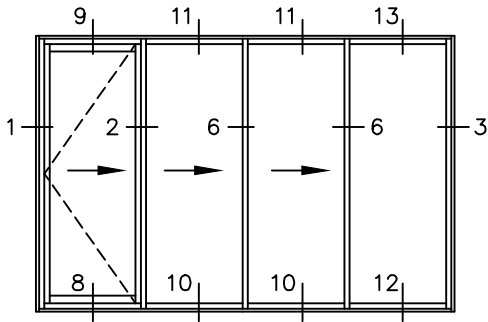

ELEVATION

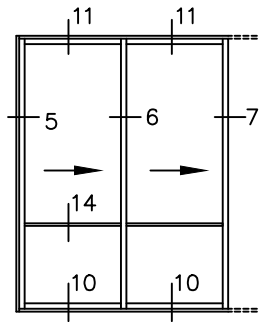

ELEVATION

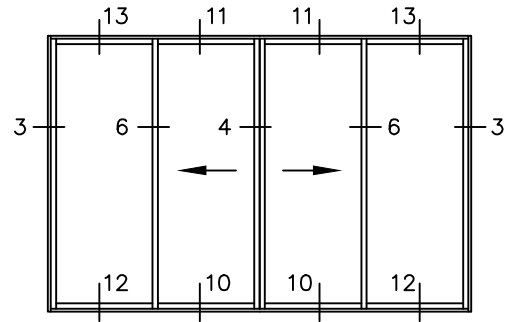

ELEVATION

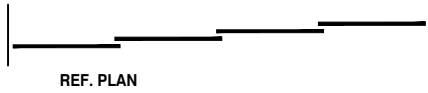

REF. PLAN

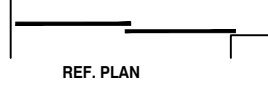

REF. PLAN

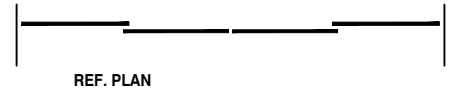

REF. PLAN

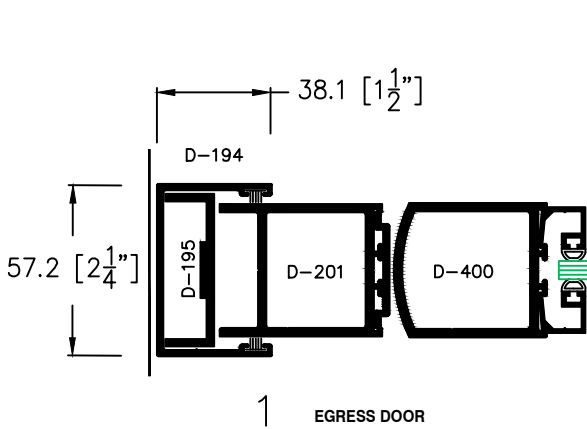

1 EGRESS DOOR

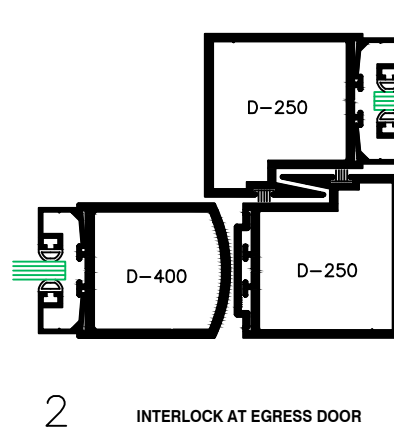

2 INTERLOCK AT EGRESS DOOR

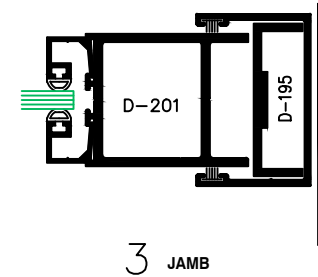

3 JAMB

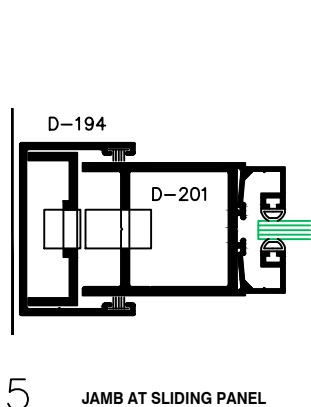

5 JAMB AT SLIDING PANEL

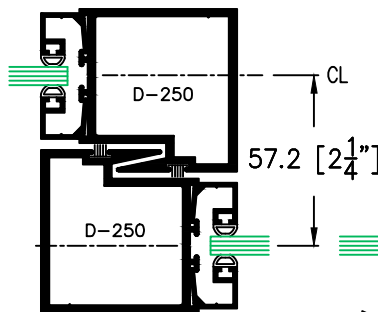

6 INTERLOCK

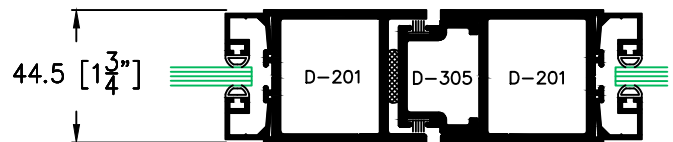

4 MEETING

7 JAMB AT WALL

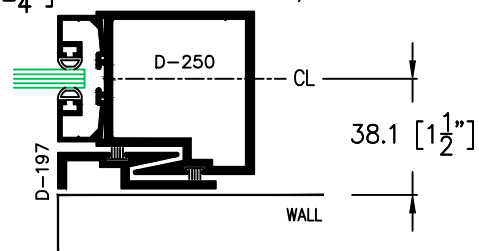

SECTION DETAILS

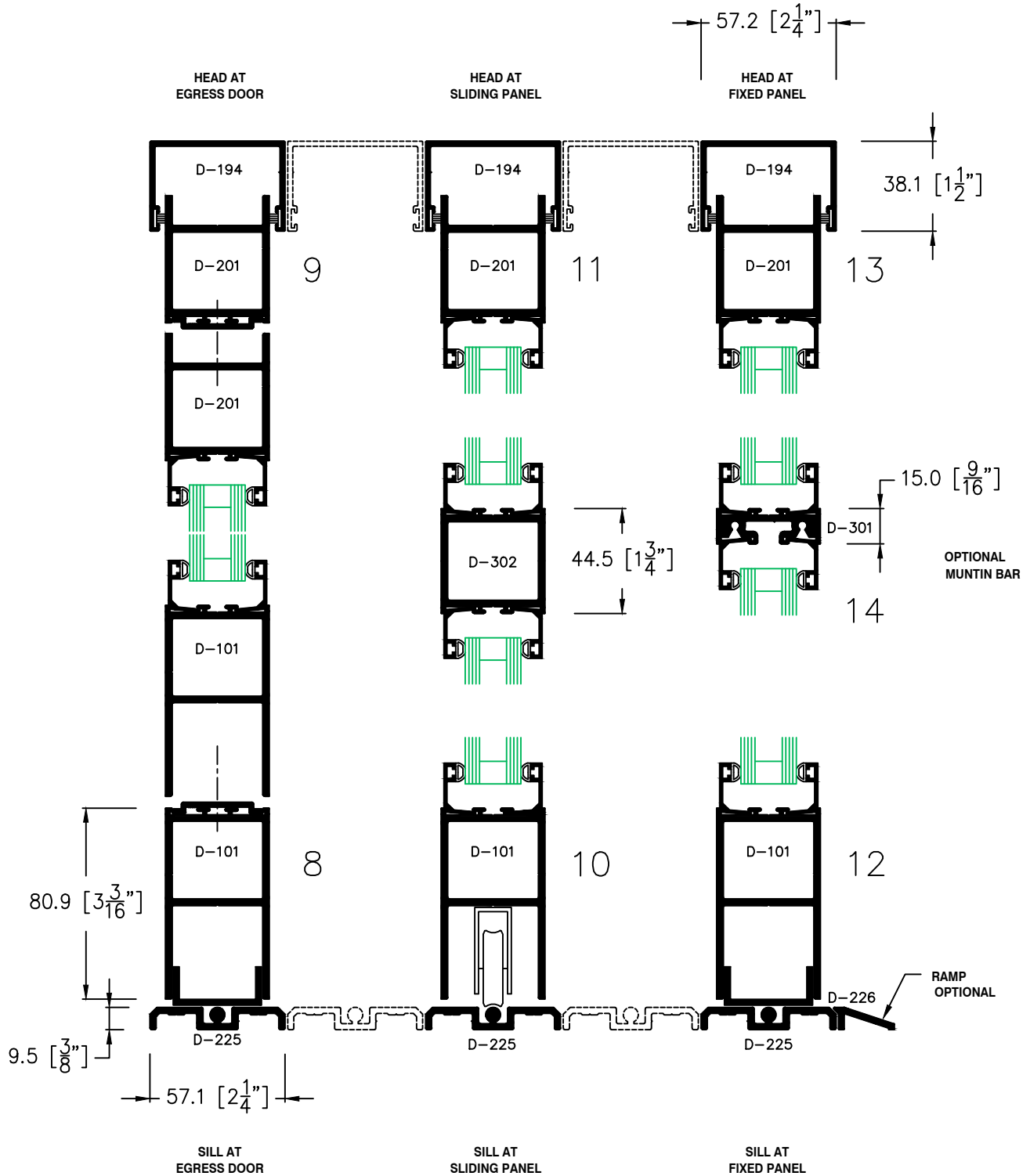



SECTION DETAILS

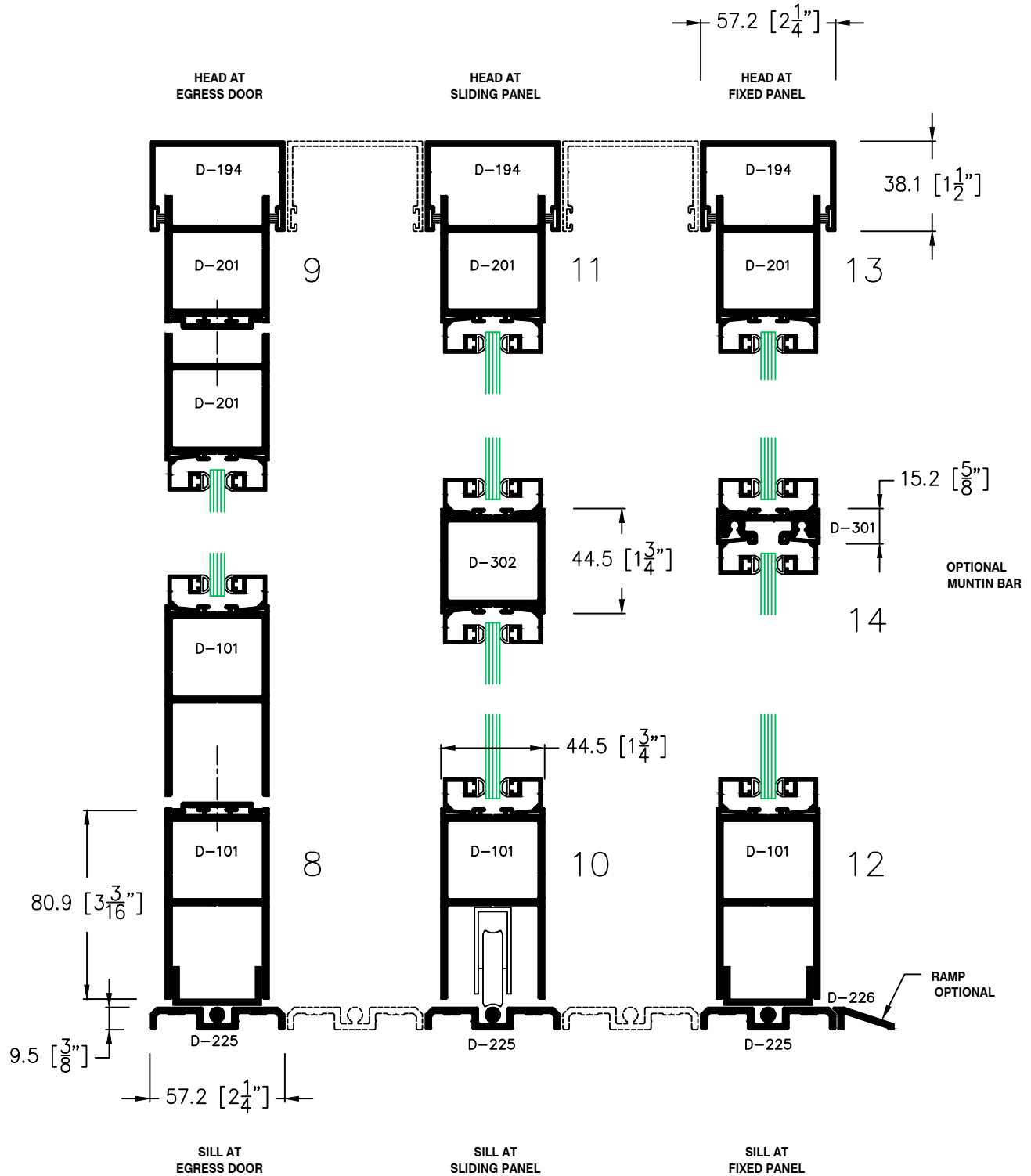



TYPICAL DETAILS

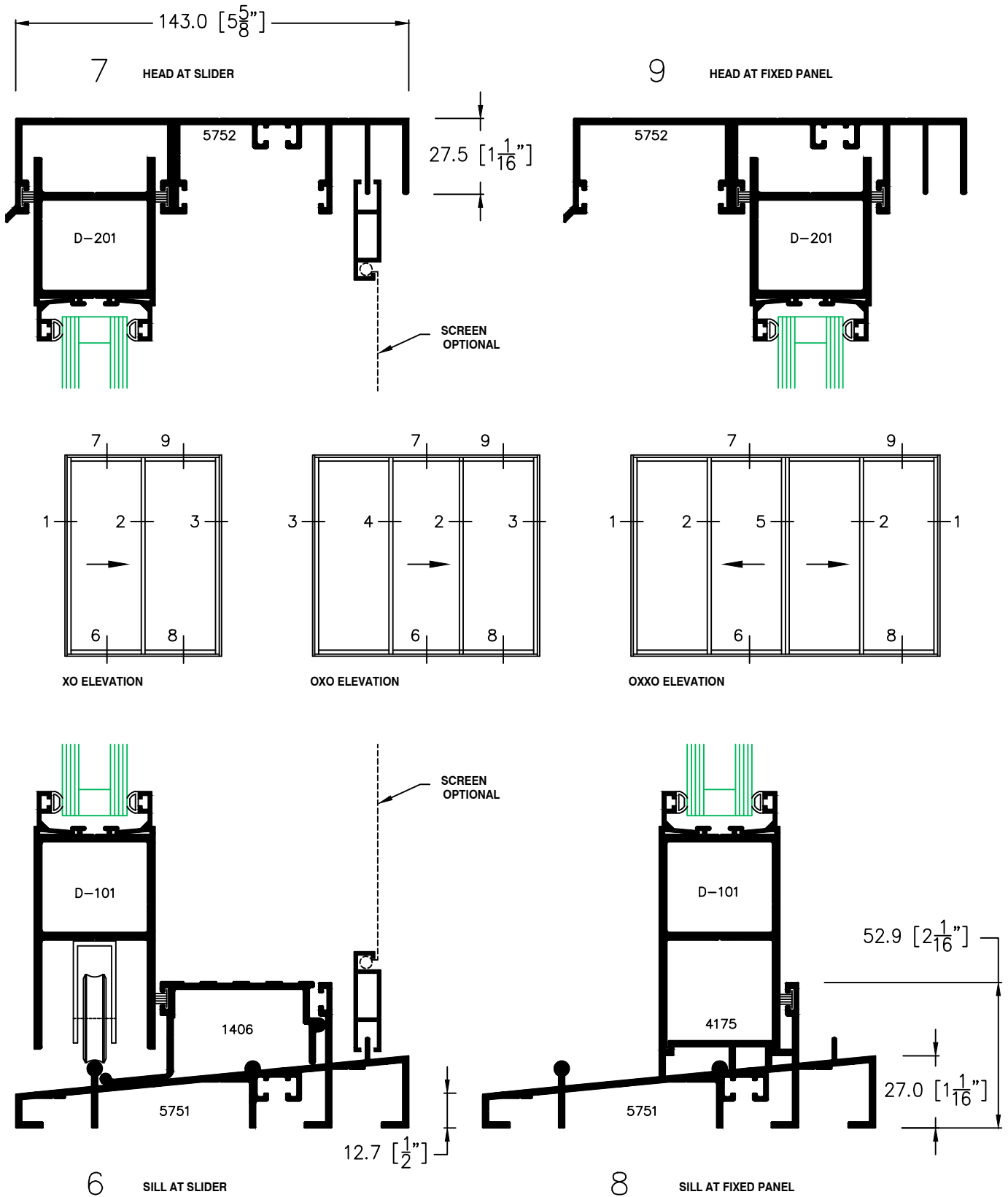

TYPICAL DETAILS

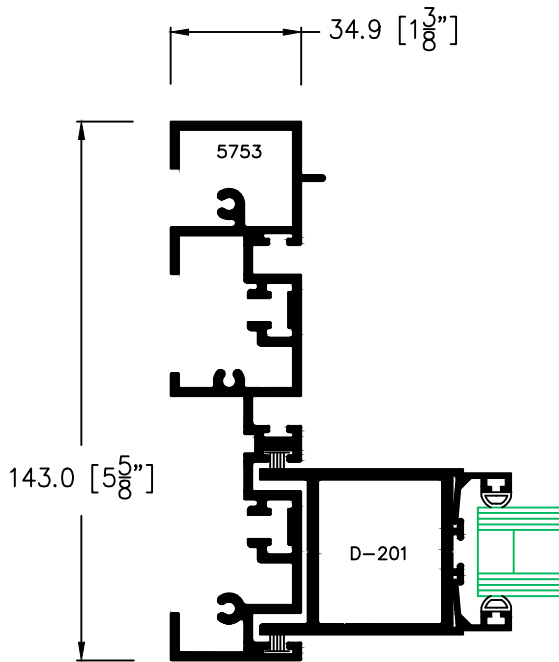

1 JAMB AT SLIDER

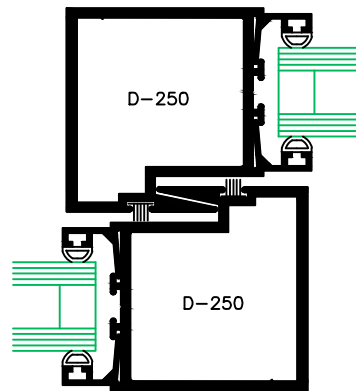

2 INTERLOCK

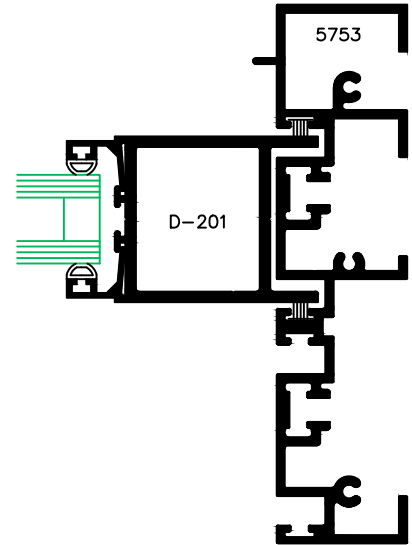

3 JAMB AT FIXED PANEL

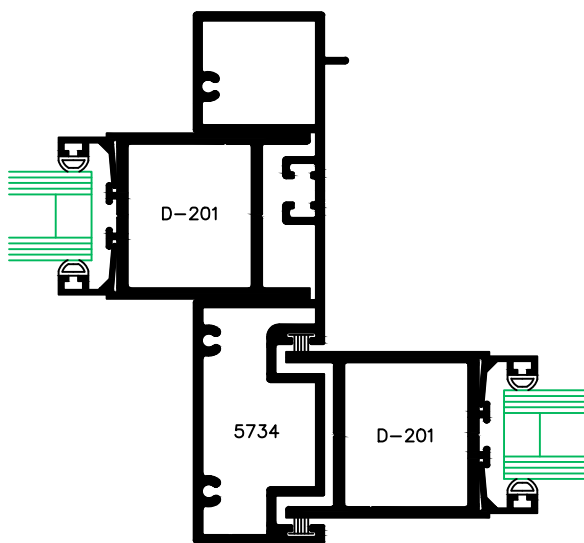

4 OXO

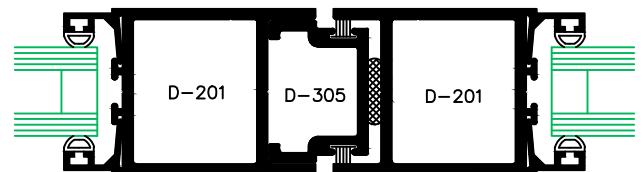

5 OXO MEETING STILE



TYPICAL DETAILS

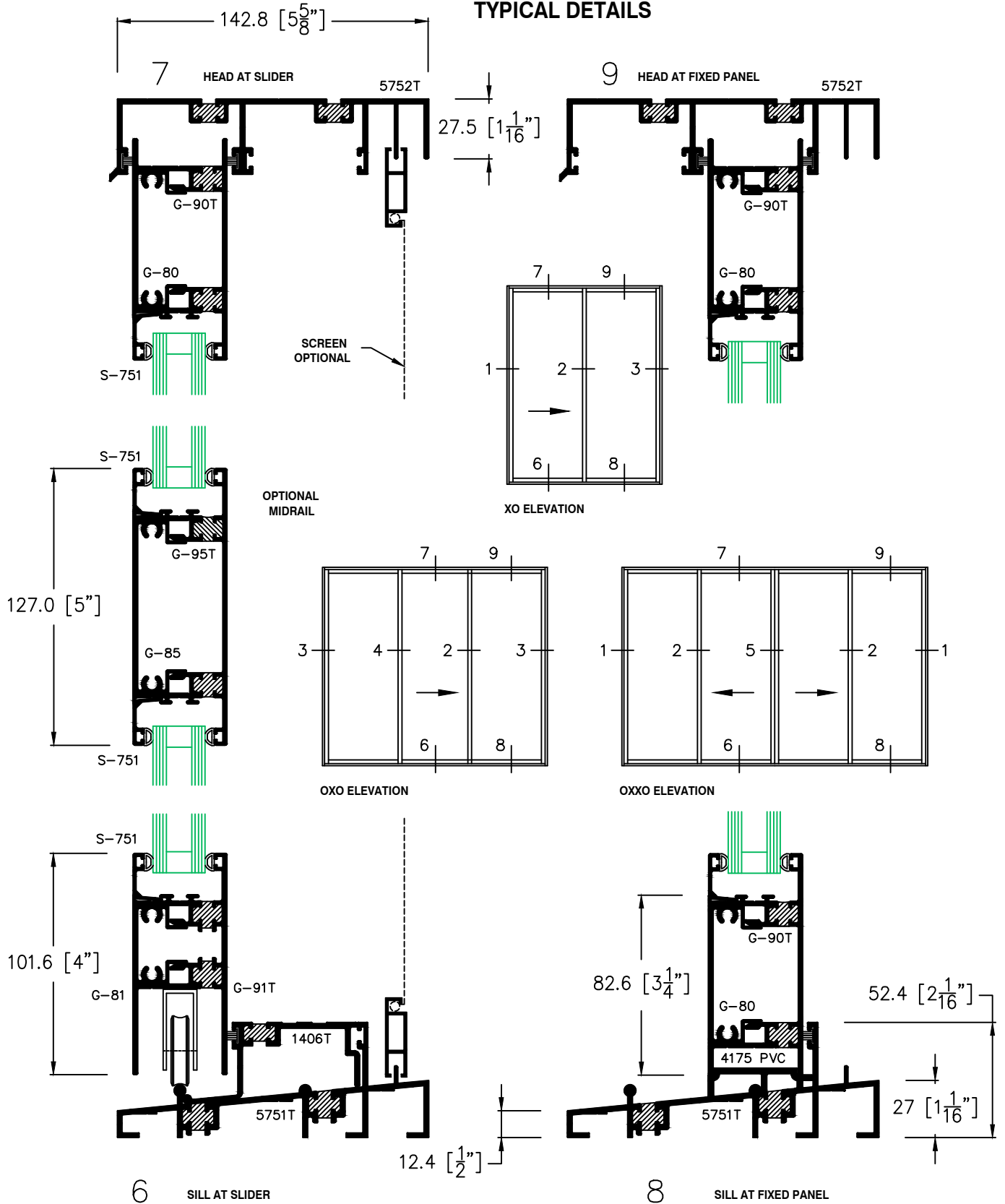



TYPICAL DETAILS

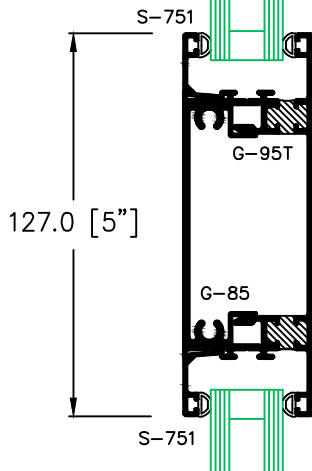
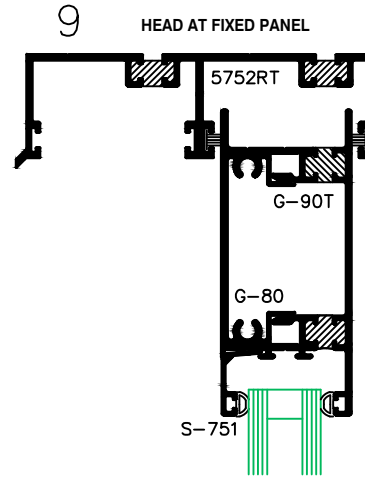
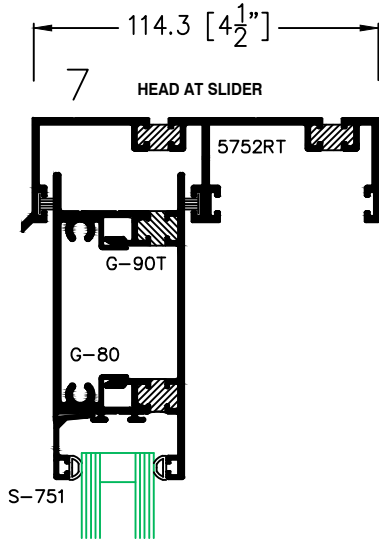

OPTIONAL
MIDRAIL

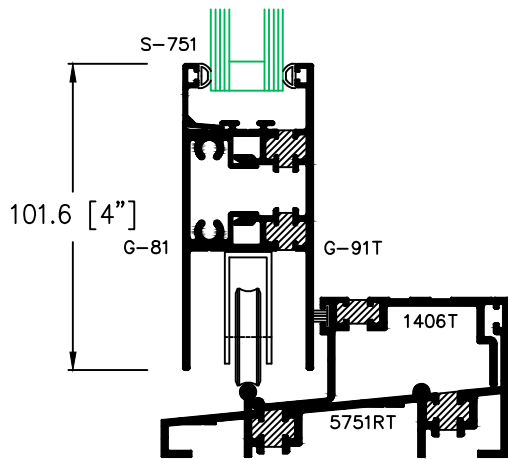
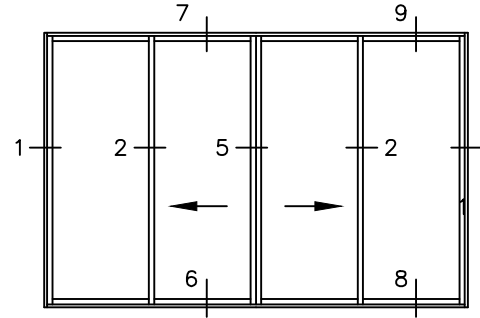
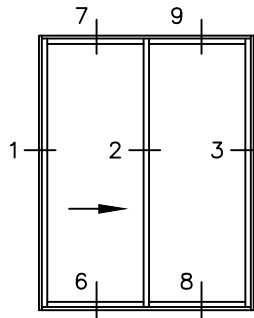

6 SILL AT SLIDER

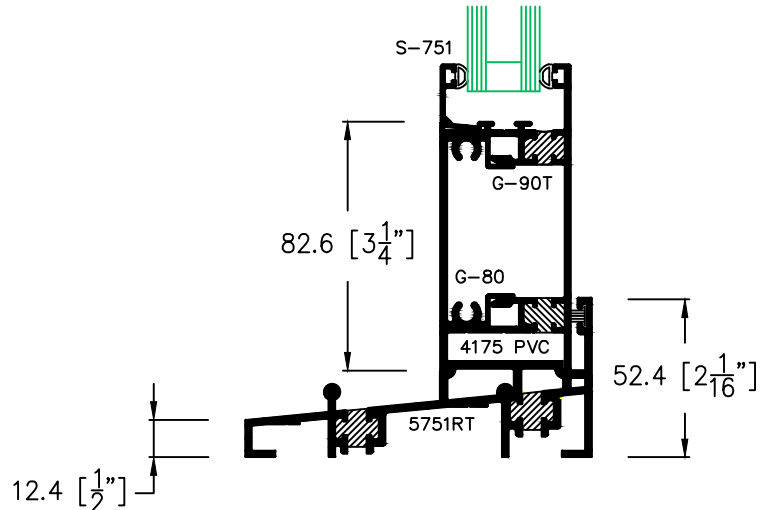

8 SILL AT FIXED PANEL

TYPICAL DETAILS

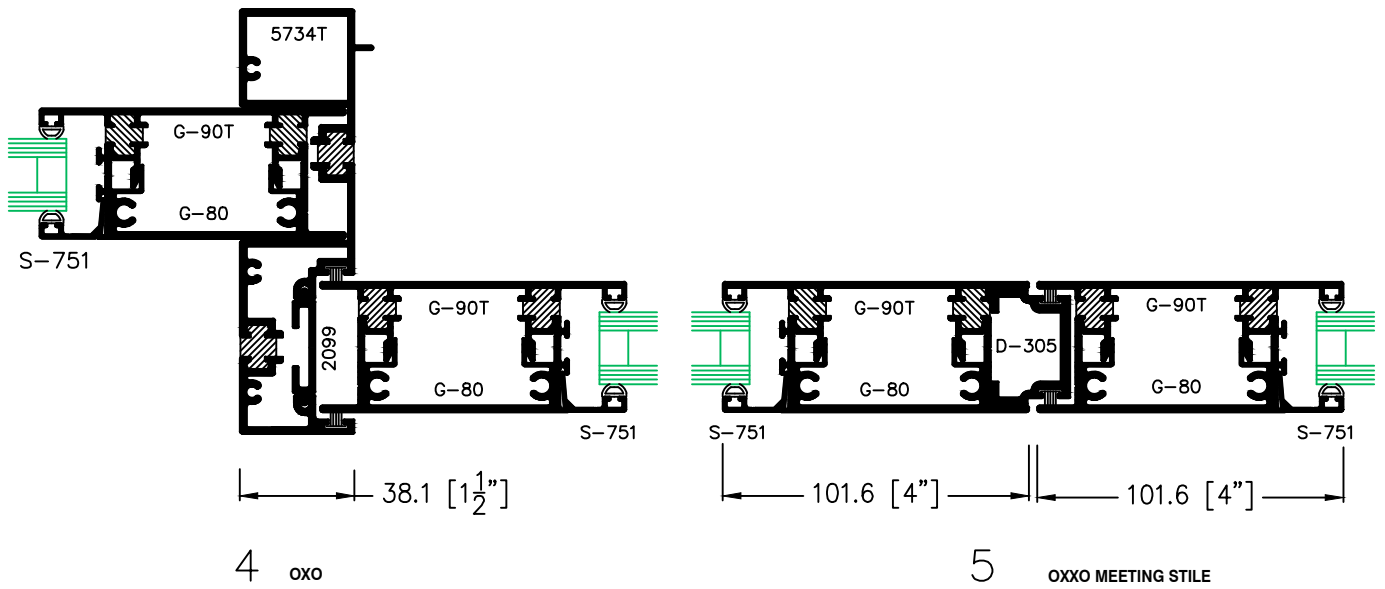
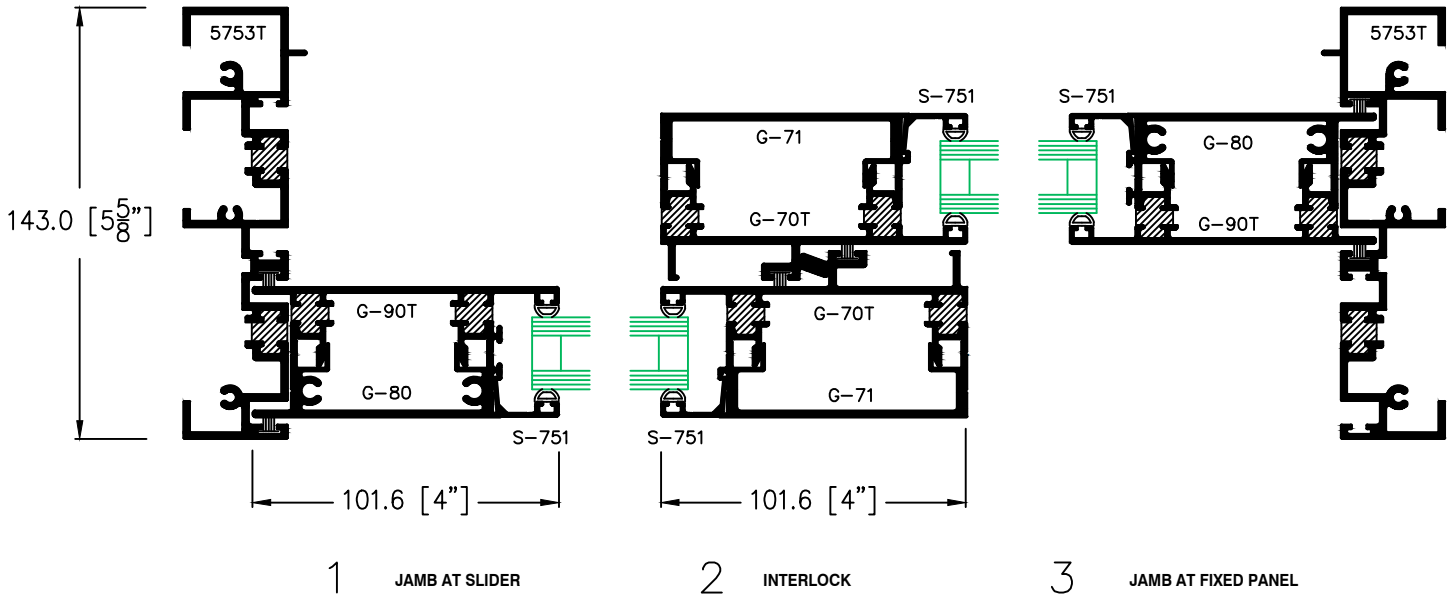

TYPICAL DETAILS



INTO CURTAIN WALL FRAMING

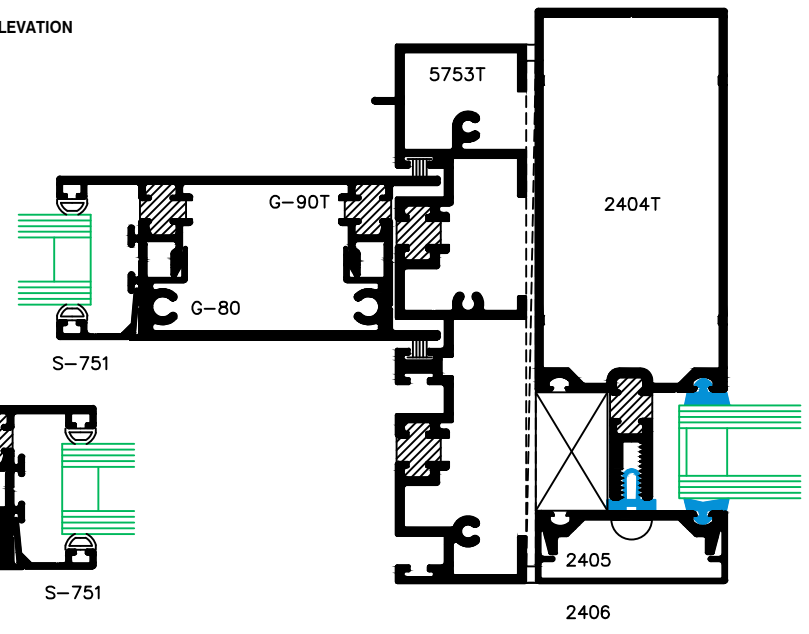
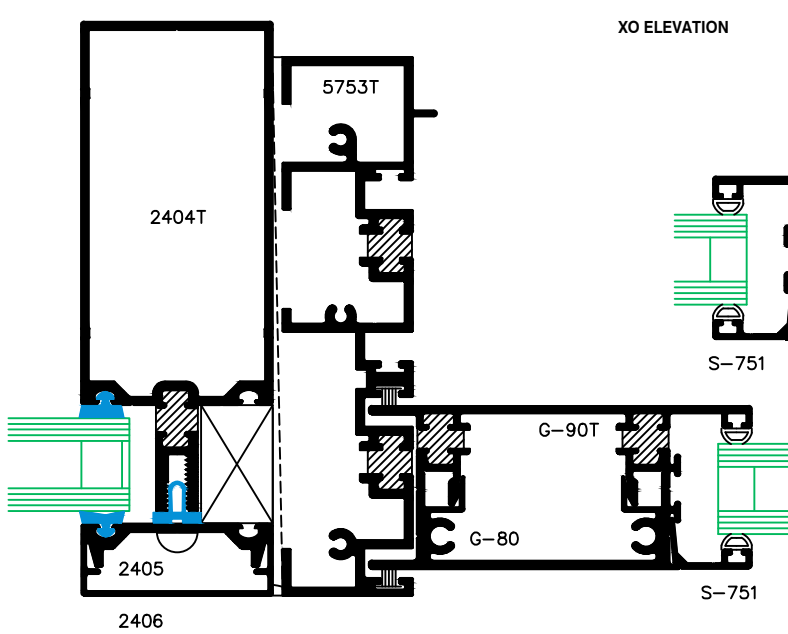
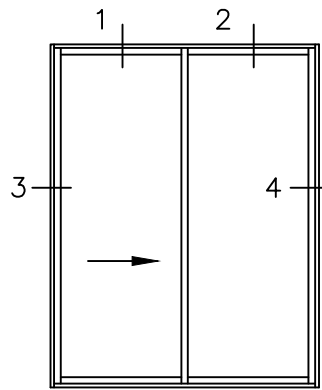
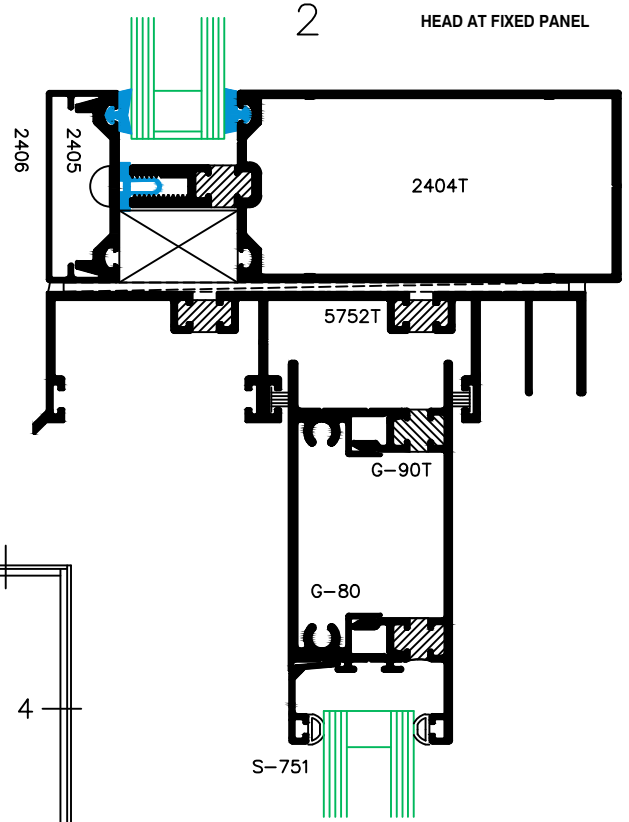
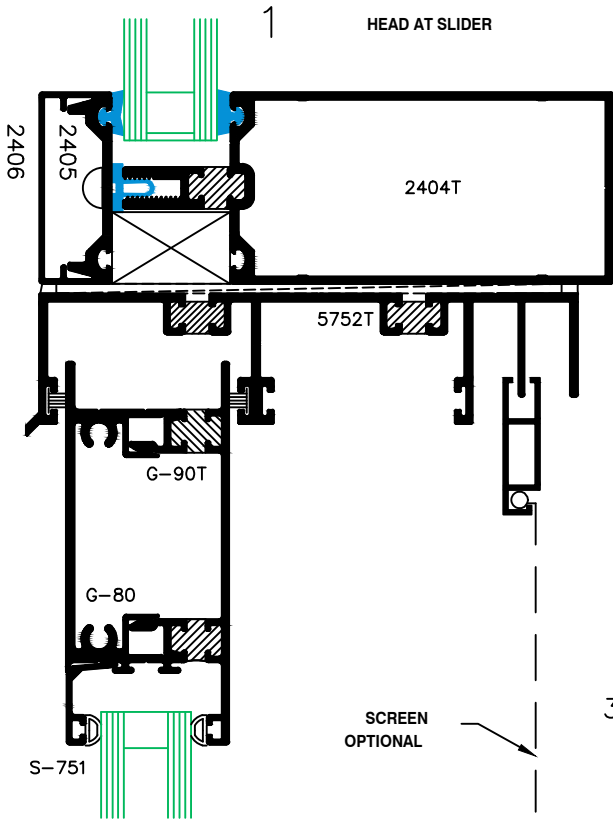

INTO CURTAIN WALL FRAMING

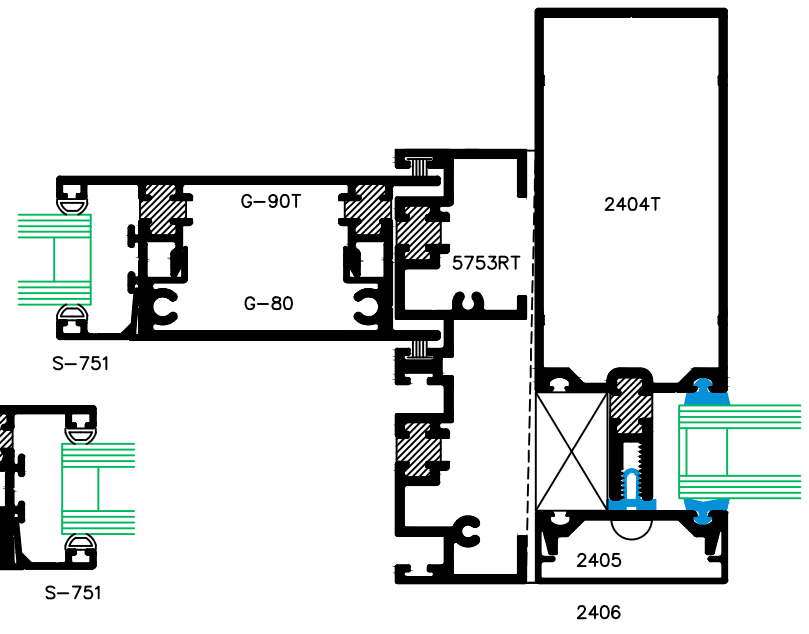
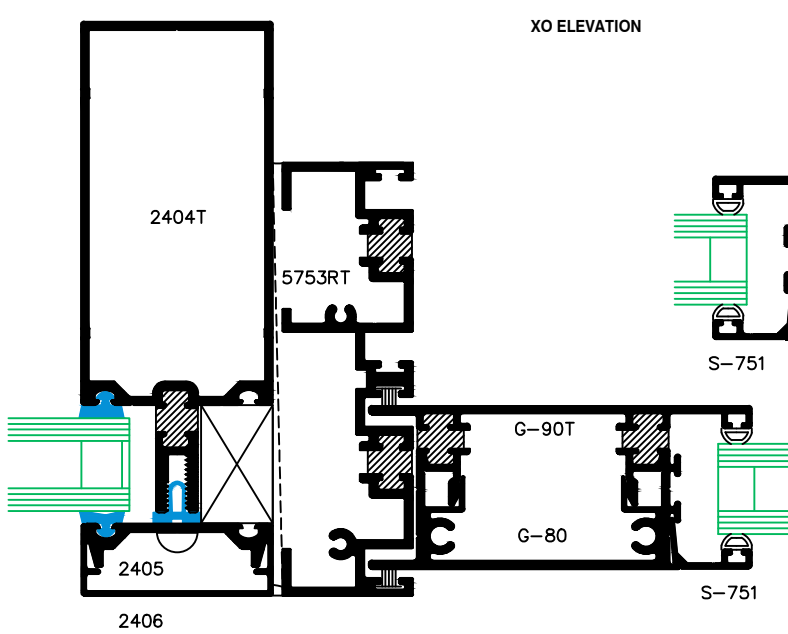
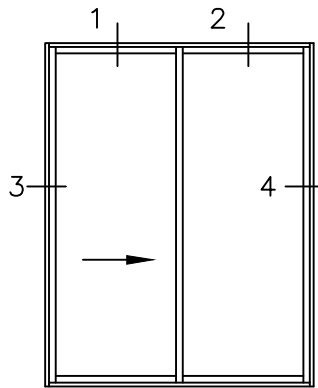
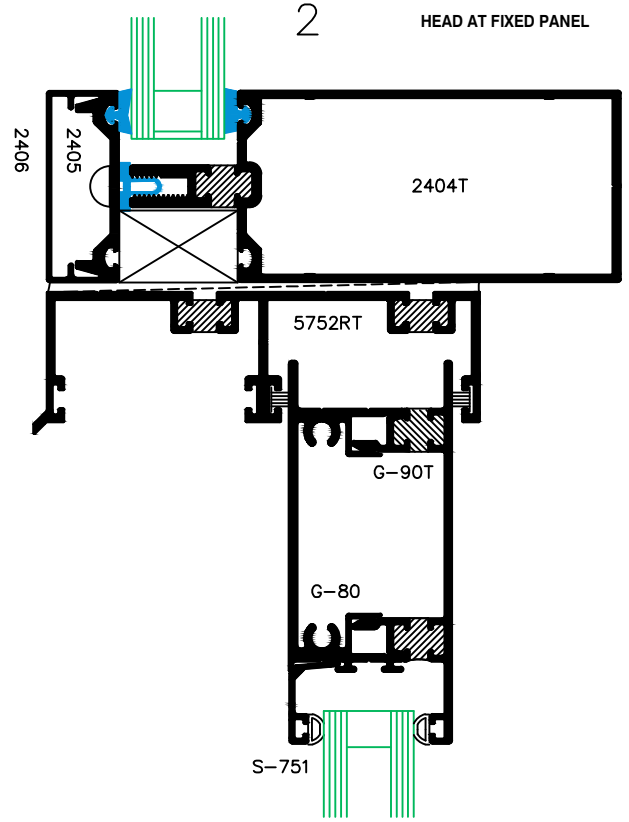
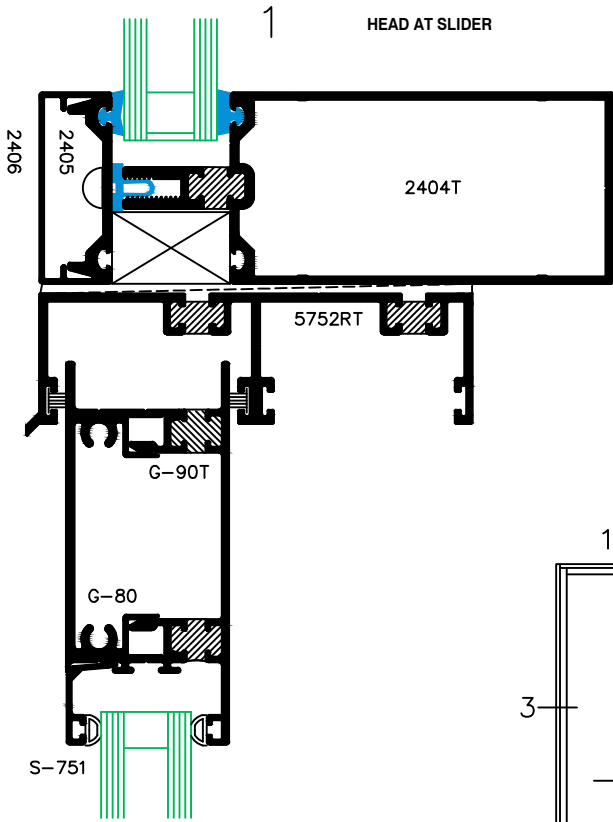



H-90
TANDEM SLIDER ROLLER



H-90 S.S
TANDEM SLIDER ROLLER STAINLESS



H-91
SLIDER FINGER PULL



H-92
SLIDER FINGER PULL - KEYED



H-93
SLIDER FINGER PULL - NO KEY



H-94
SLIDER FINGER PULL - BLANK



H-096L
SLIDER SINGLE POINT LOCK



H-102
M.S HOOK LOCK 31/32" BS



PD/BUMP
PATIO SLIDER BUMPERS



PD/HAND
PATIO SLIDER SCREEN HANDLE



PD/WHL
PATIO SLIDER SCREEN WHEEL



PD/COR
PATIO SLIDER SCREEN INTERNAL CORNER



H-95
ANGLE WITH BUMPER PUSH IN



H-95
RUBBER BUMPER PUSH IN



H-105
COVER PLATE

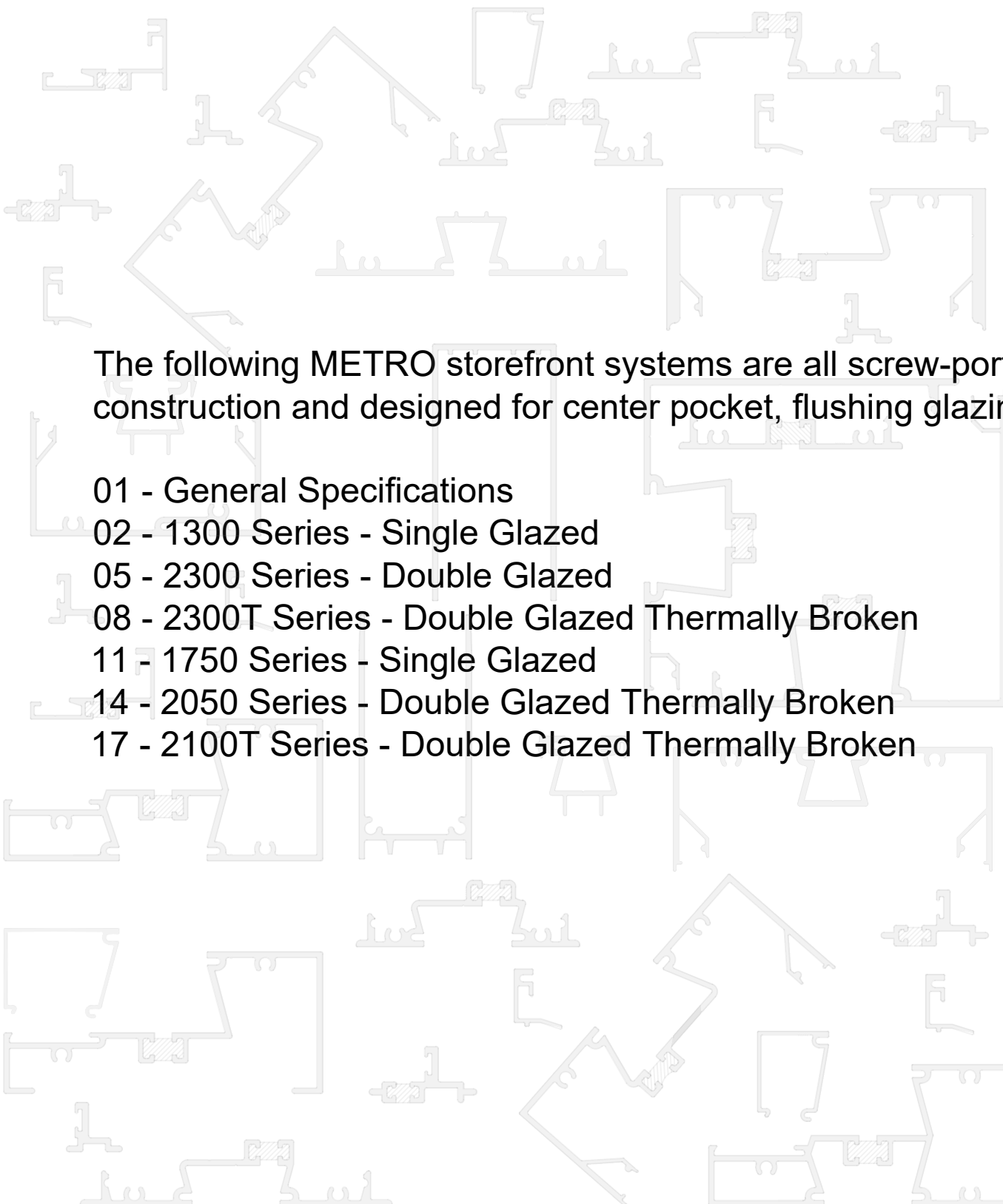

The following METRO storefront systems are all screw-port construction and designed for center pocket, flushing glazing

01 - General Specifications

02 - 1300 Series - Single Glazed

05 - 2300 Series - Double Glazed

08 - 2300T Series - Double Glazed Thermally Broken

11 - 1750 Series - Single Glazed

14 - 2050 Series - Double Glazed Thermally Broken

17 - 2100T Series - Double Glazed Thermally Broken

Part 1 - GENERAL

Scope - The storefront framing system shall be _____ Series as manufactured by METRO ALUMINUM Products Ltd. Supply and install aluminum framing, as described on the architectural drawings and as specified herein.

Work Not Included - See: Specifier's lists of excluded items; Items furnished but not installed and/or Items installed but not furnished.

Related Work Specified Elsewhere - See: Specifier's lists and related Sections.

Design & Performance Requirements - Framing to fully comply with applicable standard specifications as typically referenced to the following performance requirements criteria: Air Tightness, Water Tightness, Wind and Other Load resistance, Temperature Index and Energy Performance. (Specifier's selection)

Submittals - Shop Drawings & Samples - Submit all documentation and samples for review by Consultant at one time, prior to fabrication of door products.

Quality Assurance - Provide all necessary information to show that all involved products meet or exceed the requirements of these specifications.

Delivery, Storage and Handling - Deliver, store, handle, protect and schedule materials and products so as to avoid any damage. Follow recommendations of AAMA CW-10 "Care and Handling of Architectural Aluminum from Shop to Site" and others as applicable.

Part 2 - PRODUCTS

Materials - All materials to meet the applicable minimum design and specifications requirements. Any defects impairing strength, durability or appearance are not acceptable. Extruded aluminum shall be AA 6063 T6 alloy and temper - Fy = 110 MPa (16 KSI) minimum. Sufficient strength and size fasteners shall be made of corrosion-resistant and compatible material such as cadmium or zinc plated carbon steel, stainless steel or aluminum, to prevent any galvanic action (electrolytic corrosion). Standard gaskets shall be extruded from dense Neoprene, EPDM, or other equal material. Gasket profiles, for dry-dry, outside-flush glazing method, shall be designed and sized to fit tight and properly seal glass-metal interfacing. Glass setting to be compatible with glass unit seals and/or other parts involved as required.

System Description - Framing System shall be 1750, 2000, 2050, 1300, 2300 - non-thermally broken/uninsulated (thermally broken/insulated - T), for single glass (sealed insulating glass units) METRO Series - Specifier selection - as manufactured by METRO ALUMINUM Products Ltd.

Reference dimensions of extruded profiles shall be:
1750 - 1.75" (44.5 mm) x 4.5" (114.3 mm) - 0.5" (12.7 mm) GP - NTB
2100 - 2" (50.8 mm) x 4.5" (114.3 mm) - 1.25" (37.7 mm) GP - TB
2050 - 2" (50.8 mm) x 4.5" (114.3 mm) - 1.25" (37.7 mm) GP - TB

1300 - 1.75" (44.5 mm) x 3.25" (82.6 mm) - 0.5" (12.7 mm)

GP - NTB

2300 - 2" (50.8 mm) x 3.25" (82.6 mm) - 1.25" (37.7 mm) GP - NTB

2300T - 2" (50.8 mm) x 3.25" (82.6 mm) - 1.25" (37.7 mm) GP - TB

Glass retention, as for dry-flush glazing method, shall be achieved by 3-side fixed pockets and a sill glazing stop profile and inorganic rubber gasket. Where applicable, thermal break shall be polyurethane poured-in resin type.

Whenever substitute/alternative products are considered, supporting data to be submitted ten (10) days prior to bid date to allow for valid comparison. Approval of alternates to be confirmed in advance of bid closing by addendum only.

Fabrication - Extruded profiles shall be accurately fabricated and assembled to provide tight fit hairline joints only. Corner joinery shall utilize concealed assembly screws or spigots. Parts involved shall be fastened by means of anticorrosive steel screws to allow for permanent true and square set of frame elements. Frame assemblies shall be free of warp. Uniformly compressed glazing gaskets shall secure glass in place. No exposed fasteners are permitted.

Finish - All exposed surfaces shall be finished as specified. The finish, as per AAM designation, shall be (Specifier's selection):

Standard clear anodizing to AA - M12C22A31

Standard perma bronze to AA - M12C22A44

Standard black anodized to AA - M10C21A44

Duracron acrylic enamel to AA - M12C4XR1X

Custom paint qualities and colors - Specifier's selection.

Hardware to have manufacturer's standard finish.

Part 3 - EXECUTION

Installation - Extruded subsills, completed with integrated end dams, to be set and sealed as required. Prefabricated framing to be installed in prepared openings, at correct locations as shown on drawings, set level, plumb, square and aligned with other work in accordance with manufacturer's instructions, approved shop and erection drawings.

Anchoring shall suit perimeter conditions of rough openings and seals as required. Perimeter joints to be sealed/caulked as specified and detailed to ensure weathertight assembly.

Protection and Cleaning - Work to be protected from damage during and after installation. Consult with manufacturer and installer to determine appropriate protective measures. The General Contractor shall be responsible for protection during construction and for final cleaning. After installation, aluminum work and glass to be cleaned according to instructions/manuals provided by product manufacturers and glaziers. Use appropriate cleaning materials and methods. Do not scratch or damage glass or finishes.



**METRO
ALUMINUM**

Products Ltd.

1300 SERIES

SINGLE GLAZING STOREFRONT SYSTEM
1 3/4" X 3 1/4" (44.5mm X 82.6mm)

C





**METRO
ALUMINUM**

Products Ltd.

1300 SERIES

SINGLE GLAZING STOREFRONT SYSTEM
1 3/4" X 3 1/4" (44.5mm X 82.6mm)

**C
02**

COMPONENTS

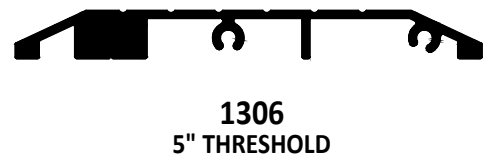
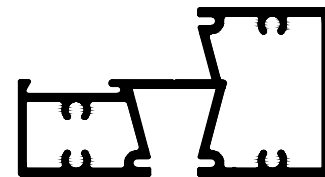
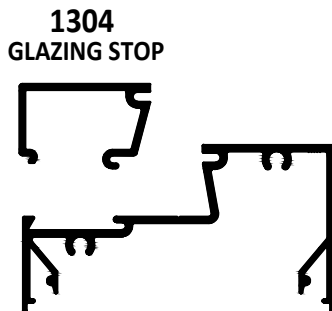
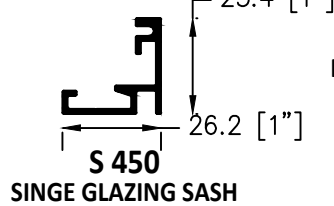
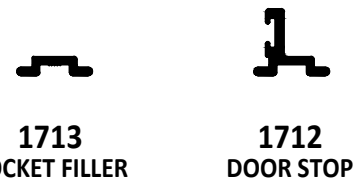
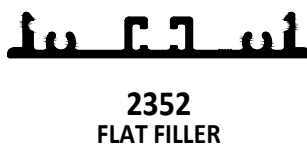
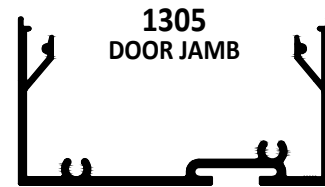
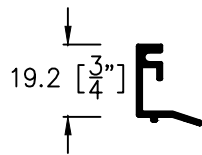
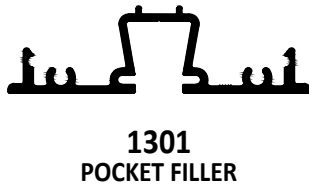
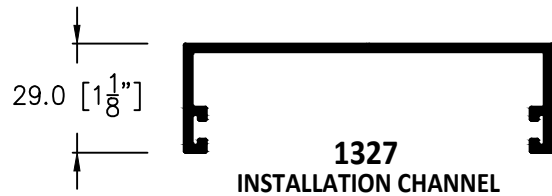
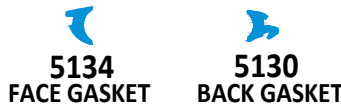
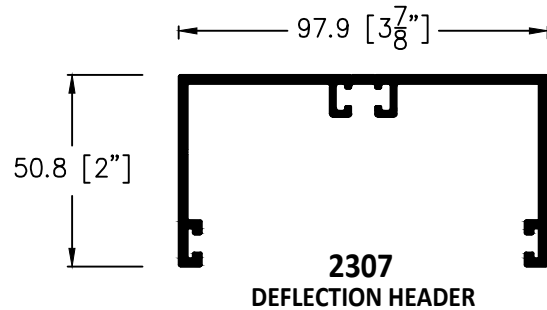
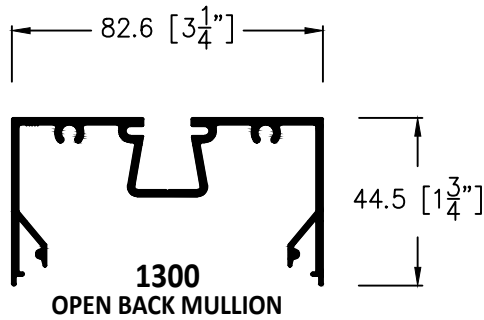



TYPICAL DETAILS

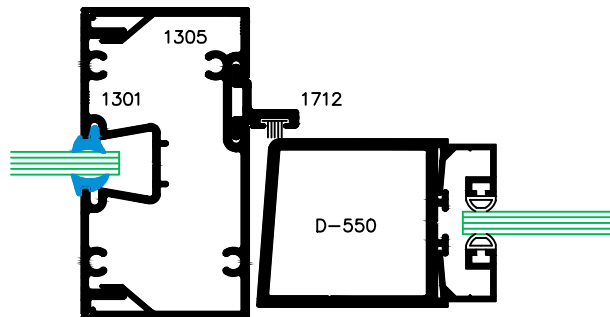
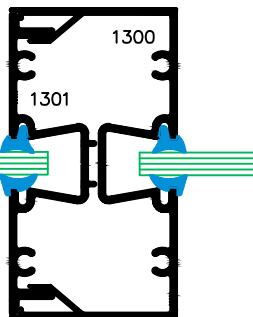
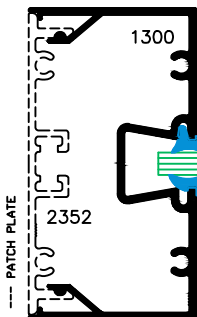
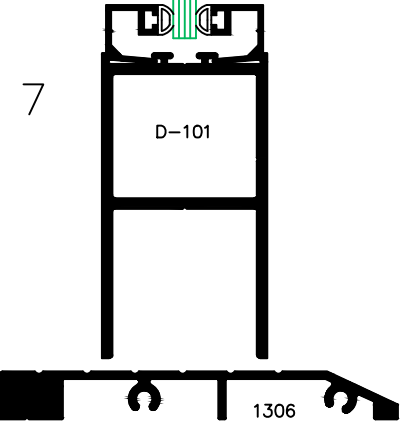
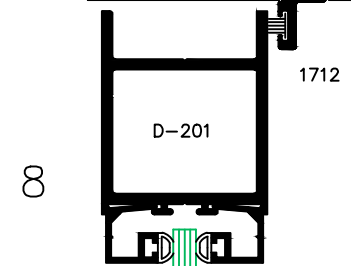
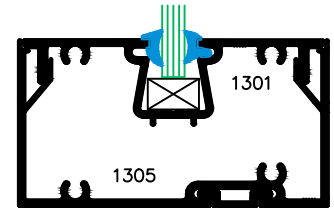
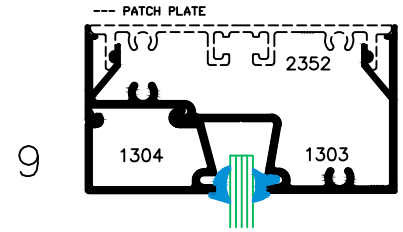
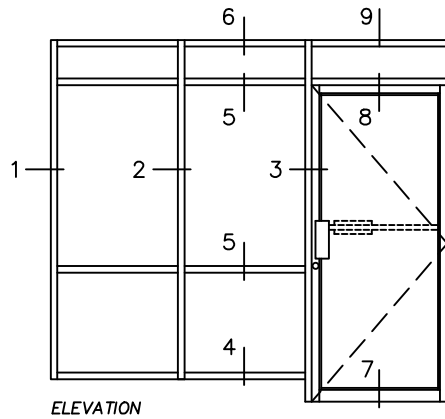
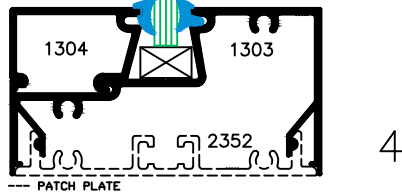
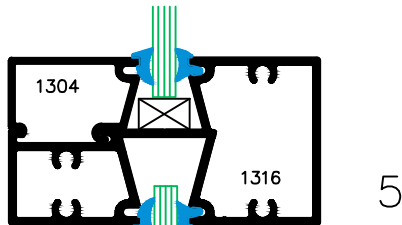
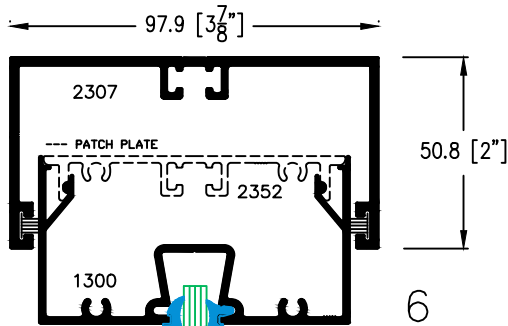

WIND LOAD CHART FOR 1300 SERIES - PART # 1300/1301

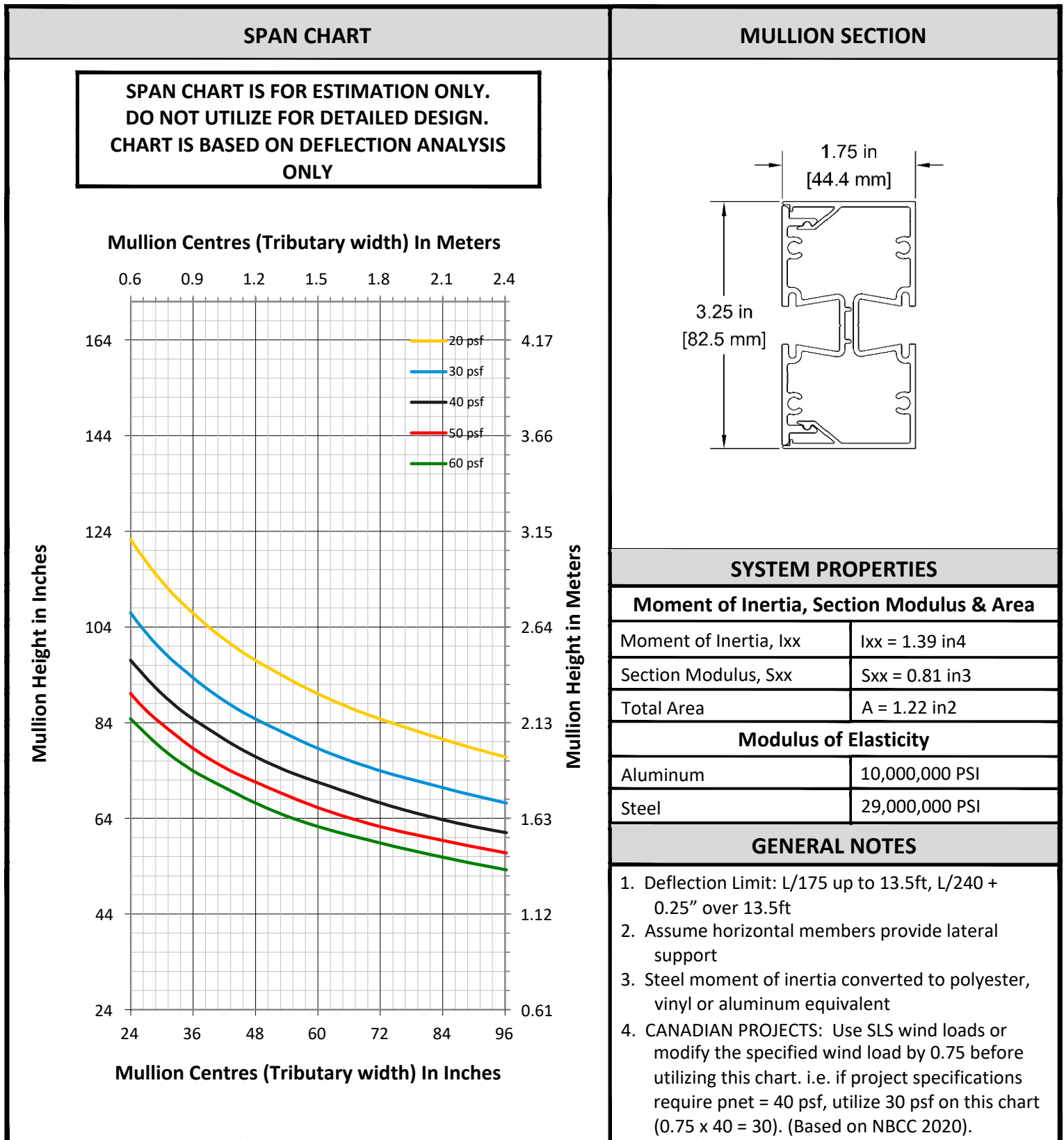

DEAD LOAD CHART FOR 1300 SERIES - PART # 1316

SPAN CHART

SPAN CHART IS FOR ESTIMATION ONLY.
DO NOT UTILIZE FOR DETAILED DESIGN.
CHART IS BASED ON DEFLECTION ANALYSIS
ONLY

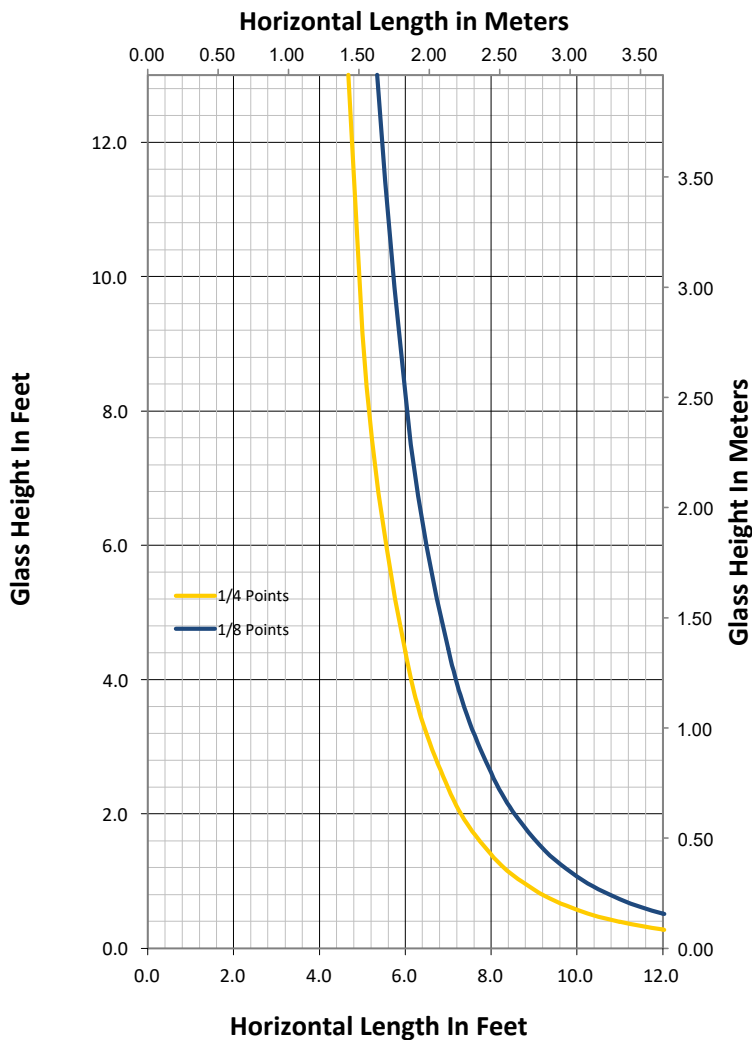

MULLION SECTION

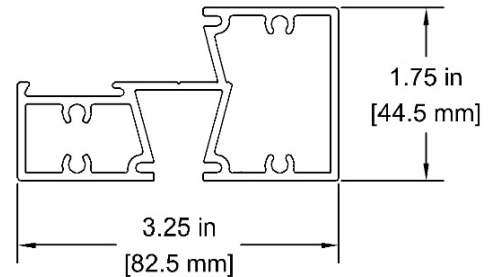

SYSTEM PROPERTIES

Moment of Inertia, Section Modulus & Area

Moment of Inertia, I_{yy}	$I_{yy} = 0.34 \text{ in}^4$
Section Modulus, S_{yy}	$S_{yy} = 0.33 \text{ in}^3$
Total Area	$A = 1.05 \text{ in}^2$

Modulus of Elasticity

Aluminum	10,000,000 PSI
Steel	29,000,000 PSI

GENERAL NOTES

1. Deflection Limit: 0.125" (3.2mm).
2. Charts are calculated assuming 6mm single pane glass.
3. Calculations are based on the position of the setting blocks being placed at 1/4 or 1/8 points.



**METRO
ALUMINUM**

Products Ltd.

2300 SERIES

DOUBLE GLAZING STOREFRONT SYSTEM
2" X 3 1/4" (50.8mm X 82.6mm)

C





**METRO
ALUMINUM**

Products Ltd.

2300 SERIES

DOUBLE GLAZING STOREFRONT SYSTEM
2" X 3 1/4" (50.8mm X 82.6mm)

**C
05**

COMPONENTS

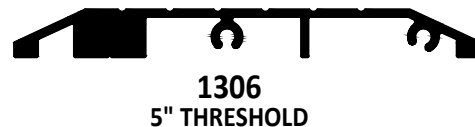
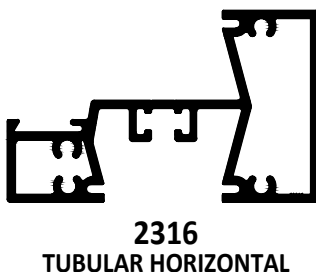
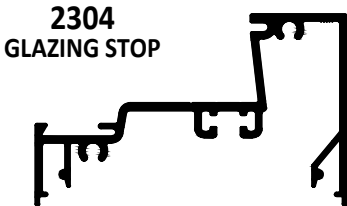
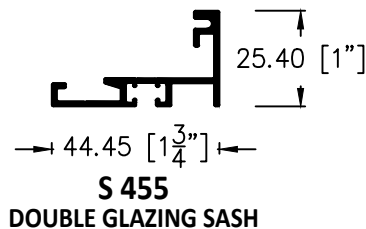
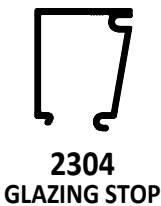
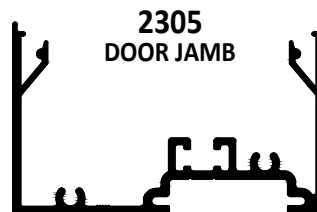
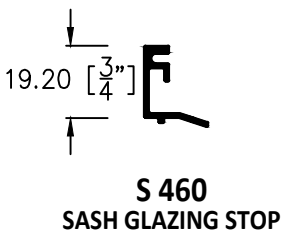
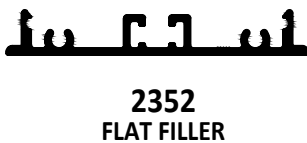
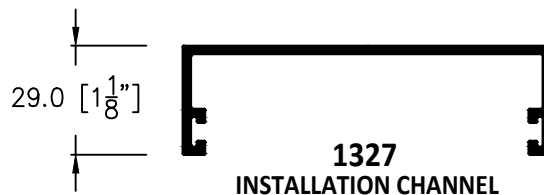
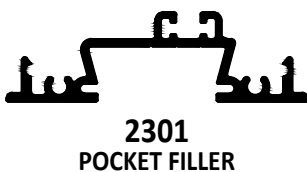
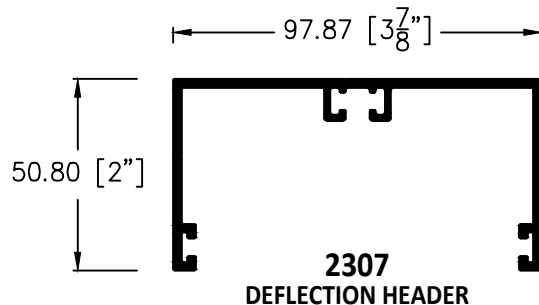
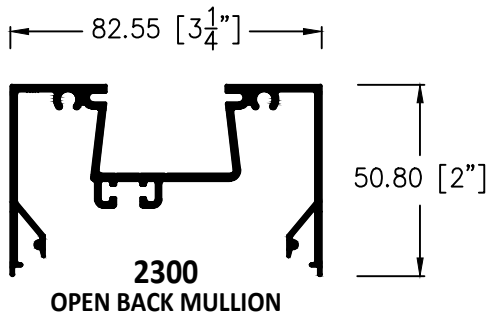



**METRO
ALUMINUM**
Products Ltd.

2300 SERIES
DOUBLE GLAZING STOREFRONT SYSTEM
2" X 3 1/4" (50.8mm X 82.6mm)

**C
06**

TYPICAL DETAILS

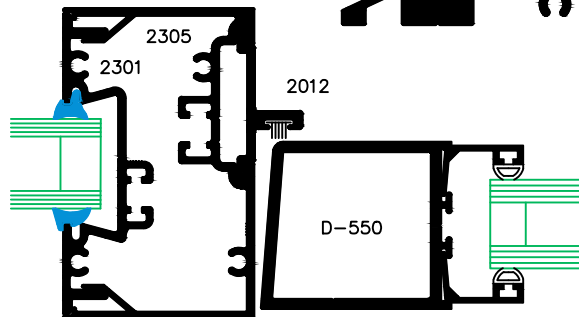
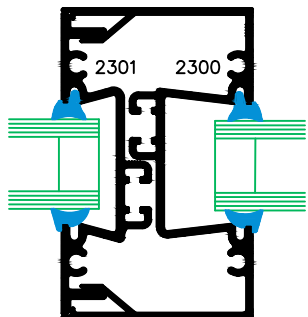
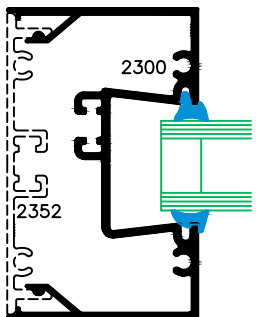
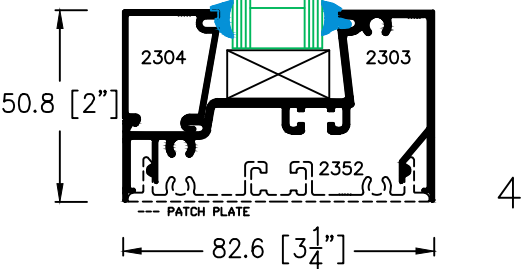
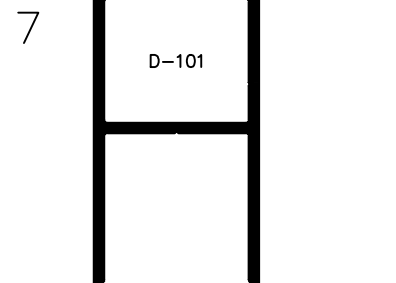
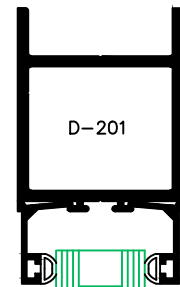
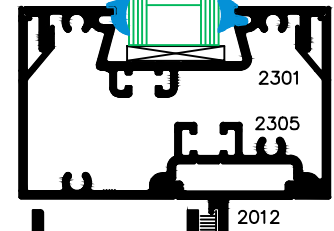
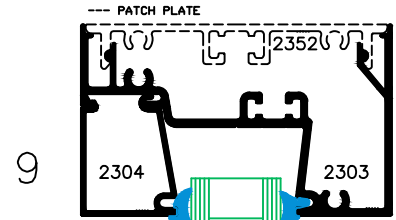
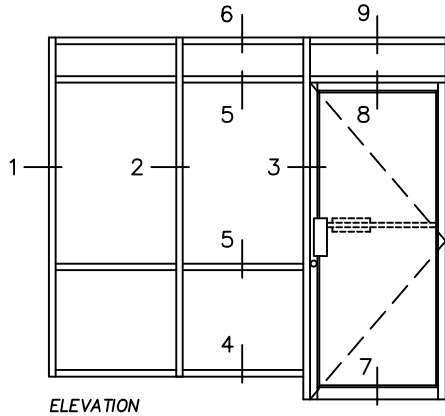
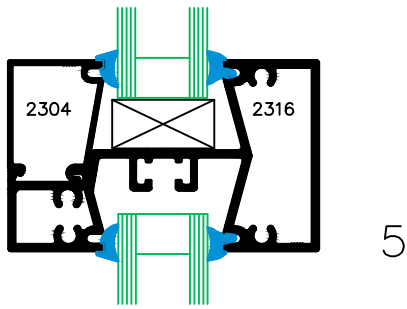
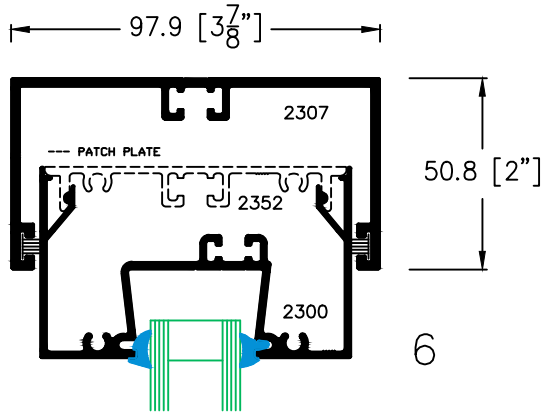

WIND LOAD CHART FOR 2300 SERIES - PART # 2300/2301

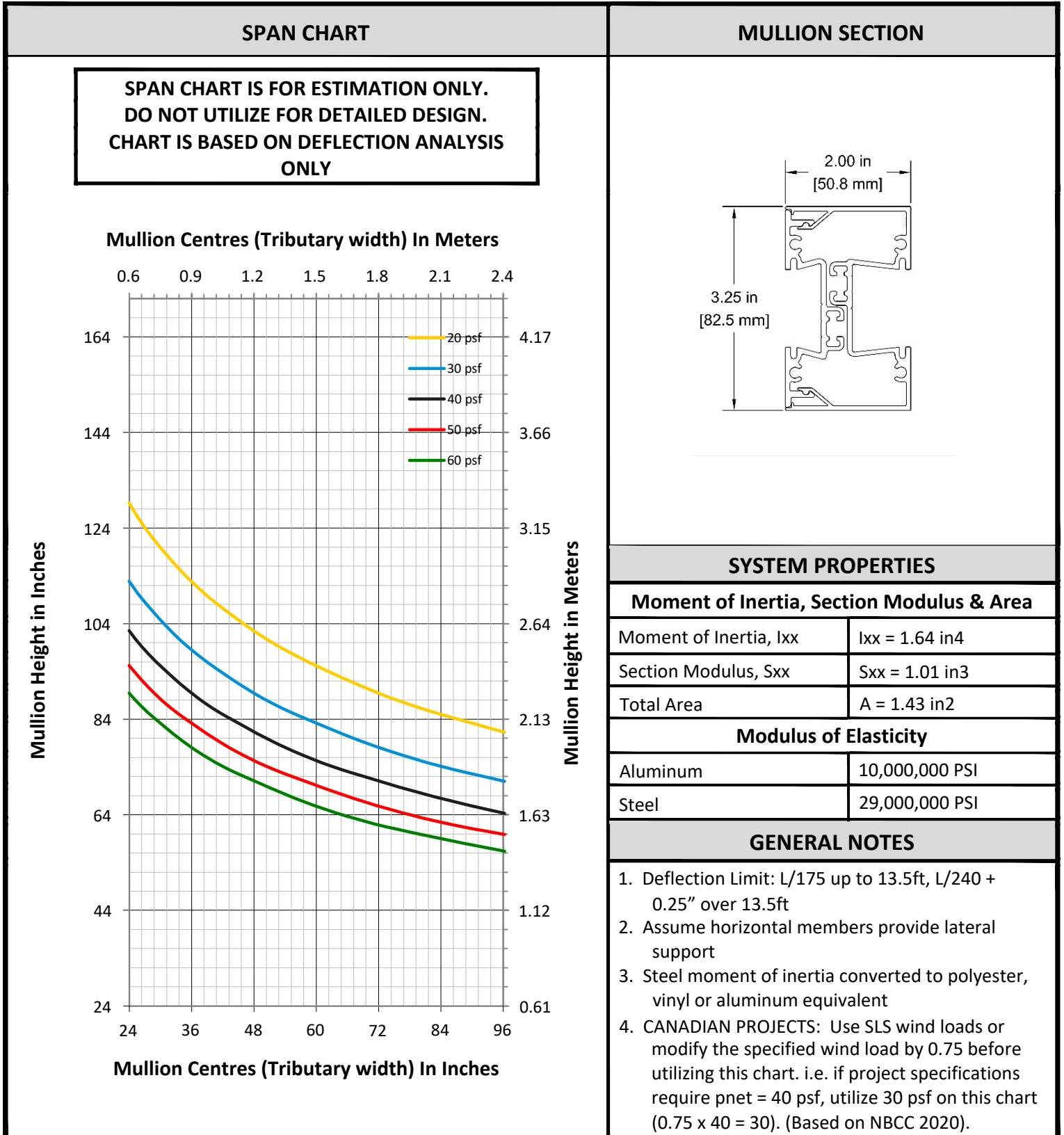

DEAD LOAD CHART FOR 2300 SERIES - PART # 2316

SPAN CHART

SPAN CHART IS FOR ESTIMATION ONLY.
DO NOT UTILIZE FOR DETAILED DESIGN.
CHART IS BASED ON DEFLECTION ANALYSIS
ONLY

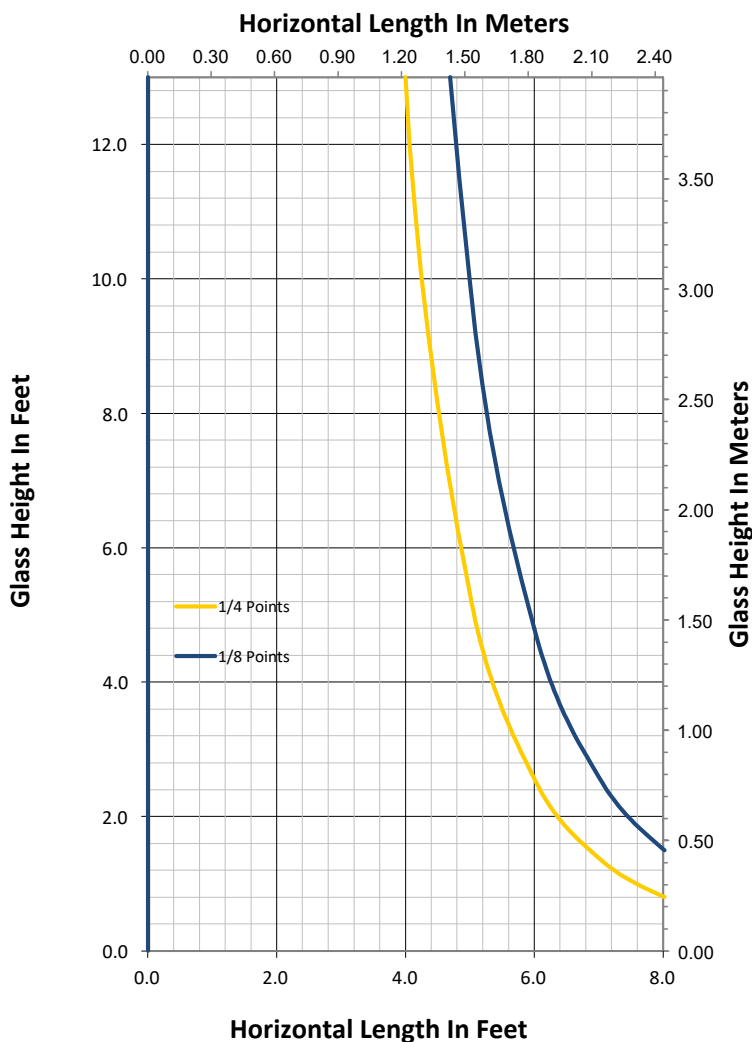

MULLION SECTION

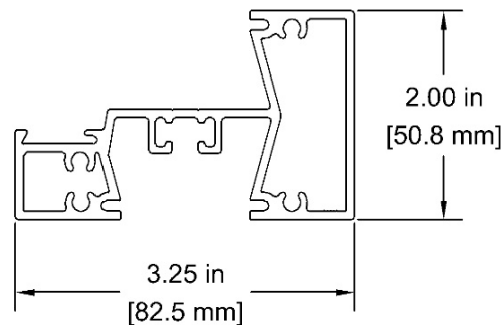

SYSTEM PROPERTIES

Moment of Inertia, Section Modulus & Area

Moment of Inertia, I_{yy}	$I_{yy} = 0.39 \text{ in}^4$
Section Modulus, S_{yy}	$S_{yy} = 0.33 \text{ in}^3$
Total Area	$A = 1.09 \text{ in}^2$

Modulus of Elasticity

Aluminum	10,000,000 PSI
Steel	29,000,000 PSI

GENERAL NOTES

Deflection Limit: 0.125" (3.2mm).
Charts are calculated assuming a 15/16" overall sealed unit (6mm/12mm spacer/6mm).
Calculations are based on the position of the setting blocks being placed at either 1/4 or 1/8 points.



**METRO
ALUMINUM**

Products Ltd.

2300T SERIES
THERMALLY BROKEN STOREFRONT SYSTEM
2" X 3 1/4" (50.8mm X 82.6mm)

C





COMPONENTS

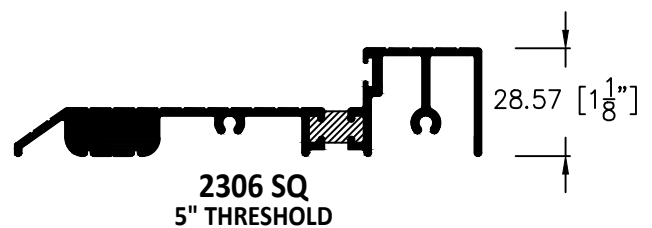
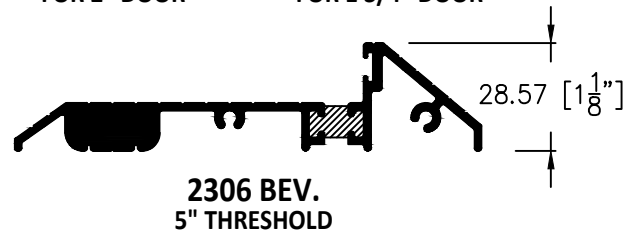
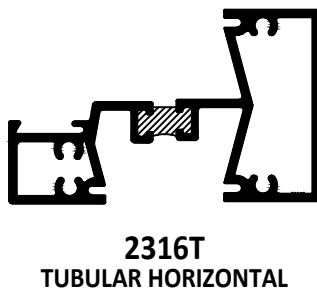
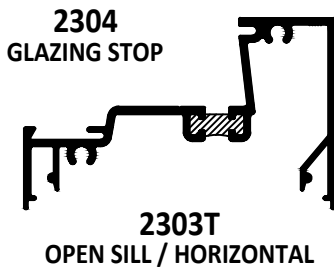
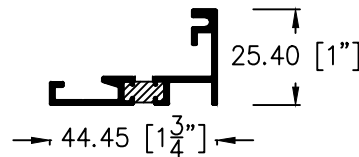
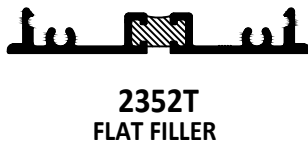
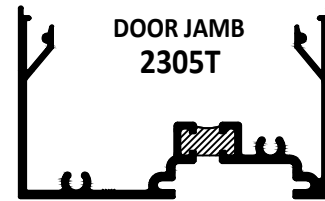
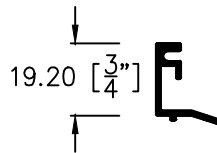
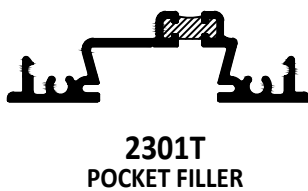
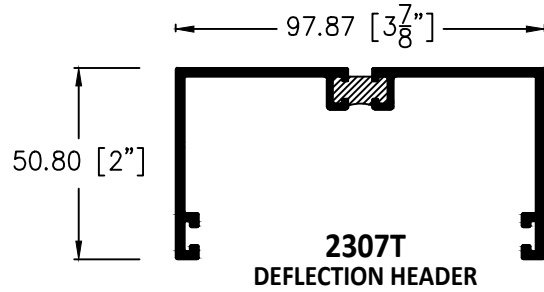
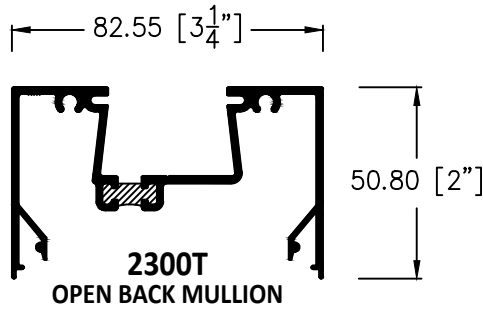



**METRO
ALUMINUM**
Products Ltd.

2300T SERIES

THERMALLY BROKEN STOREFRONT SYSTEM
2" X 3 1/4" (50.8mm X 82.6mm)

**C
09**

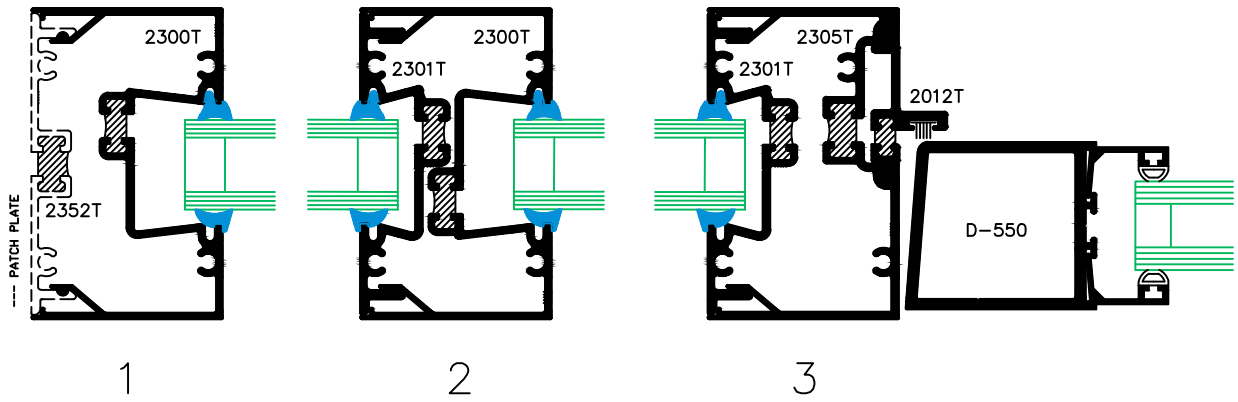
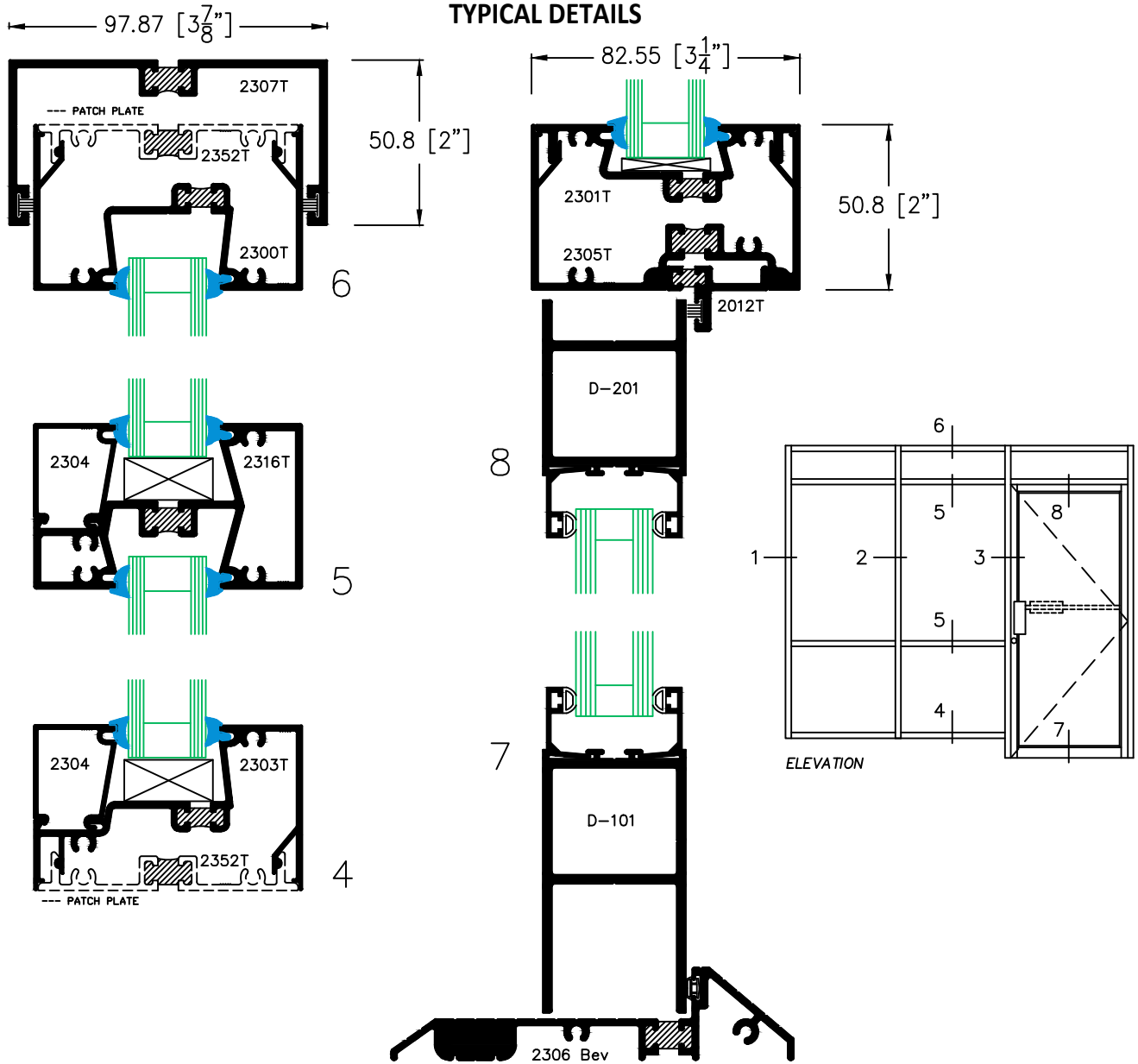

WIND LOAD CHART FOR 2300T SERIES - PART # 2300T/2301T

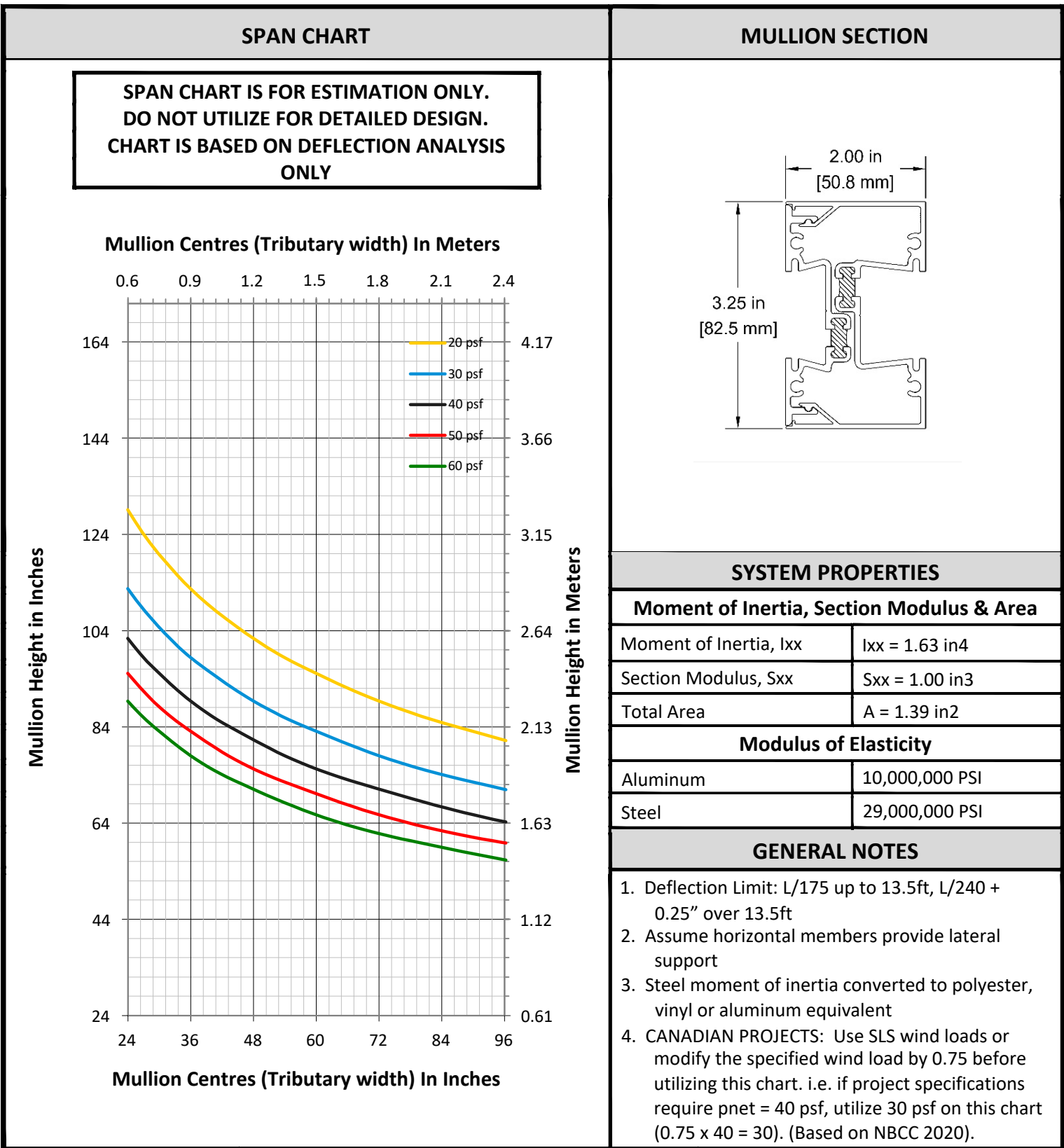

DEAD LOAD CHART FOR 2300T SERIES - PART # 2316T

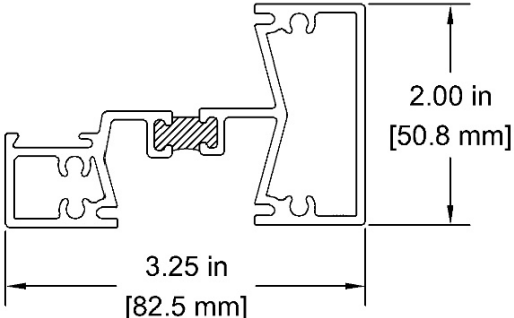
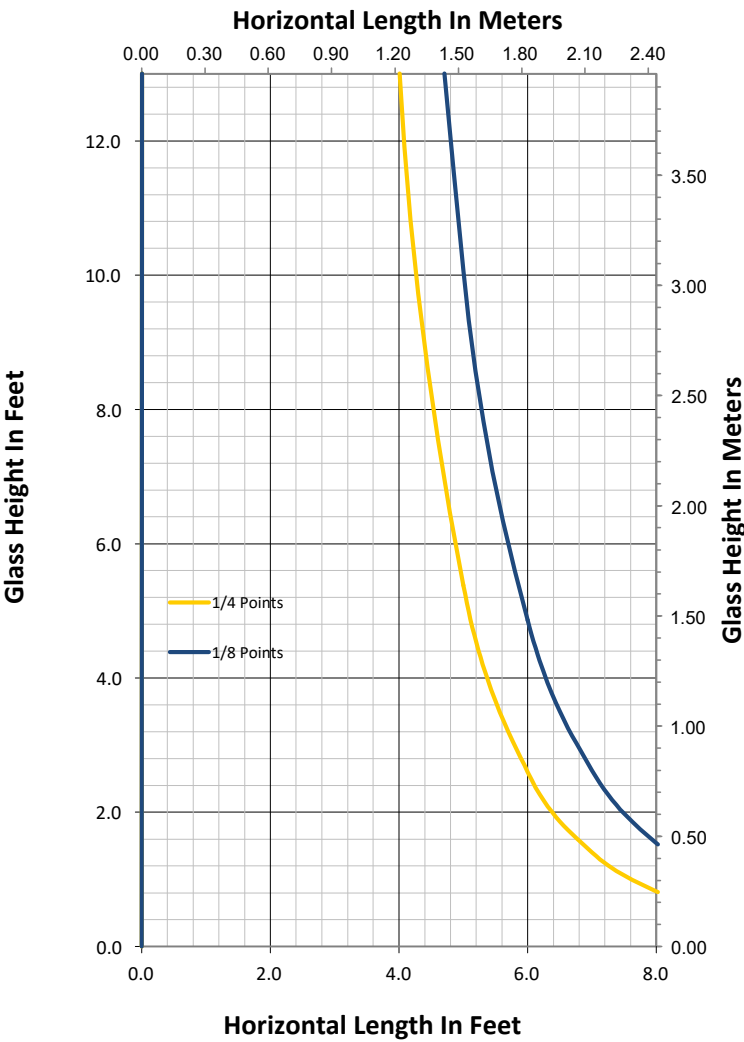
SPAN CHART	MULLION SECTION																				
<p>SPAN CHART IS FOR ESTIMATION ONLY. DO NOT UTILIZE FOR DETAILED DESIGN. CHART IS BASED ON DEFLECTION ANALYSIS ONLY</p>																					
	<table border="1" style="width: 100%; border-collapse: collapse;"> <thead> <tr style="background-color: #cccccc;"> <th colspan="2" style="text-align: center;">SYSTEM PROPERTIES</th> </tr> </thead> <tbody> <tr style="background-color: #cccccc;"> <th colspan="2" style="text-align: center;">Moment of Inertia, Section Modulus & Area</th> </tr> <tr> <td style="text-align: left;">Moment of Inertia, I_{yy}</td> <td style="text-align: right;">$I_{yy} = 0.40 \text{ in}^4$</td> </tr> <tr> <td style="text-align: left;">Section Modulus, S_{yy}</td> <td style="text-align: right;">$S_{yy} = 0.33 \text{ in}^3$</td> </tr> <tr> <td style="text-align: left;">Total Area</td> <td style="text-align: right;">$A = 1.07 \text{ in}^2$</td> </tr> <tr style="background-color: #cccccc;"> <th colspan="2" style="text-align: center;">Modulus of Elasticity</th> </tr> <tr> <td style="text-align: left;">Aluminum</td> <td style="text-align: right;">10,000,000 PSI</td> </tr> <tr> <td style="text-align: left;">Steel</td> <td style="text-align: right;">29,000,000 PSI</td> </tr> <tr style="background-color: #cccccc;"> <th colspan="2" style="text-align: center;">GENERAL NOTES</th> </tr> <tr> <td colspan="2" style="padding: 5px;"> Deflection Limit: 0.125" (3.2mm). Charts are calculated assuming a 15/16" overall sealed unit (6mm/12mm spacer/6mm). Calculations are based on the position of the setting blocks being placed at either 1/4 or 1/8 points. </td> </tr> </tbody> </table>	SYSTEM PROPERTIES		Moment of Inertia, Section Modulus & Area		Moment of Inertia, I_{yy}	$I_{yy} = 0.40 \text{ in}^4$	Section Modulus, S_{yy}	$S_{yy} = 0.33 \text{ in}^3$	Total Area	$A = 1.07 \text{ in}^2$	Modulus of Elasticity		Aluminum	10,000,000 PSI	Steel	29,000,000 PSI	GENERAL NOTES		Deflection Limit: 0.125" (3.2mm). Charts are calculated assuming a 15/16" overall sealed unit (6mm/12mm spacer/6mm). Calculations are based on the position of the setting blocks being placed at either 1/4 or 1/8 points.	
SYSTEM PROPERTIES																					
Moment of Inertia, Section Modulus & Area																					
Moment of Inertia, I_{yy}	$I_{yy} = 0.40 \text{ in}^4$																				
Section Modulus, S_{yy}	$S_{yy} = 0.33 \text{ in}^3$																				
Total Area	$A = 1.07 \text{ in}^2$																				
Modulus of Elasticity																					
Aluminum	10,000,000 PSI																				
Steel	29,000,000 PSI																				
GENERAL NOTES																					
Deflection Limit: 0.125" (3.2mm). Charts are calculated assuming a 15/16" overall sealed unit (6mm/12mm spacer/6mm). Calculations are based on the position of the setting blocks being placed at either 1/4 or 1/8 points.																					



**METRO
ALUMINUM**

Products Ltd.

1750 SERIES

SINGLE GLAZING STOREFRONT SYSTEM
1 3/4" X 4 1/2" (44.5mm X 114.3mm)

C





**METRO
ALUMINUM**

Products Ltd.

1750 SERIES

SINGLE GLAZING STOREFRONT SYSTEM
1 3/4" X 4 1/2" (44.5mm X 114.3mm)

**C
11**

COMPONENTS

129.6 [5 1/8"]

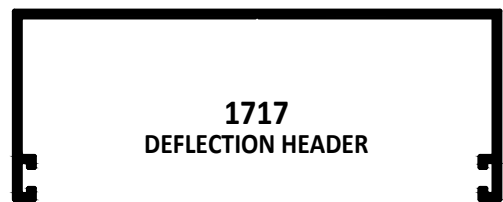

1717
DEFLECTION HEADER

50.8 [2"]



1727
INSTALLATION CHANNEL

29.0 [1 1/8"]



5134
FACE GASKET

5130
BACK GASKET



1750
OPEN BACK MULLION



1751
DEEP POCKET FILLER



1752
FLAT POCKET FILLER

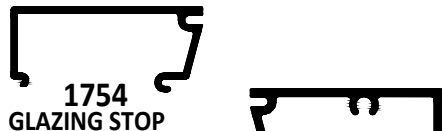

1754
GLAZING STOP



1753
OPEN SILL/ HORIZONTAL MULLION

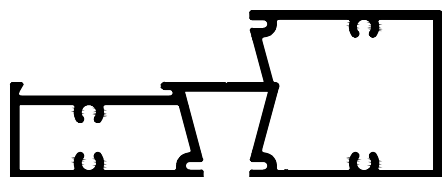

1716
TUBULAR SILL/ HORIZONTAL MULLION

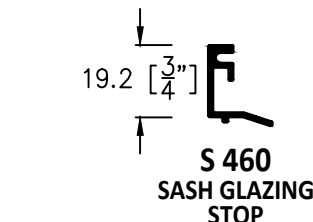

S 460
SASH GLAZING STOP

5082
SIDELITE BASE/ UPPER

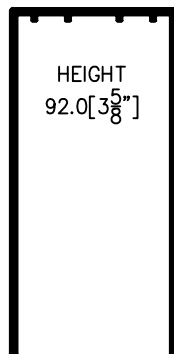

HEIGHT
92.0 [3 5/8"]

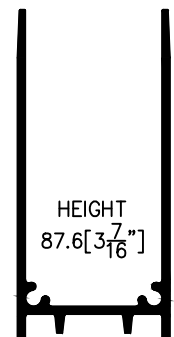

HEIGHT
87.6 [3 7/16"]

5081
SIDELITE BASE/ LOWER



1713
1/2" POCKET FILLER

1712
DOOR STOP

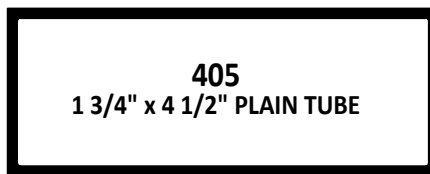

405
1 3/4" x 4 1/2" PLAIN TUBE

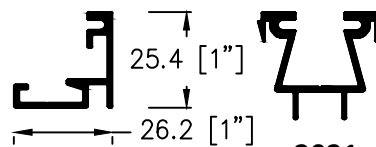

S 450
SINGLE GLAZING SASH

2021
SINGLE GLAZING ADAPTER

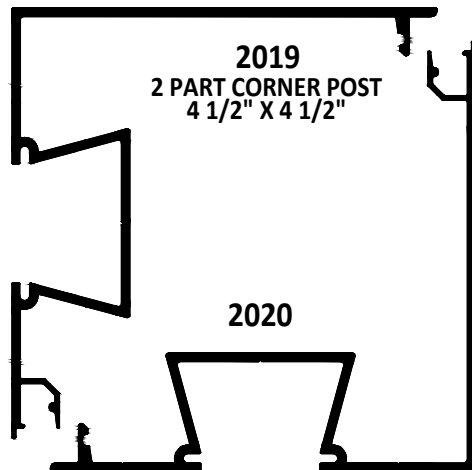

2019
2 PART CORNER POST
4 1/2" X 4 1/2"

2020



1506
6" THRESHOLD

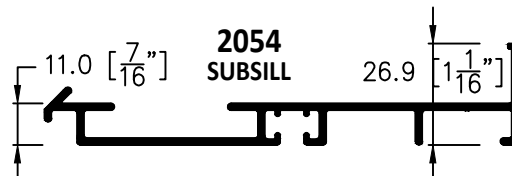

2054
SUBSILL



**METRO
ALUMINUM**

Products Ltd.

1750 SERIES

SINGLE GLAZING STOREFRONT SYSTEM
1 3/4" X 4 1/2" (44.5mm X 114.3mm)

**C
12**

TYPICAL DETAILS

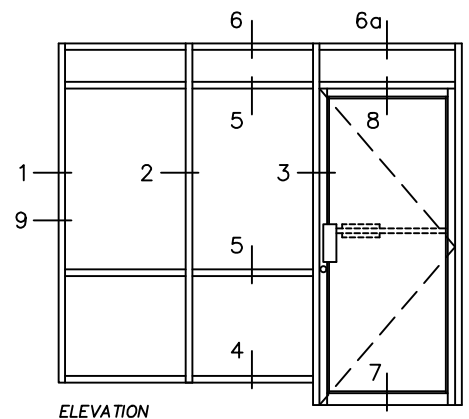
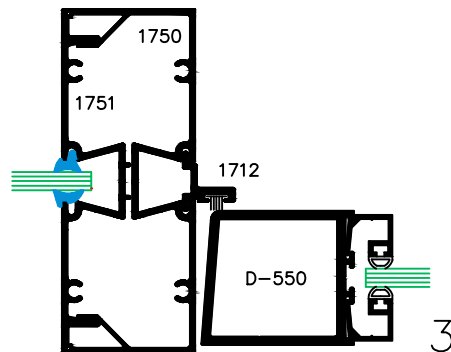
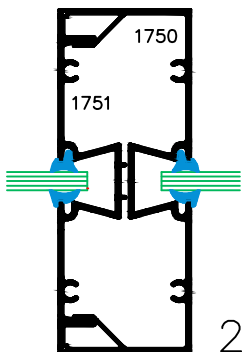
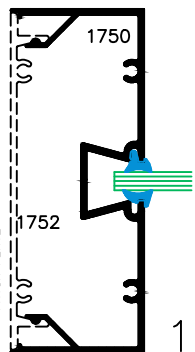
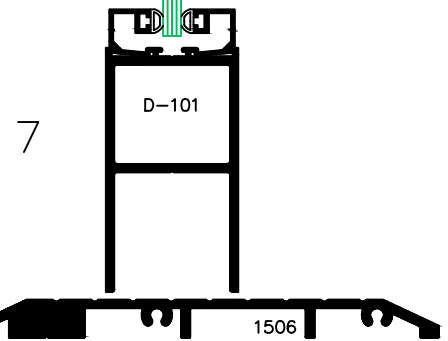
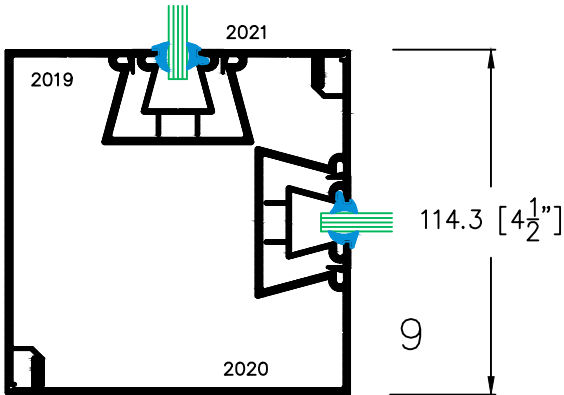
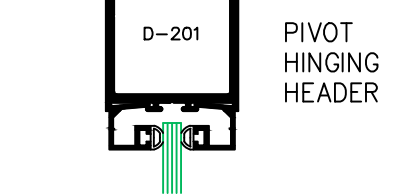
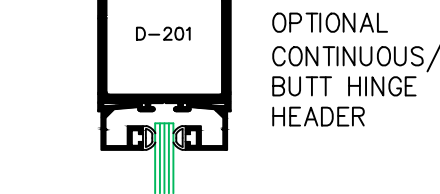
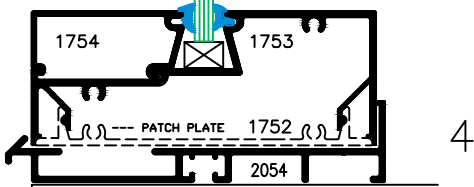
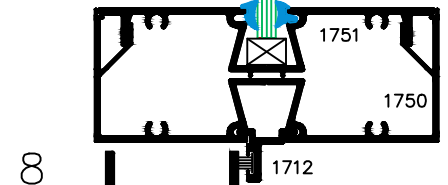
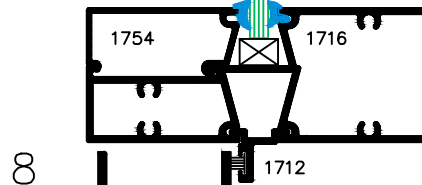
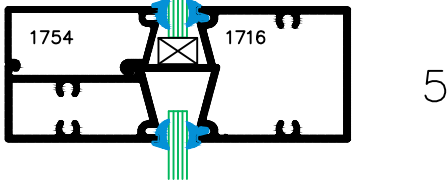
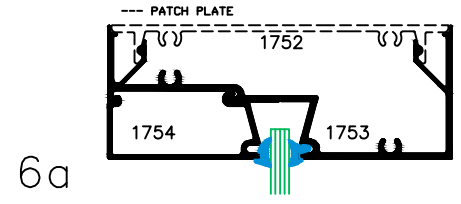
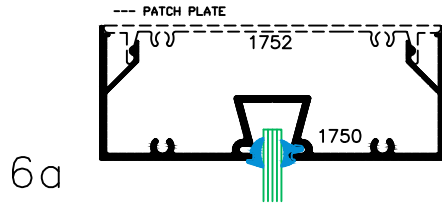
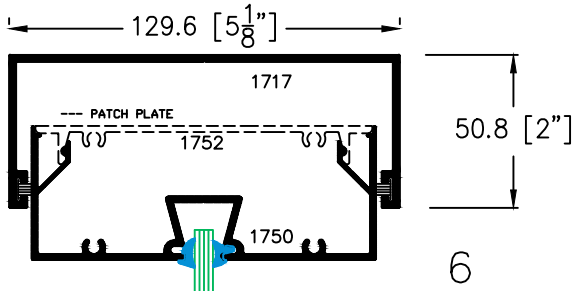

WIND LOAD CHART FOR 1750 SERIES - PART # 1750/1751

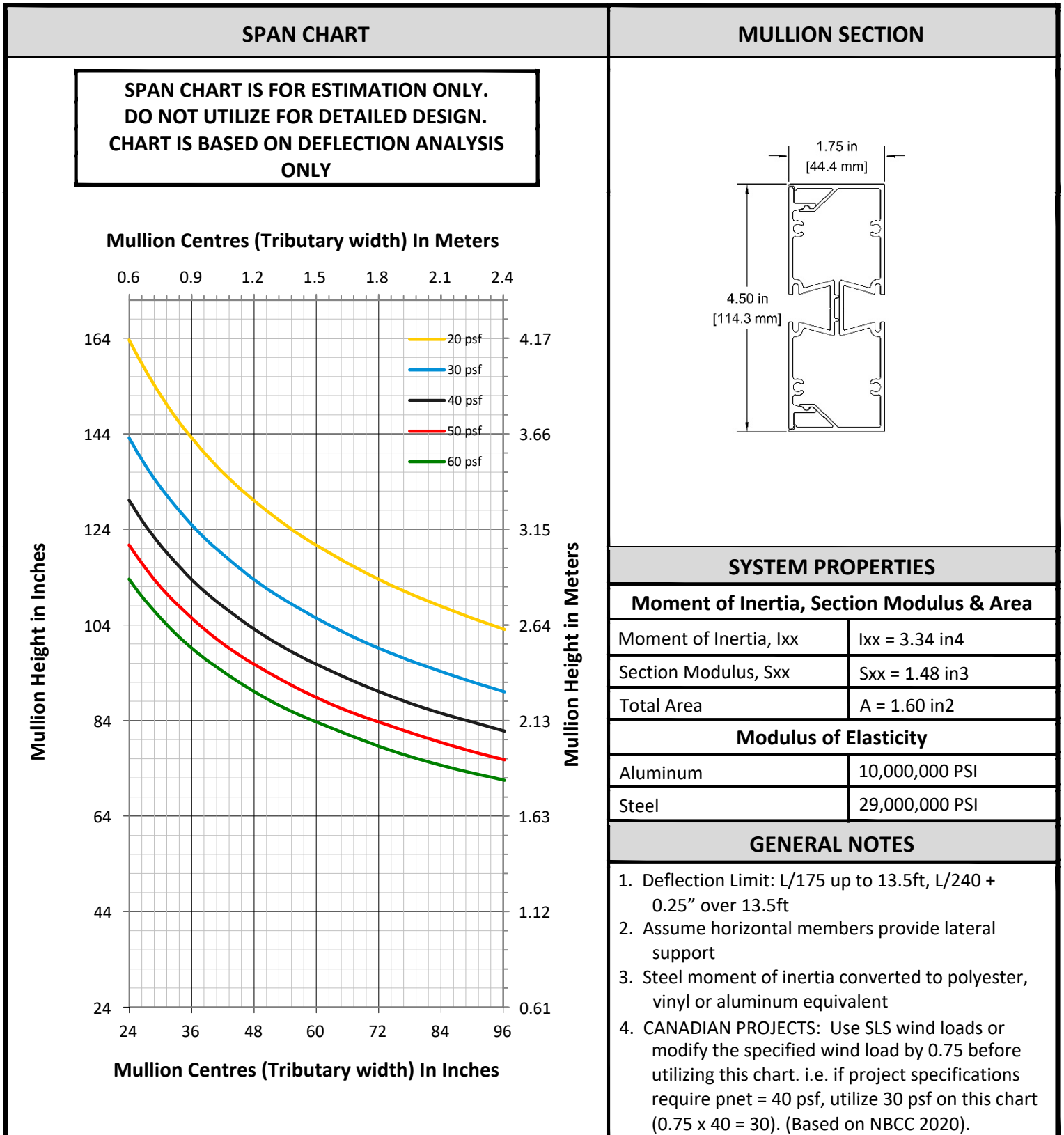

DEAD LOAD CHART FOR 1750 SERIES - PART # 1716

SPAN CHART

SPAN CHART IS FOR ESTIMATION ONLY.
DO NOT UTILIZE FOR DETAILED DESIGN.
CHART IS BASED ON DEFLECTION ANALYSIS
ONLY

MULLION SECTION

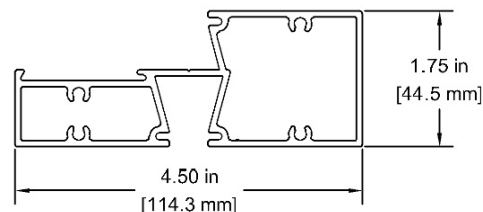

SYSTEM PROPERTIES

Moment of Inertia, Section Modulus & Area

Moment of Inertia, I_{yy}	$I_{yy} = 0.44 \text{ in}^4$
Section Modulus, S_{yy}	$S_{yy} = 0.42 \text{ in}^3$
Total Area	$A = 1.25 \text{ in}^2$

Modulus of Elasticity

Aluminum	10,000,000 PSI
Steel	29,000,000 PSI

GENERAL NOTES

1. Deflection Limit: 0.125" (3.2mm).
2. Charts are calculated assuming 6mm single pane glass.
3. Calculations are based on the position of the setting blocks being placed at 1/4 or 1/8 points.

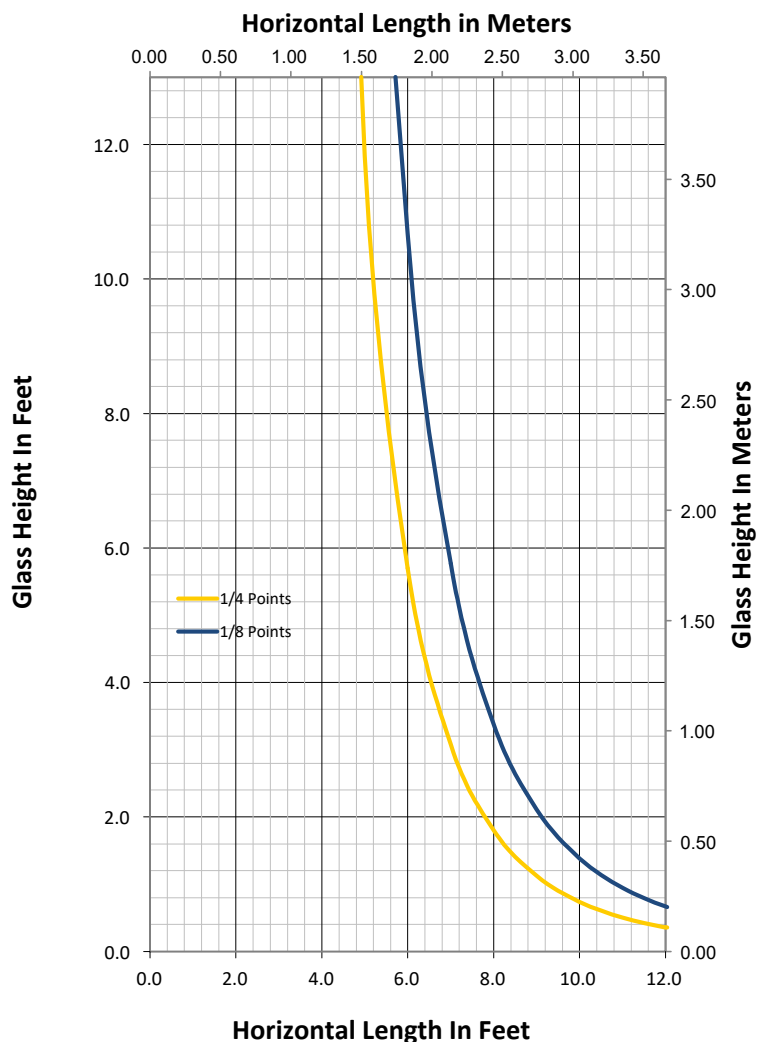



**METRO
ALUMINUM**

Products Ltd.

2050 SERIES

THERMALLY BROKEN STOREFRONT SYSTEM
2" X 4 1/2" (50.8mm X 114.3mm)

C





**METRO
ALUMINUM**

Products Ltd.

2050 SERIES

THERMALLY BROKEN STOREFRONT SYSTEM
2" X 4 1/2" (50.8mm X 114.3mm)

**C
14**

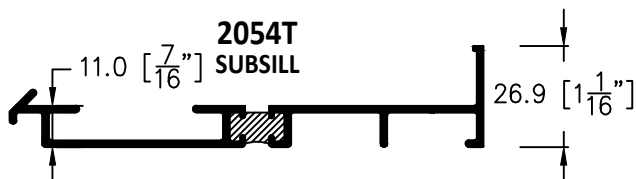
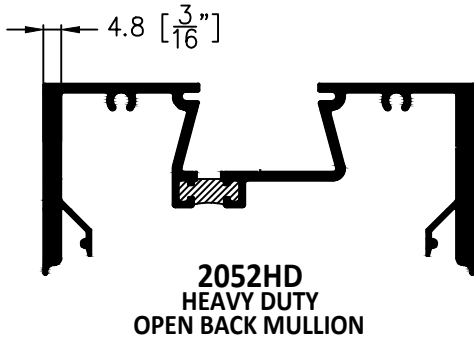
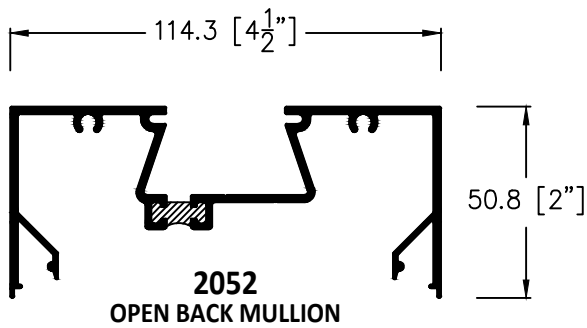
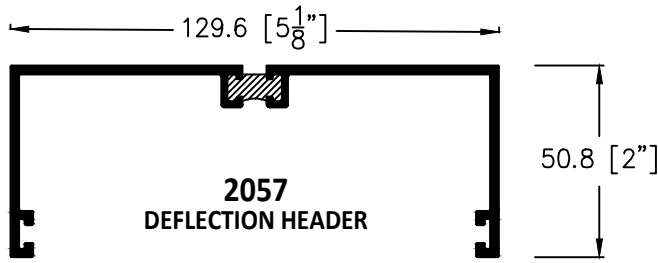

COMPONENTS

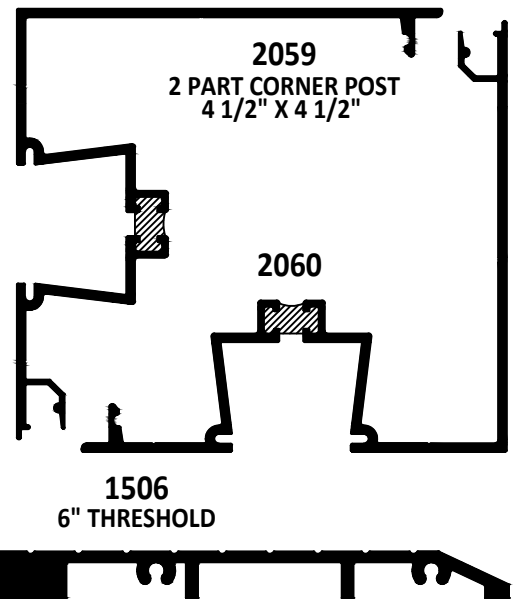
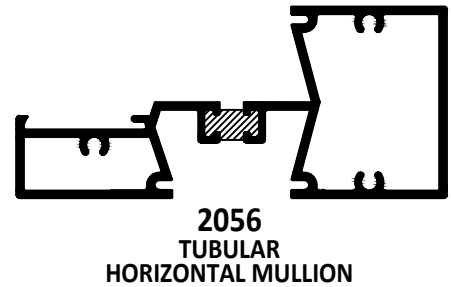
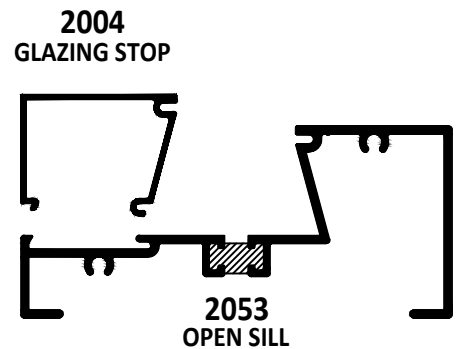
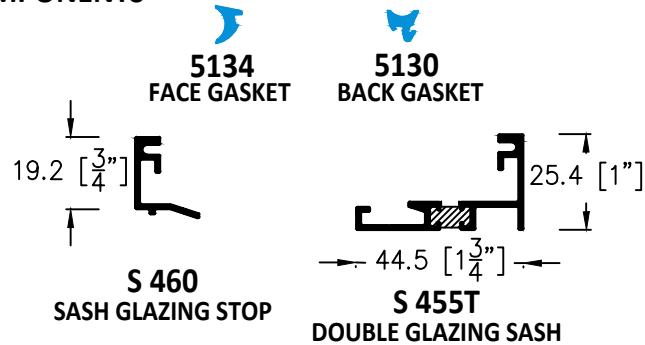



**METRO
ALUMINUM**
Products Ltd.

2050 SERIES

THERMALLY BROKEN STOREFRONT SYSTEM
2" X 4 1/2" (50.8mm X 114.3mm)

**C
15**

TYPICAL DETAILS

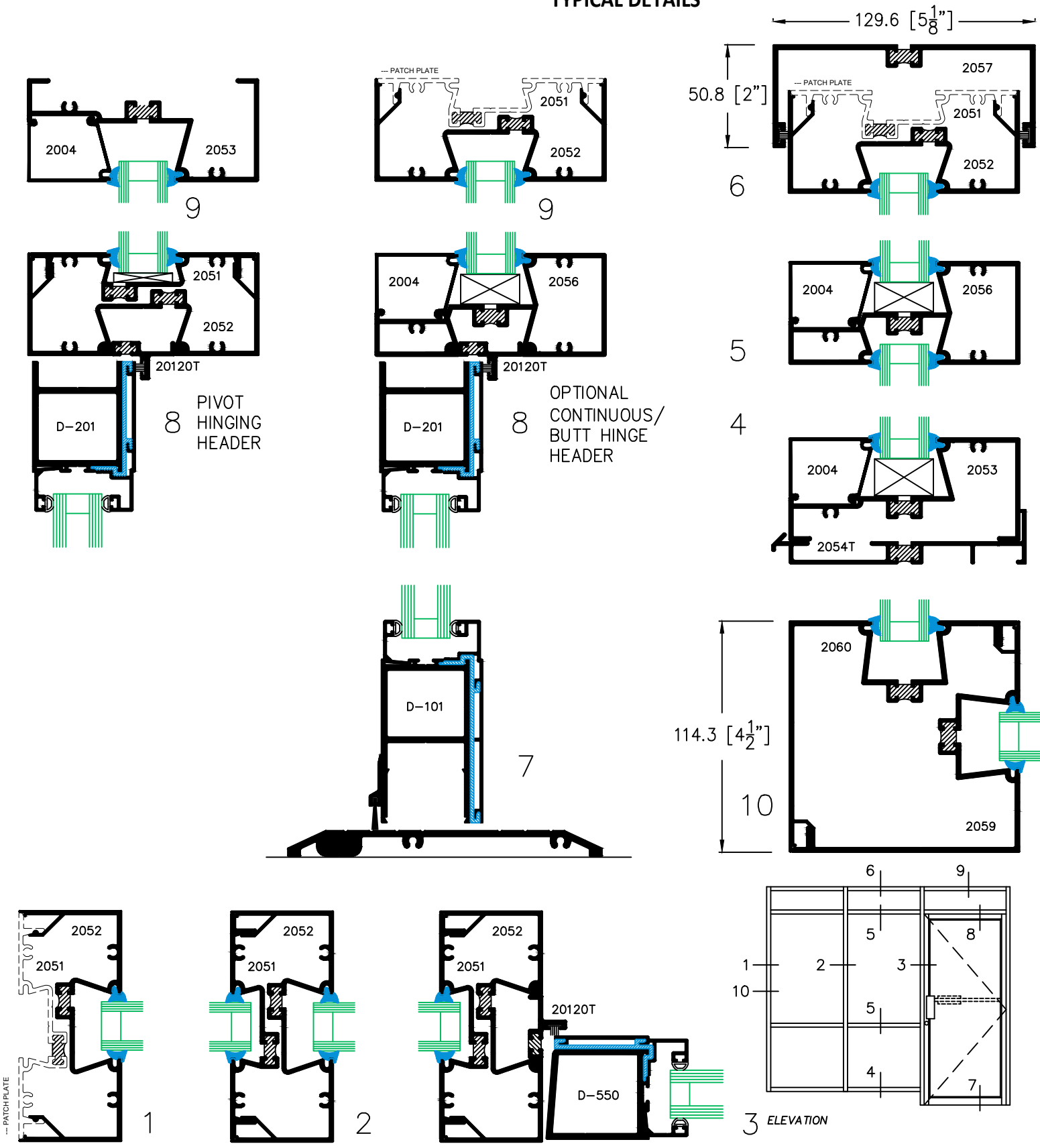

WIND LOAD CHART FOR 2050 SERIES - PART # 2052/2051

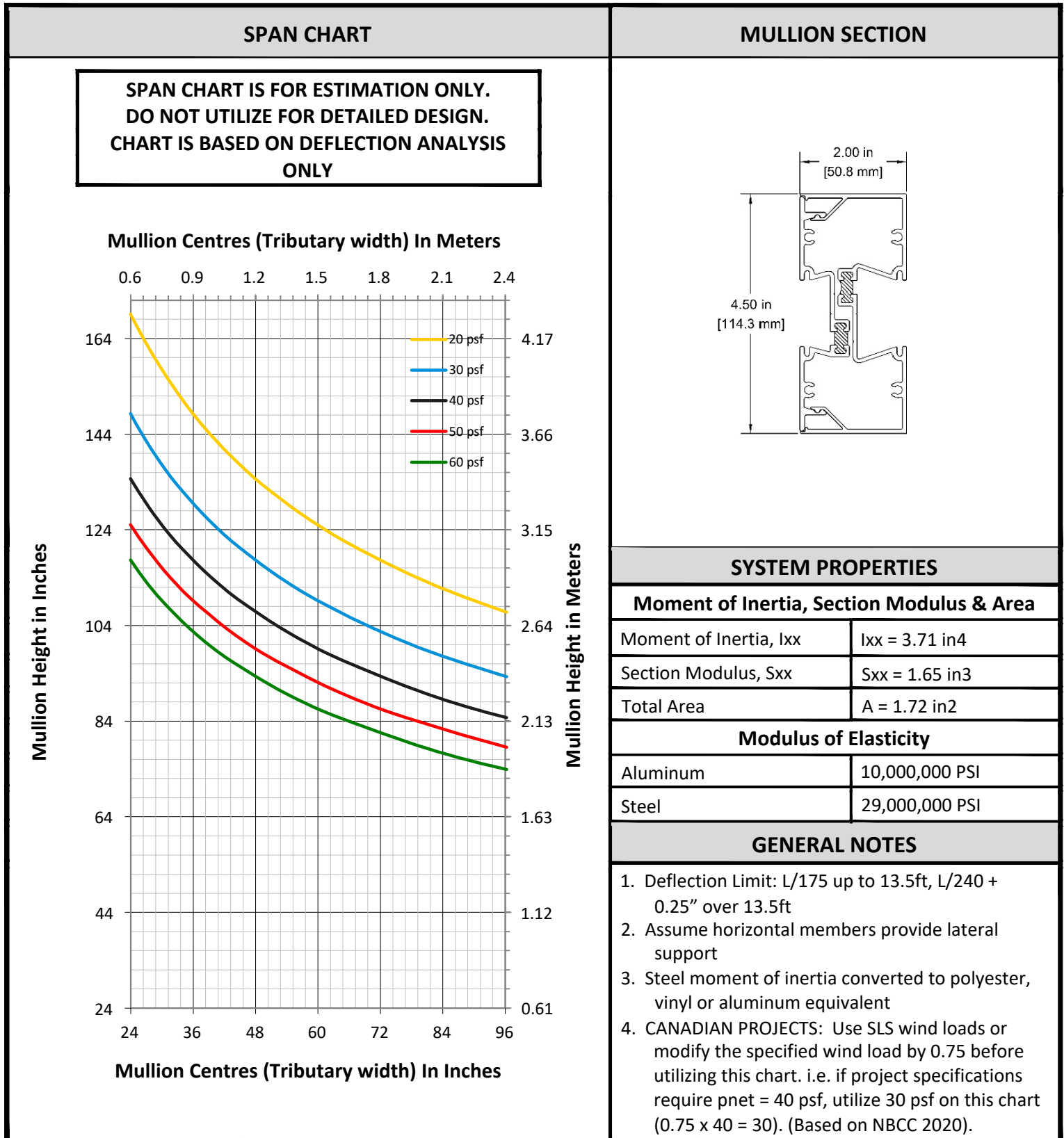

WIND LOAD CHART FOR 2050 SERIES - PART # 2052HD/2051

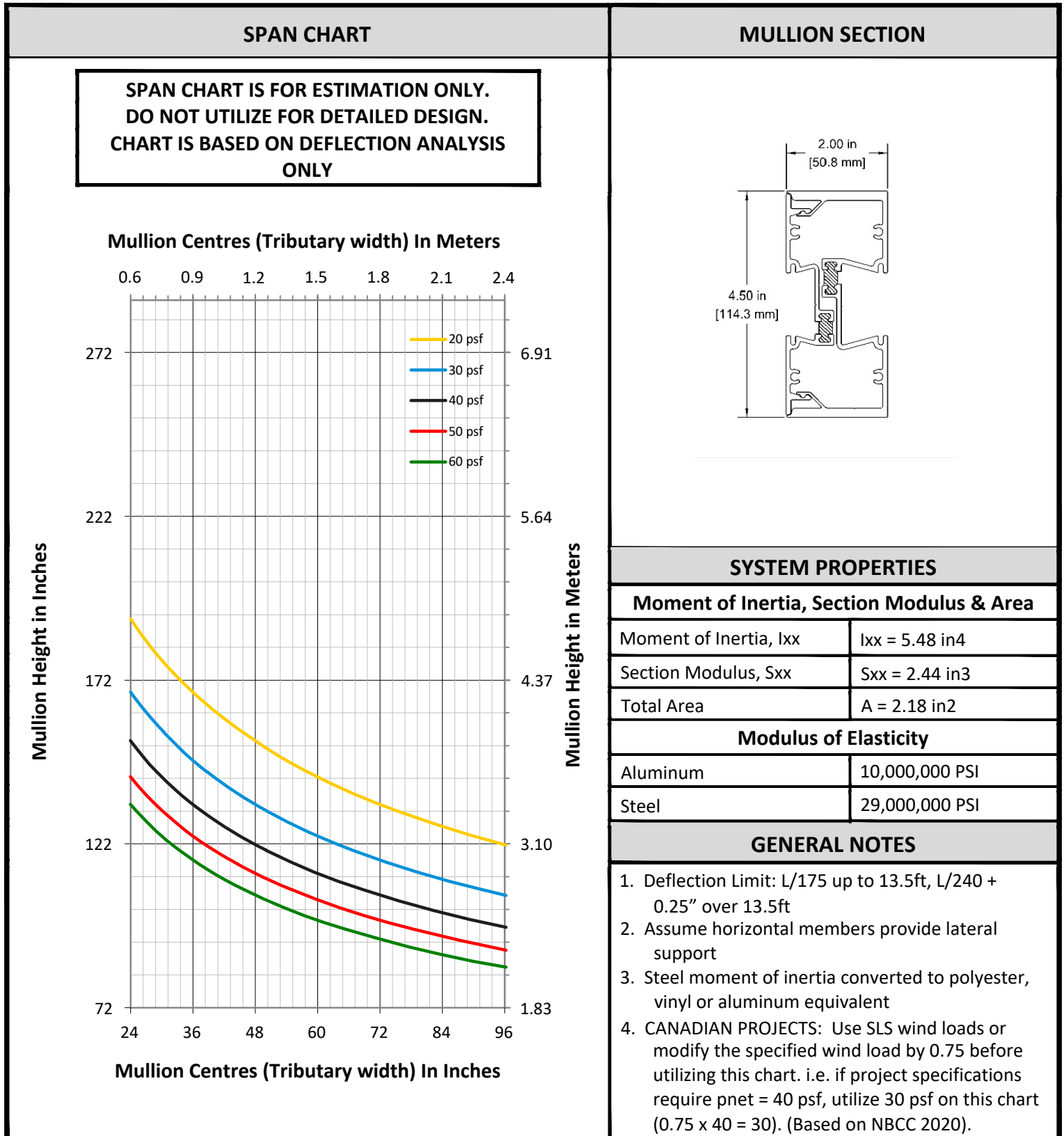

DEAD LOAD CHART FOR 2050 SERIES - PART # 2056

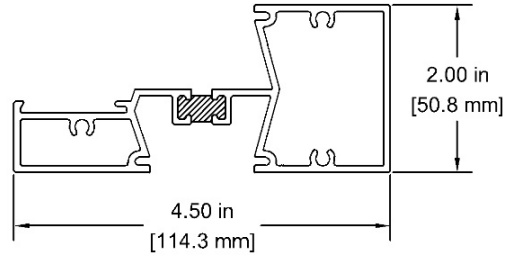
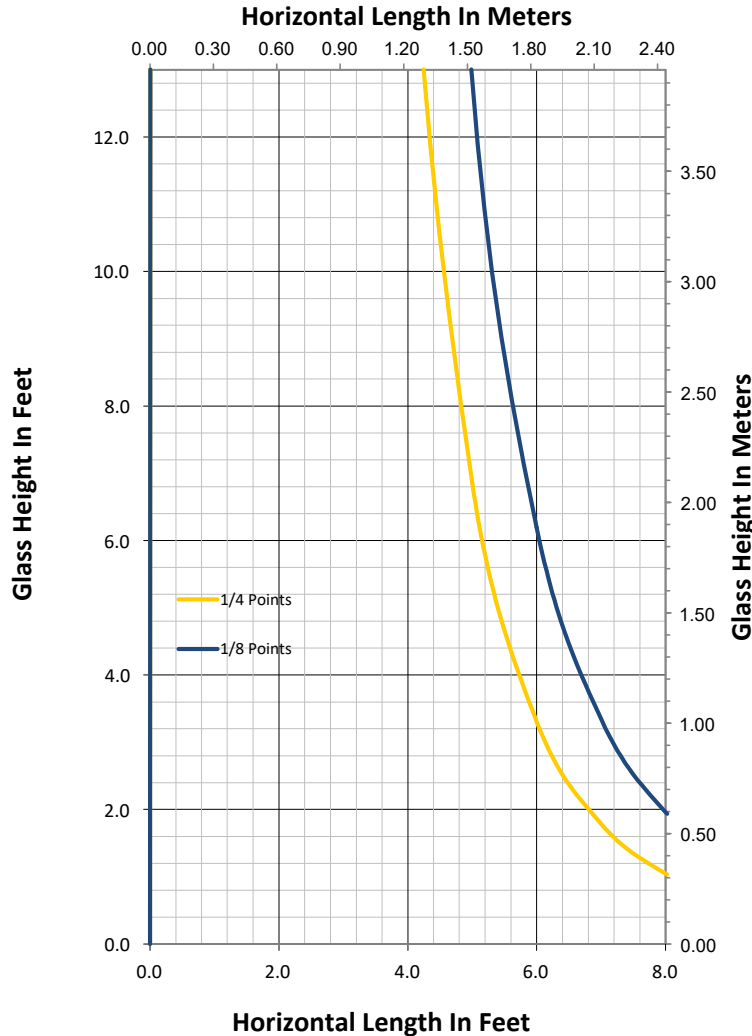
SPAN CHART	MULLION SECTION																				
<p>SPAN CHART IS FOR ESTIMATION ONLY. DO NOT UTILIZE FOR DETAILED DESIGN. CHART IS BASED ON DEFLECTION ANALYSIS ONLY</p>																					
	<table border="1" style="width: 100%; border-collapse: collapse;"> <thead> <tr style="background-color: #cccccc;"> <th colspan="2" style="text-align: center;">SYSTEM PROPERTIES</th> </tr> </thead> <tbody> <tr style="background-color: #cccccc;"> <th colspan="2" style="text-align: center;">Moment of Inertia, Section Modulus & Area</th> </tr> <tr> <td style="text-align: left;">Moment of Inertia, I_{yy}</td> <td>I_{yy} = 0.51 in⁴</td> </tr> <tr> <td style="text-align: left;">Section Modulus, S_{yy}</td> <td>S_{yy} = 0.42 in³</td> </tr> <tr> <td style="text-align: left;">Total Area</td> <td>A = 1.24 in²</td> </tr> <tr style="background-color: #cccccc;"> <th colspan="2" style="text-align: center;">Modulus of Elasticity</th> </tr> <tr> <td style="text-align: left;">Aluminum</td> <td>10,000,000 PSI</td> </tr> <tr> <td style="text-align: left;">Steel</td> <td>29,000,000 PSI</td> </tr> <tr style="background-color: #cccccc;"> <th colspan="2" style="text-align: center;">GENERAL NOTES</th> </tr> <tr> <td colspan="2"> <p>Deflection Limit: 0.125" (3.2mm). Charts are calculated assuming a 15/16" overall sealed unit (6mm/12mm spacer/6mm). Calculations are based on the position of the setting blocks being placed at either 1/4 or 1/8 points.</p> </td> </tr> </tbody> </table>	SYSTEM PROPERTIES		Moment of Inertia, Section Modulus & Area		Moment of Inertia, I _{yy}	I _{yy} = 0.51 in ⁴	Section Modulus, S _{yy}	S _{yy} = 0.42 in ³	Total Area	A = 1.24 in ²	Modulus of Elasticity		Aluminum	10,000,000 PSI	Steel	29,000,000 PSI	GENERAL NOTES		<p>Deflection Limit: 0.125" (3.2mm). Charts are calculated assuming a 15/16" overall sealed unit (6mm/12mm spacer/6mm). Calculations are based on the position of the setting blocks being placed at either 1/4 or 1/8 points.</p>	
SYSTEM PROPERTIES																					
Moment of Inertia, Section Modulus & Area																					
Moment of Inertia, I _{yy}	I _{yy} = 0.51 in ⁴																				
Section Modulus, S _{yy}	S _{yy} = 0.42 in ³																				
Total Area	A = 1.24 in ²																				
Modulus of Elasticity																					
Aluminum	10,000,000 PSI																				
Steel	29,000,000 PSI																				
GENERAL NOTES																					
<p>Deflection Limit: 0.125" (3.2mm). Charts are calculated assuming a 15/16" overall sealed unit (6mm/12mm spacer/6mm). Calculations are based on the position of the setting blocks being placed at either 1/4 or 1/8 points.</p>																					



**METRO
ALUMINUM**

Products Ltd.

2100T SERIES

THERMALLY BROKEN STOREFRONT SYSTEM
2" X 4 1/2" (50.8mm X 114.3mm)

C





**METRO
ALUMINUM**
Products Ltd.

2100T SERIES

THERMALLY BROKEN STOREFRONT SYSTEM
2" X 4 1/2" (50.8mm X 114.3mm)

**C
17**

COMPONENTS

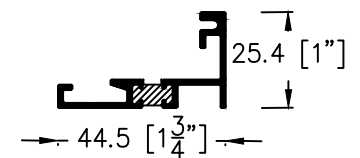
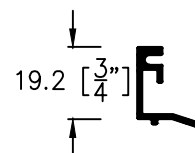
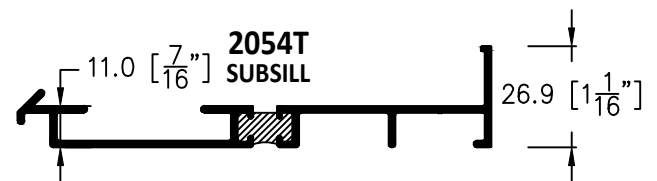
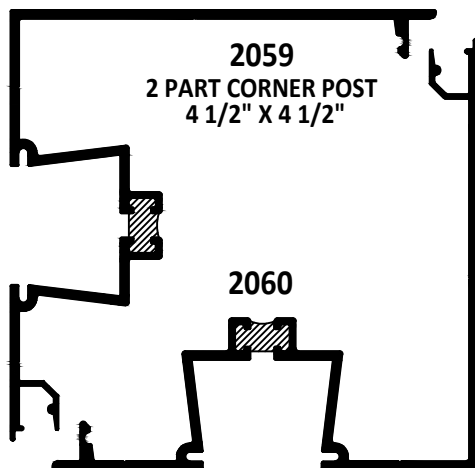
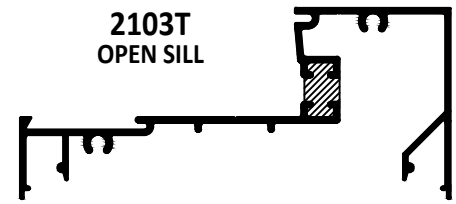
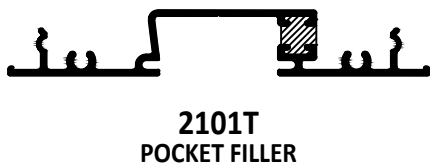
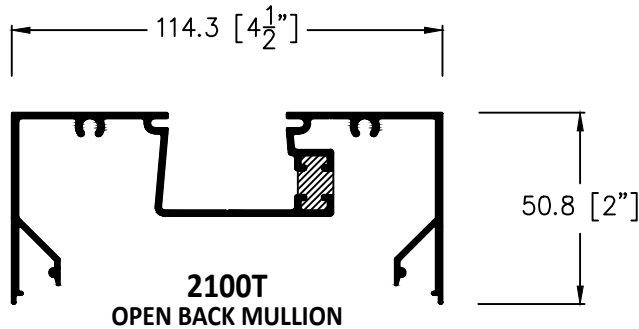
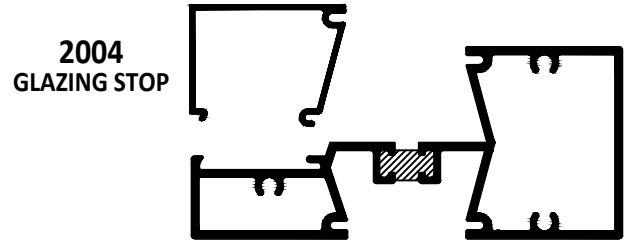
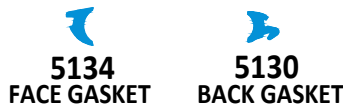
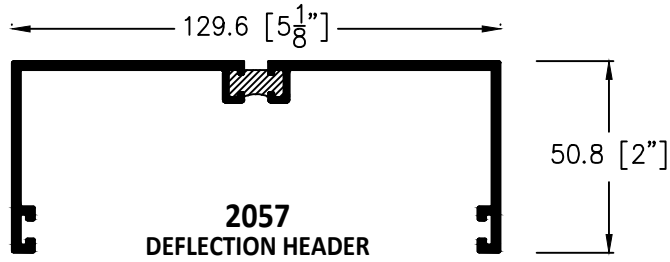



**METRO
ALUMINUM**
Products Ltd.

2100T SERIES

THERMALLY BROKEN STOREFRONT SYSTEM
2" X 4 1/2" (50.8mm X 114.3mm)

**C
18**

TYPICAL DETAILS

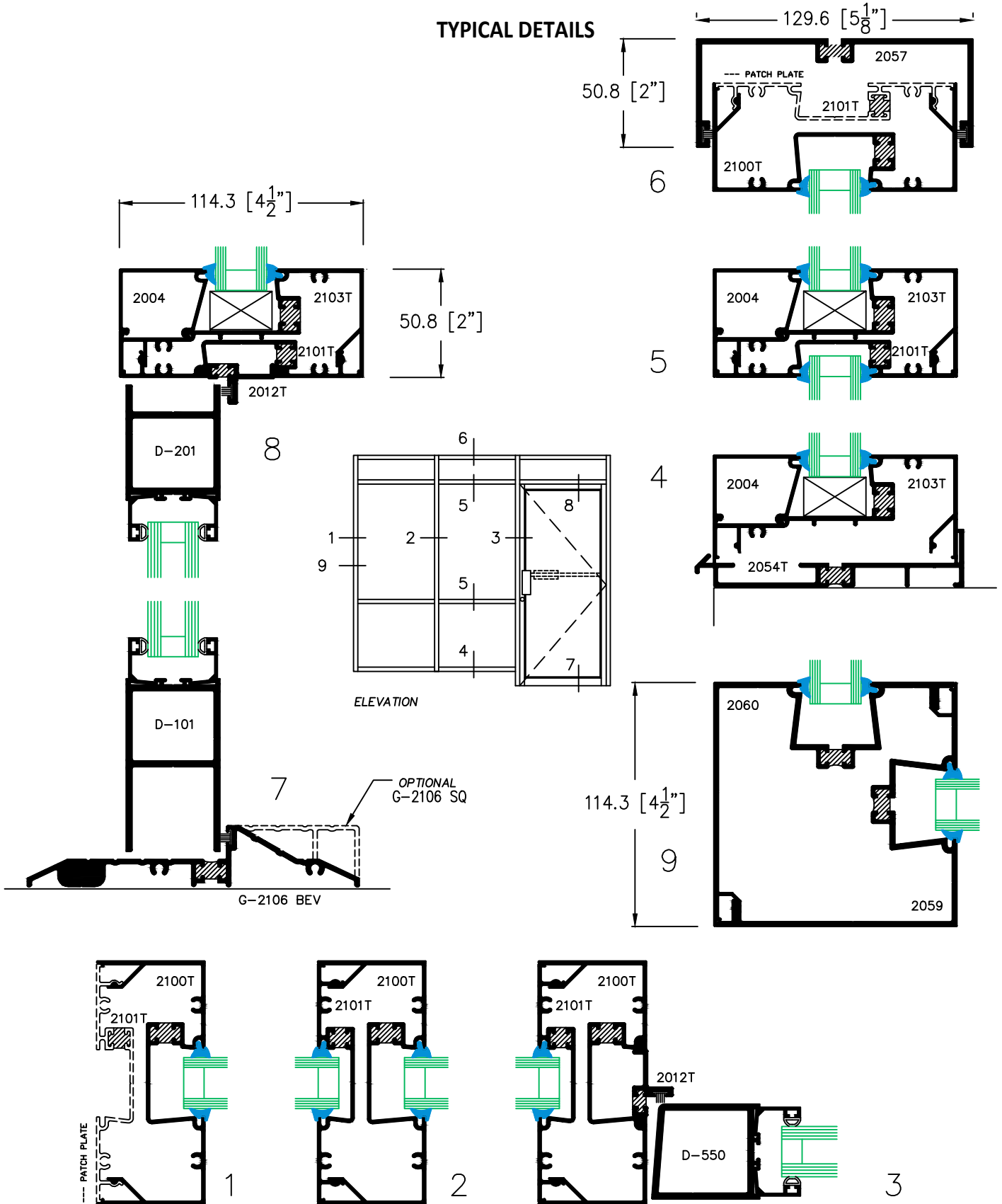

WIND LOAD CHART FOR 2100T SERIES - PART # 2100T/2101T

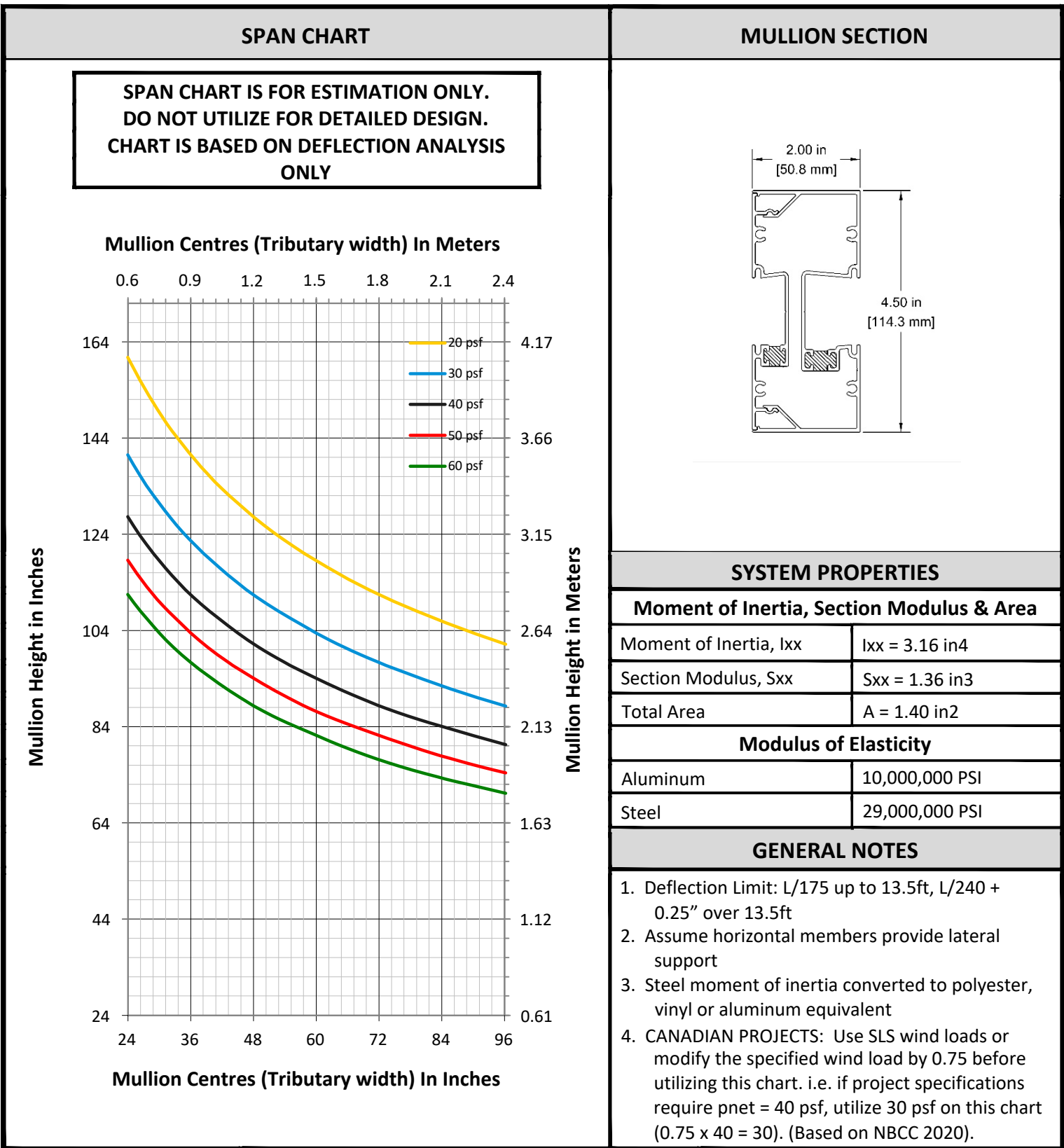

DEAD LOAD CHART FOR 2100T SERIES - PART # 2056

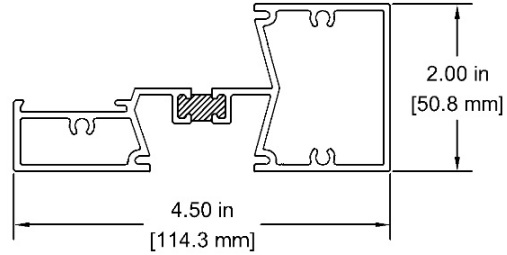
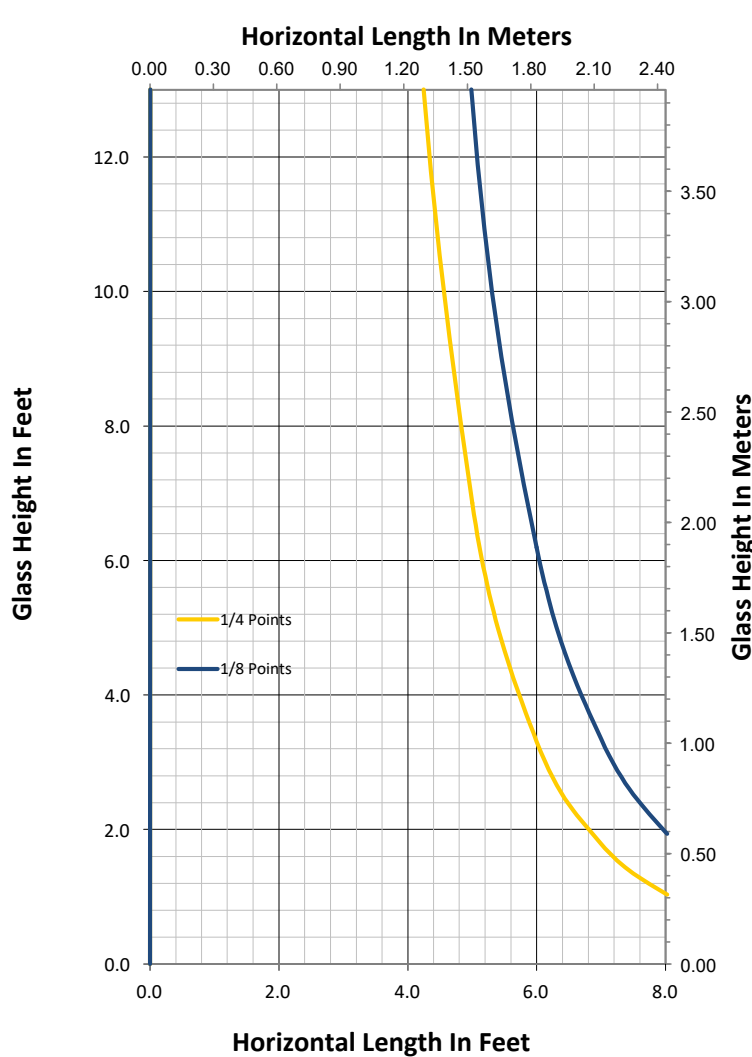
SPAN CHART	MULLION SECTION																				
<p>SPAN CHART IS FOR ESTIMATION ONLY. DO NOT UTILIZE FOR DETAILED DESIGN. CHART IS BASED ON DEFLECTION ANALYSIS ONLY</p>																					
	<table border="1" style="width: 100%; border-collapse: collapse;"> <thead> <tr> <th colspan="2" style="text-align: center;">SYSTEM PROPERTIES</th> </tr> <tr> <th colspan="2" style="text-align: center;">Moment of Inertia, Section Modulus & Area</th> </tr> </thead> <tbody> <tr> <td style="width: 50%;">Moment of Inertia, I_{yy}</td> <td>$I_{yy} = 0.51 \text{ in}^4$</td> </tr> <tr> <td>Section Modulus, S_{yy}</td> <td>$S_{yy} = 0.42 \text{ in}^3$</td> </tr> <tr> <td>Total Area</td> <td>$A = 1.24 \text{ in}^2$</td> </tr> <tr> <th colspan="2" style="text-align: center;">Modulus of Elasticity</th> </tr> <tr> <td>Aluminum</td> <td>10,000,000 PSI</td> </tr> <tr> <td>Steel</td> <td>29,000,000 PSI</td> </tr> <tr> <th colspan="2" style="text-align: center;">GENERAL NOTES</th> </tr> <tr> <td colspan="2"> Deflection Limit: 0.125" (3.2mm). Charts are calculated assuming a 15/16" overall sealed unit (6mm/12mm spacer/6mm). Calculations are based on the position of the setting blocks being placed at either 1/4 or 1/8 points. </td> </tr> </tbody> </table>	SYSTEM PROPERTIES		Moment of Inertia, Section Modulus & Area		Moment of Inertia, I_{yy}	$I_{yy} = 0.51 \text{ in}^4$	Section Modulus, S_{yy}	$S_{yy} = 0.42 \text{ in}^3$	Total Area	$A = 1.24 \text{ in}^2$	Modulus of Elasticity		Aluminum	10,000,000 PSI	Steel	29,000,000 PSI	GENERAL NOTES		Deflection Limit: 0.125" (3.2mm). Charts are calculated assuming a 15/16" overall sealed unit (6mm/12mm spacer/6mm). Calculations are based on the position of the setting blocks being placed at either 1/4 or 1/8 points.	
SYSTEM PROPERTIES																					
Moment of Inertia, Section Modulus & Area																					
Moment of Inertia, I_{yy}	$I_{yy} = 0.51 \text{ in}^4$																				
Section Modulus, S_{yy}	$S_{yy} = 0.42 \text{ in}^3$																				
Total Area	$A = 1.24 \text{ in}^2$																				
Modulus of Elasticity																					
Aluminum	10,000,000 PSI																				
Steel	29,000,000 PSI																				
GENERAL NOTES																					
Deflection Limit: 0.125" (3.2mm). Charts are calculated assuming a 15/16" overall sealed unit (6mm/12mm spacer/6mm). Calculations are based on the position of the setting blocks being placed at either 1/4 or 1/8 points.																					

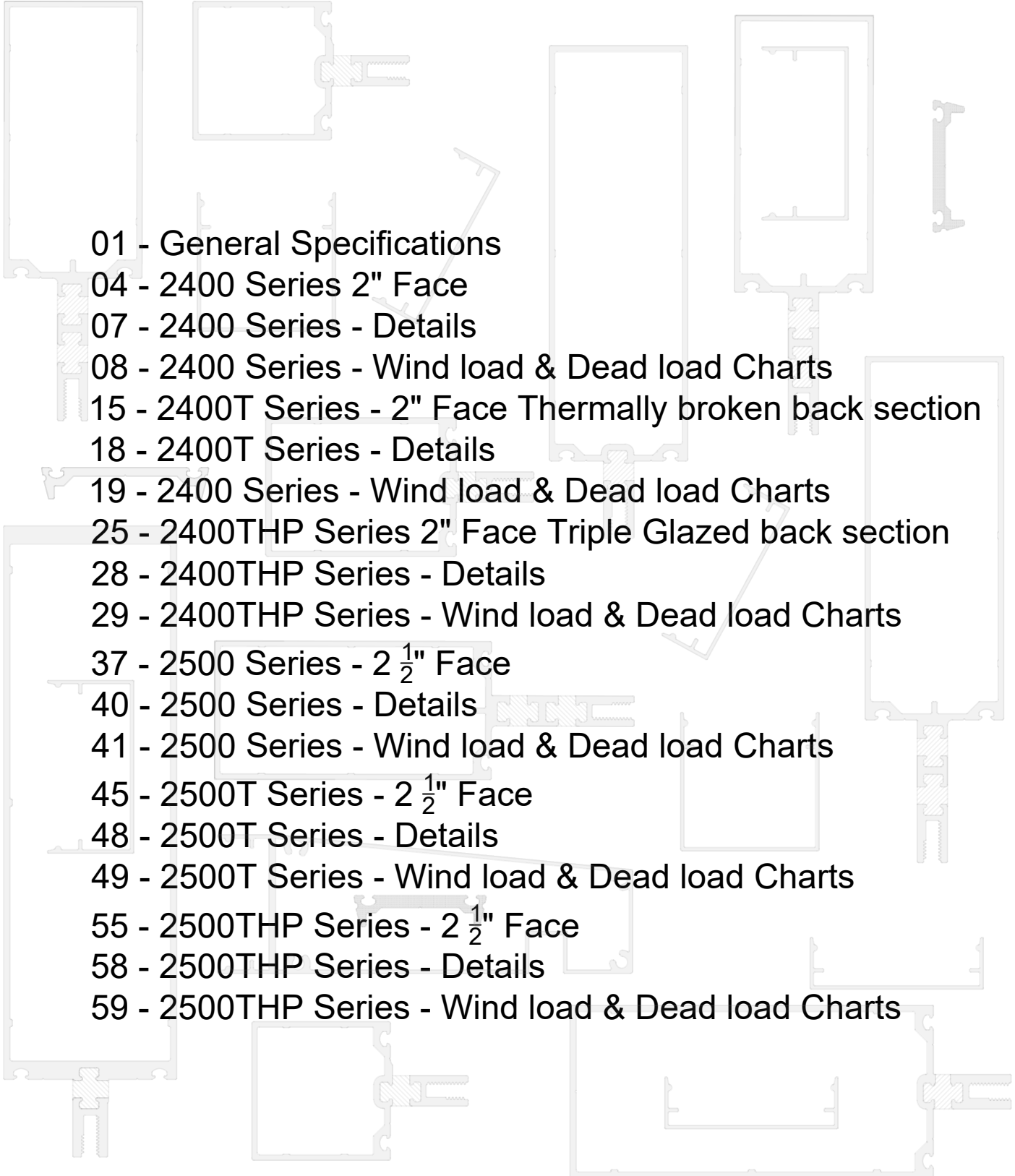
- 
- 01 - General Specifications
 - 04 - 2400 Series 2" Face
 - 07 - 2400 Series - Details
 - 08 - 2400 Series - Wind load & Dead load Charts
 - 15 - 2400T Series - 2" Face Thermally broken back section
 - 18 - 2400T Series - Details
 - 19 - 2400 Series - Wind load & Dead load Charts
 - 25 - 2400THP Series 2" Face Triple Glazed back section
 - 28 - 2400THP Series - Details
 - 29 - 2400THP Series - Wind load & Dead load Charts
 - 37 - 2500 Series - 2 1/2" Face
 - 40 - 2500 Series - Details
 - 41 - 2500 Series - Wind load & Dead load Charts
 - 45 - 2500T Series - 2 1/2" Face
 - 48 - 2500T Series - Details
 - 49 - 2500T Series - Wind load & Dead load Charts
 - 55 - 2500THP Series - 2 1/2" Face
 - 58 - 2500THP Series - Details
 - 59 - 2500THP Series - Wind load & Dead load Charts

Part 1 - GENERAL

Scope - The curtain wall framing system shall be _____ Series as manufactured by METRO ALUMINUM Products Ltd. Supply and install aluminum framing, as described on the architectural drawings and as specified herein.

Work Not Included - See: Specifier's lists of excluded items; Items furnished but not installed and/or Items installed but not furnished.

Related Work Specified Elsewhere - See: Specifier's lists and related Sections.

Design & Performance Requirements - Framing to fully comply with applicable standard specifications as typically referenced to the following performance requirements criteria: Air Tightness, Water Tightness, Wind (and other applicable) Load Resistance, Temperature Index and Energy Performance. (Specifier's selection)

Submittals - Shop Drawings & Samples - Submit all documentation and samples for review by Consultant at one time, prior to fabrication of curtain wall products.

Quality Assurance - Provide all necessary information to show that all involved products meet or exceed the requirements of these specifications.

Delivery, Storage and Handling - Deliver, store, handle, protect and schedule materials and products so as to avoid any damage. Follow recommendations of AAMA CW-10 "Care and Handling of Architectural Aluminum from Shop to Site" and others as applicable.

Part 2 - PRODUCTS

Materials - All materials to meet the applicable minimum design and specifications requirements. Any defects impairing strength, durability or appearance are not acceptable. Extruded aluminum shall be AA 6063 T6 alloy and temper - Fy = 110 MPa (16 KSI) minimum. Sufficient strength and size assembly fasteners and anchoring bolts shall be made of corrosion-resistant and compatible material such as cadmium or zinc plated carbon steel or stainless steel. Separate incompatible materials and prevent galvanic action (electrolytic corrosion). Structurally adequate anchoring metal brackets shall be anticorrosive painted. Standard gaskets, dense exterior and sponge interior, shall be extruded from Neoprene, EPDM, or other equal material as required for conventional dry-dry, outside glazing method. Gasket profile shall be designed and sized to uniformly fit tight and properly seal glass-metal interfacing. Acceptable gasket compression range to be 0.7 to 1.7 kN/m (4 – 10 lbs/in). Glass setting to be compatible with glass unit seals and/or other parts involved as required.

System Description - Framing System, thermally broken/insulated for sealed insulating glass units and spandrel single glass, utilizing Rainscreen Principle and allowing for full integration with the building envelope, shall be 2400/2500 - METRO Series (Specifier's selection) as manufactured by METRO ALUMINUM Products Ltd.

Reference dimensions of extruded profiles shall be (Specifier's selection):

2400 Series - 2" (50.8 mm) face width, and
2500 Series - 2.5" (63.5 mm) face width.

Glass retention, as for dry-dry glazing method, shall be achieved by 4-side pressure plate (retainer) profile and inorganic rubber gasket. Glass hard bite to be 12.7 mm (0.5") minimum.

Whenever substitute/alternative products are considered, supporting data to be submitted ten (10) days prior to bid date to allow for valid comparison. Approval of alternates to be confirmed in advance of bid closing by addendum only.

Fabrication - Extruded profiles shall be accurately fabricated and assembled and sealed to provide air/water tight fit hairline joints only. Fastening shall allow for permanent true and square set of frame elements. Assembly shall utilize concealed spigots and screws and/or screws only. Properly sealed frame assembly joints and corner blocks to result in continuity of air barrier and full compartmentization. Frame assemblies shall be free of warp. Uniformly compressed glazing gaskets shall secure glass in place. No exposed fasteners are permitted.

Finish - All exposed surfaces shall be finished as specified. The finish, as per AAM designation, shall be (Specifier's selection):

Standard clear anodizing to AA - M12C22A31

Standard perma bronze to AA - M12C22A44

Standard black anodized to AA - M10C21A44

Duracron acrylic enamel to AA - M12C4XR1X

Custom paint qualities and colors - Specifier's selection.

Hardware to have manufacturer's standard finish.

Part 3 - EXECUTION

Installation - Steel embeds and anchoring brackets to be placed and ready as required. Anchoring shall suit perimeter conditions of rough openings and seals as required. Stick or prefabricated framing to be installed at prepared structure, at correct locations as shown on drawings, set level, plumb, square and aligned with other work in accordance with manufacturer's instructions, approved shop and erection drawings. Perimeter joints to be sealed/caulked as specified and detailed to ensure weathertight assembly.

Protection and Cleaning - Work to be protected from damage during and after installation. Consult with manufacturer and installer to determine appropriate protective measures. The General Contractor shall be responsible for protection during construction and for final cleaning. After installation, aluminum work and glass to be cleaned according to instructions/manuals provided by product manufacturers and glaziers. Use appropriate cleaning materials and methods. Do not scratch or damage glass or finishes.



**METRO
ALUMINUM**

Products Ltd.

2400 SERIES

CURTAIN WALL & WINDOW SYSTEM
NARROW - 2" (50.8 mm) - FRAME

D

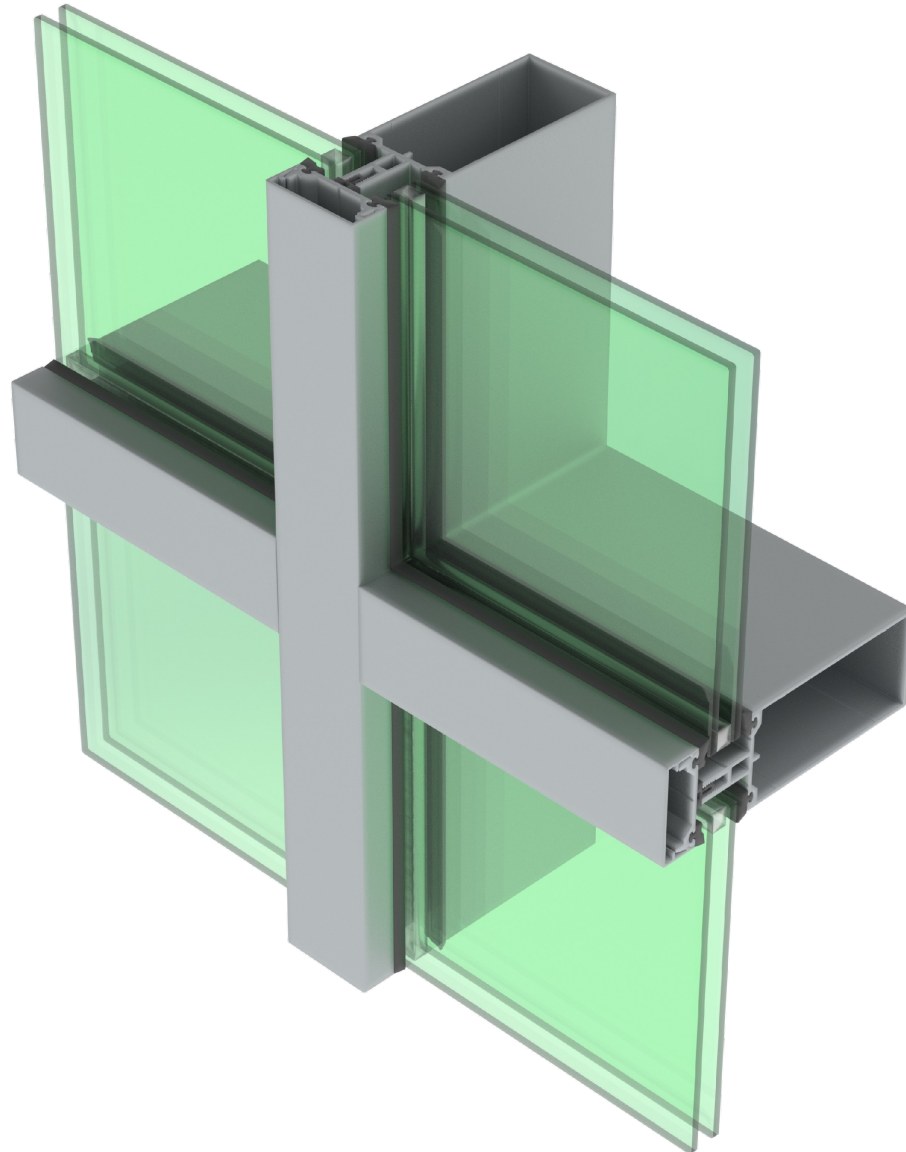



**METRO
ALUMINUM**
Products Ltd.

2400 SERIES

CURTAIN WALL & WINDOW SYSTEM
NARROW - 2" (50.8 mm) - FRAME

**D
02**

PICTORIAL (3D) PRESENTATION

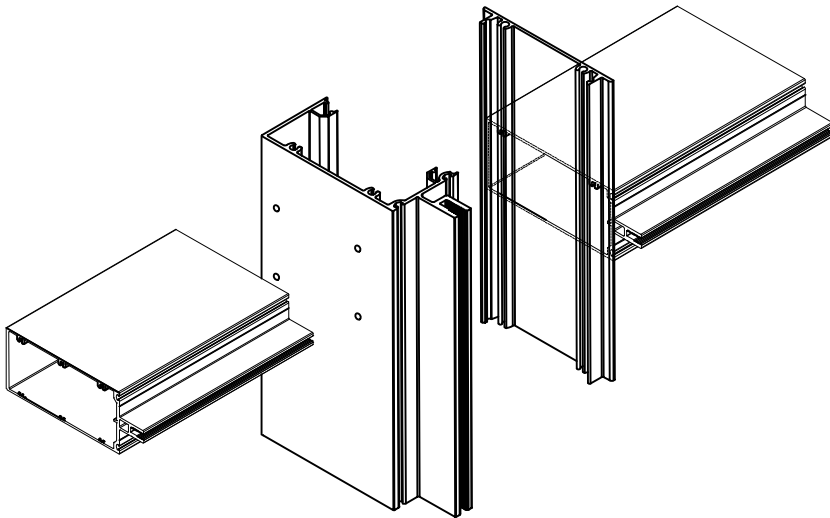

UNITIZED SYSTEM

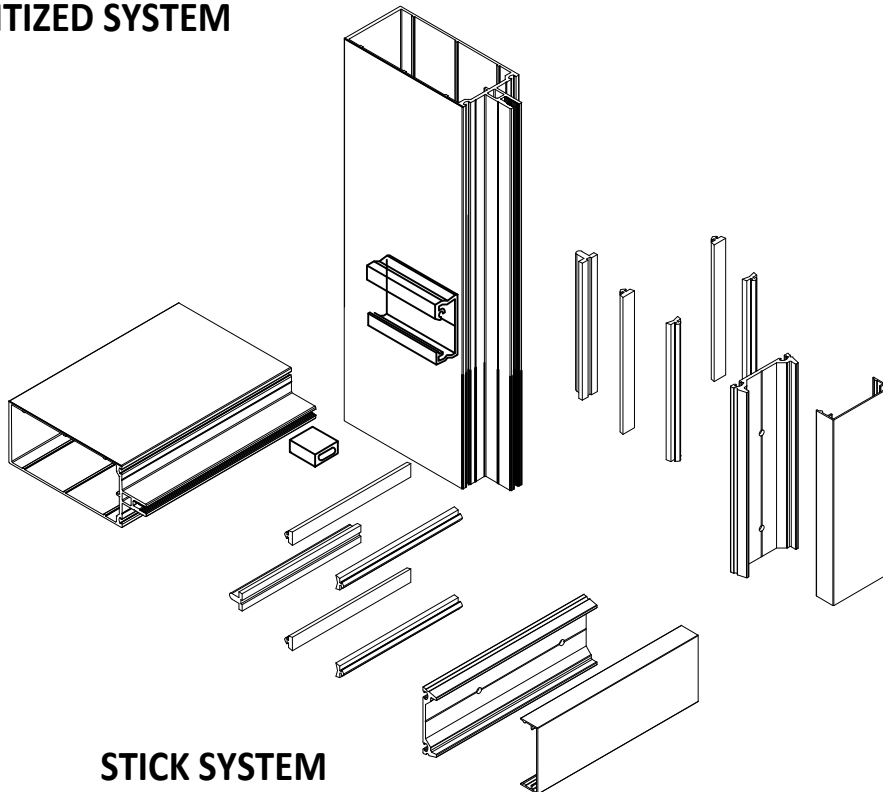
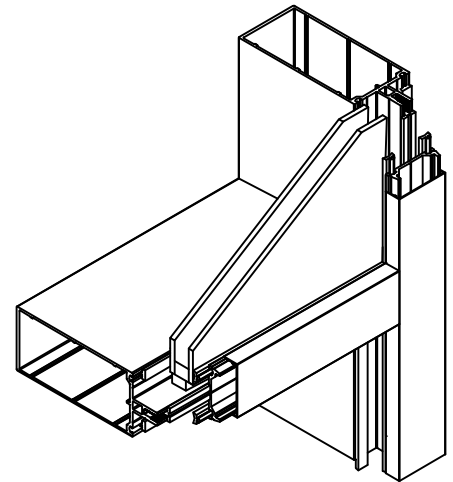

STICK SYSTEM



**METRO
ALUMINUM**
Products Ltd.

2400 SERIES

CURTAIN WALL & WINDOW SYSTEM
2" (50.8 mm) - FRAME

**D
03**

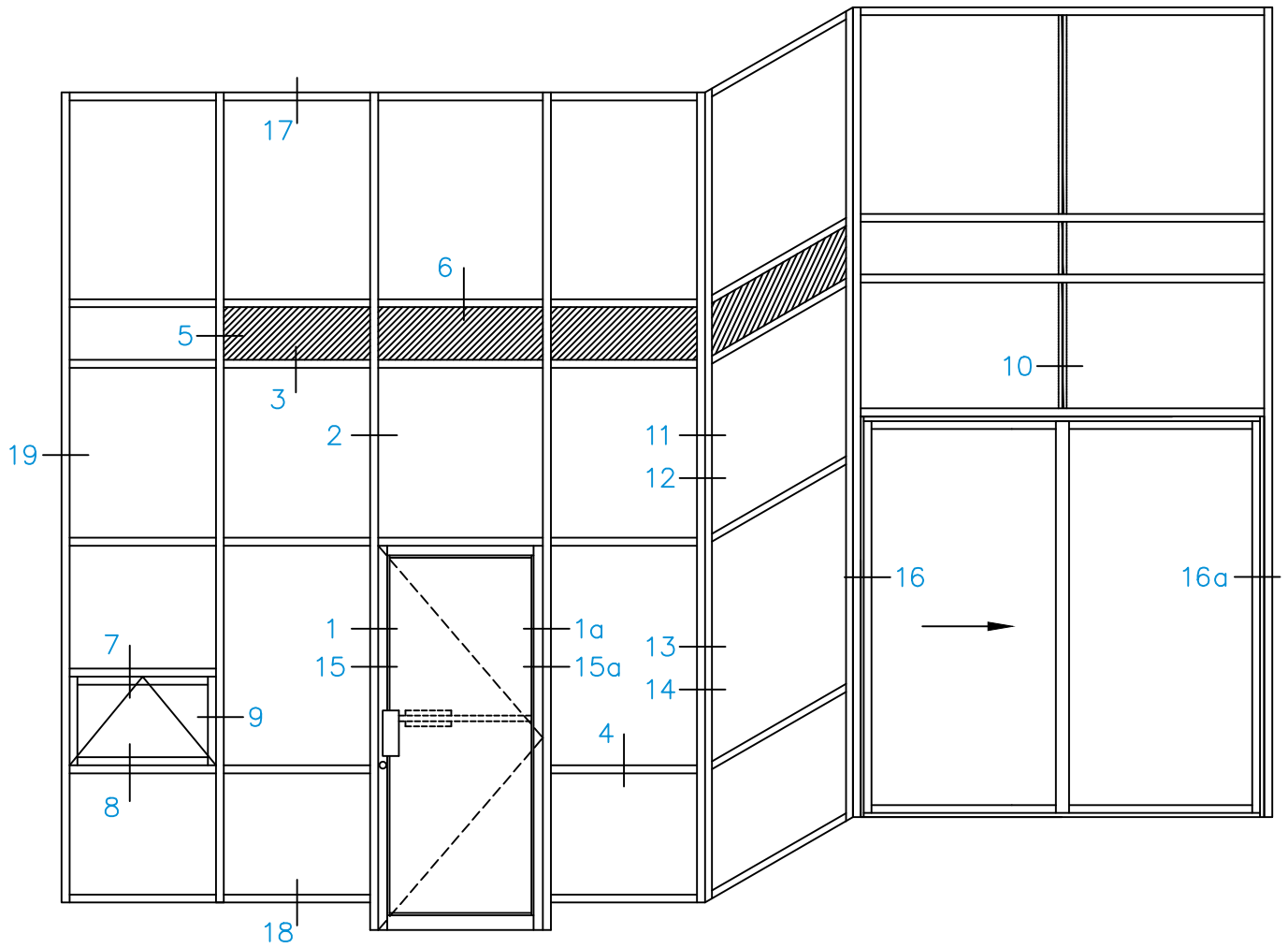

ELEVATION



BACK SECTIONS & CAPS

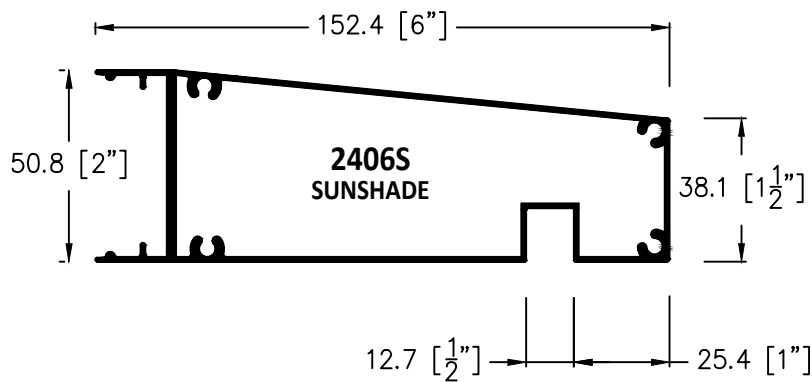
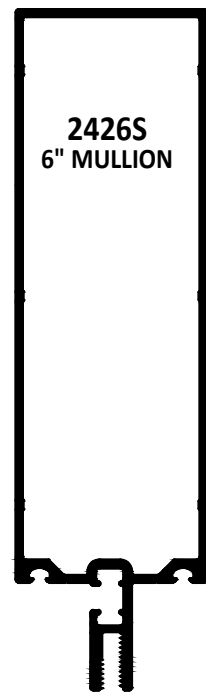
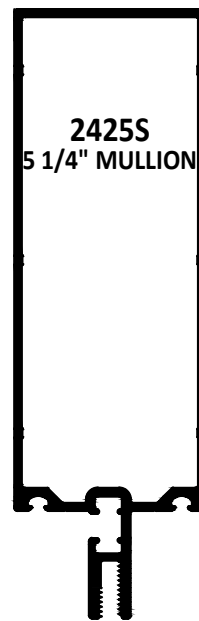
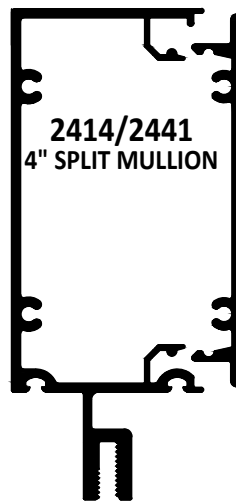
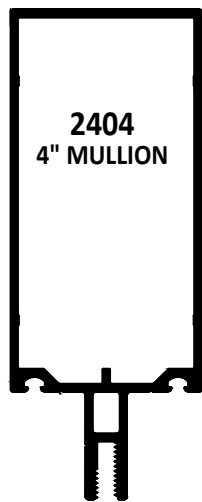
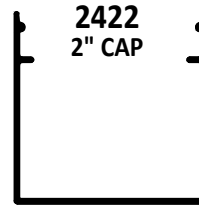
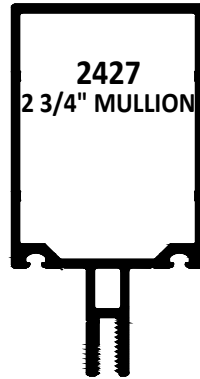
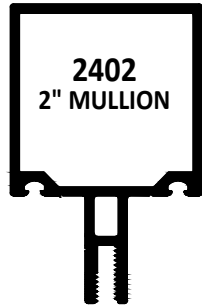



**METRO
ALUMINUM**
Products Ltd.

2400 SERIES

CURTAIN WALL & WINDOW SYSTEM
NARROW - 2" (50.8 mm) - FRAME

**D
05**

SSG & CORNERS

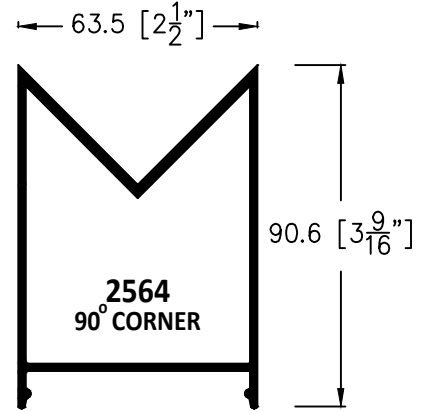
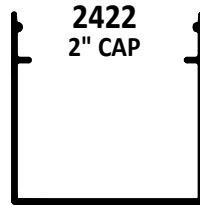
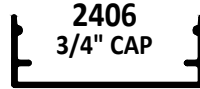

EXTENSION CAP FOR 4" BACK

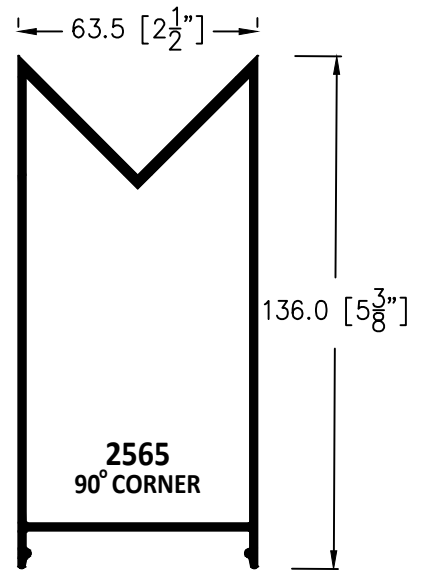
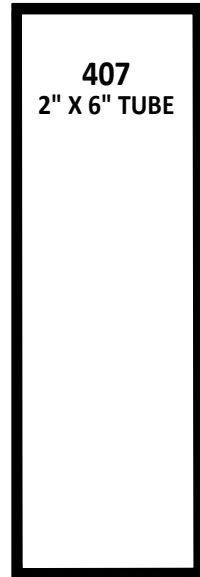
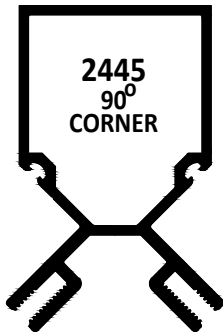

EXTENSION CAP FOR 5 1/4" BACK

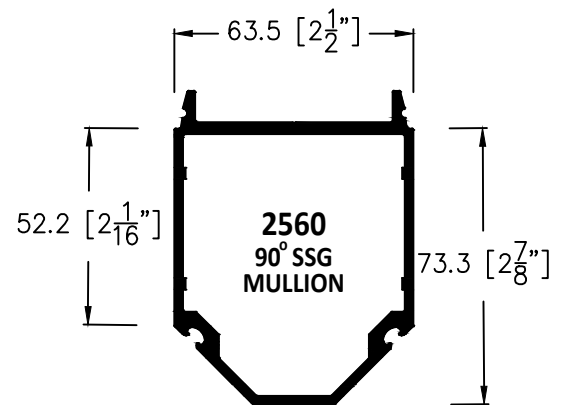
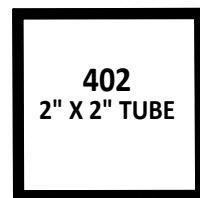
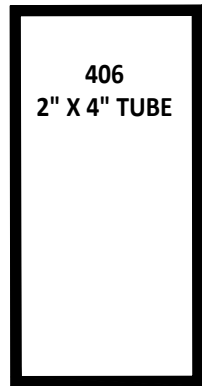



MISC. COMPONENTS

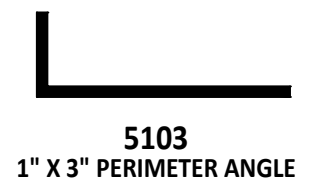
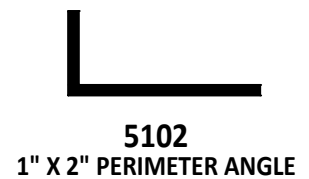
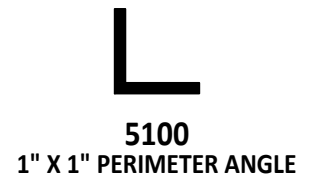
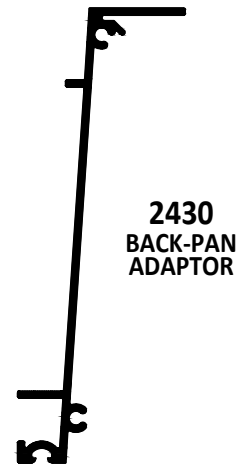
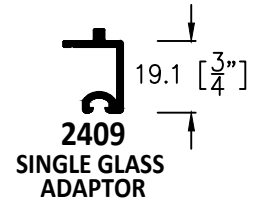
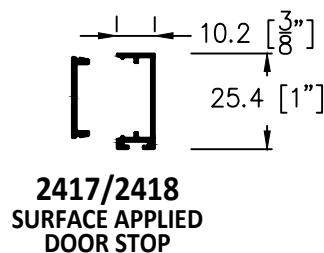
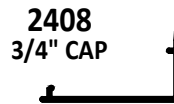
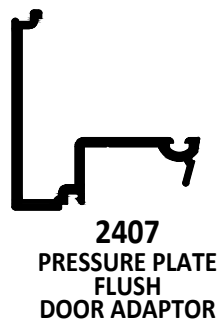
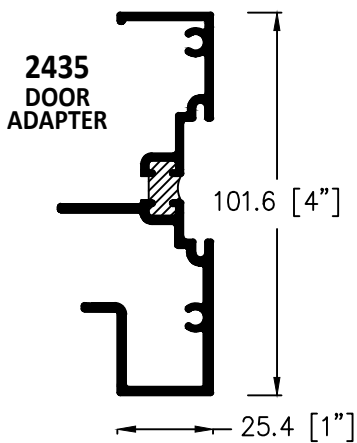
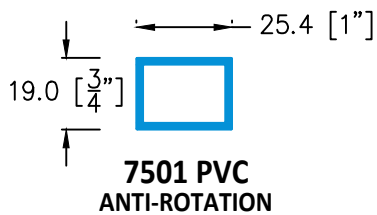



TYPICAL DETAILS

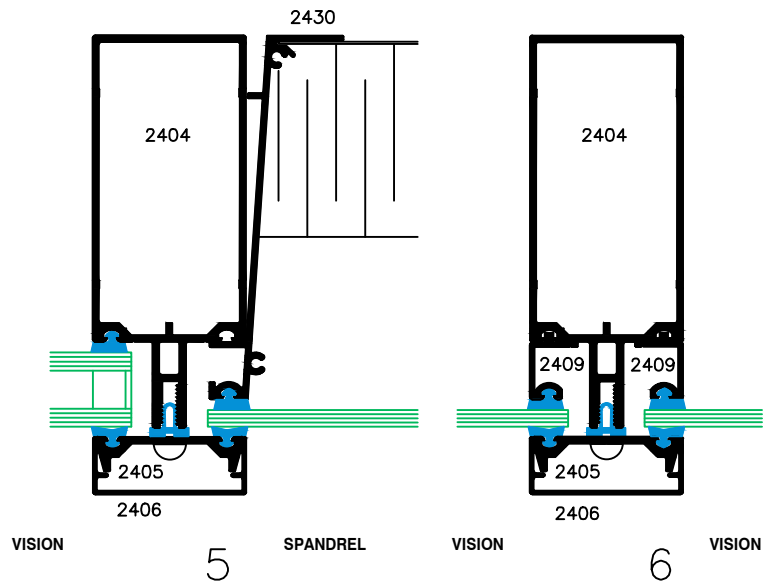
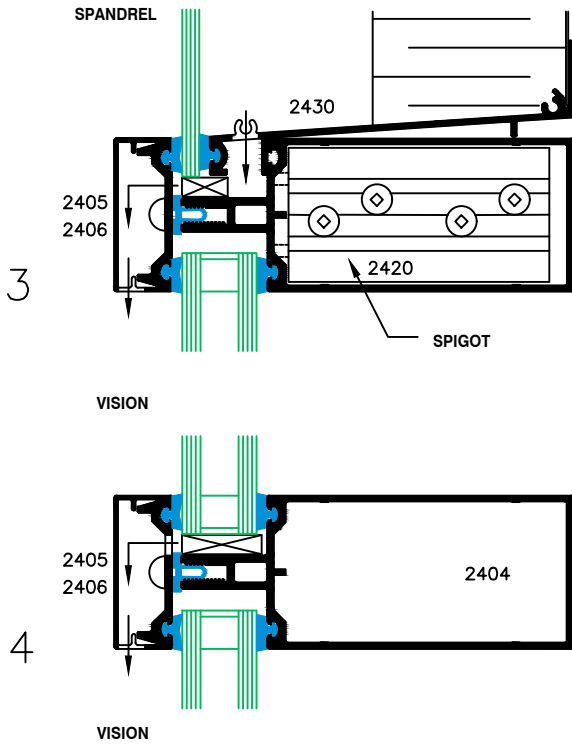
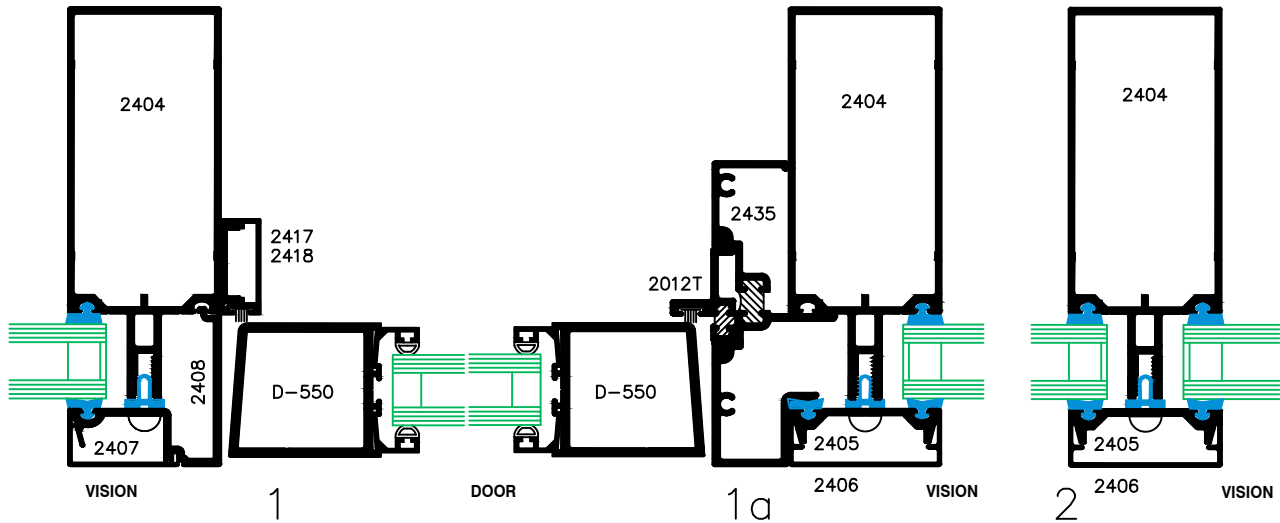

TYPICAL CURTAIN WALL DETAILS

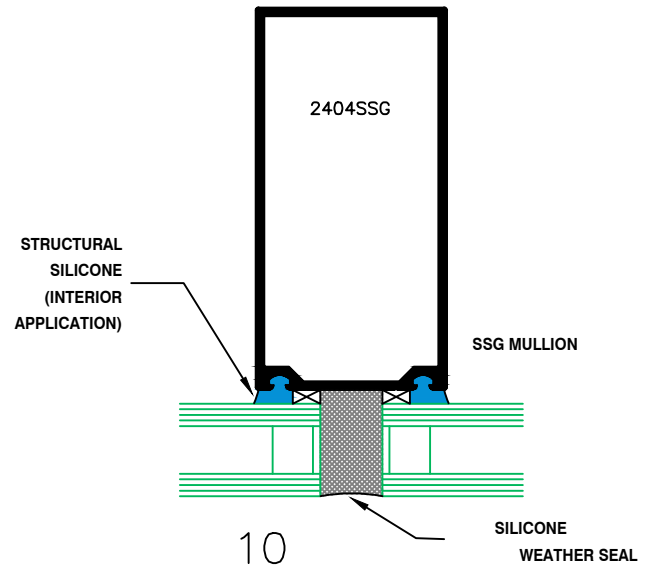
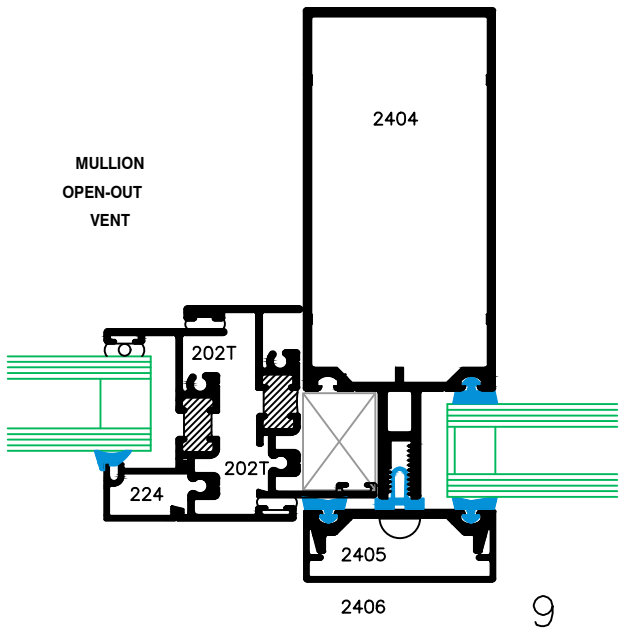
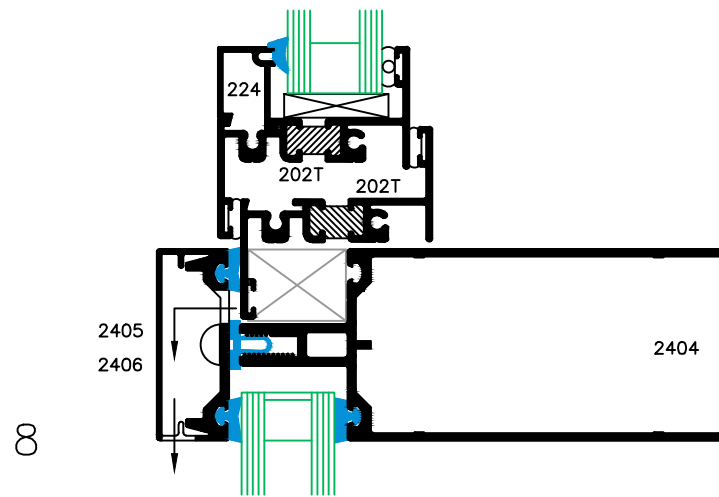
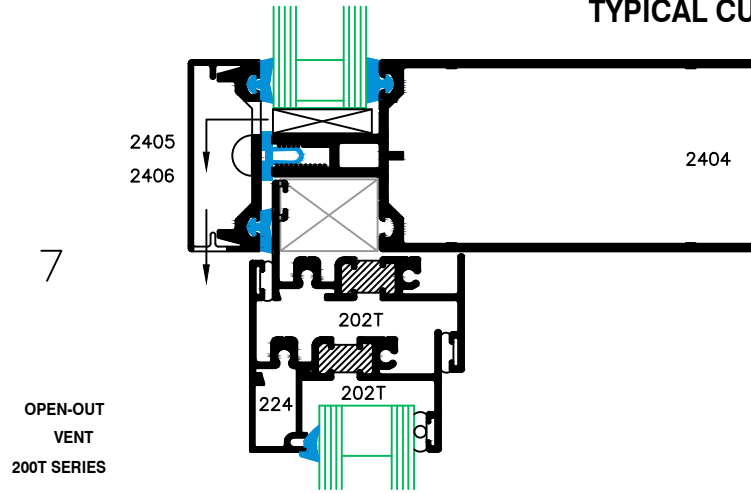



TYPICAL CAPTURED CORNER DETAILS

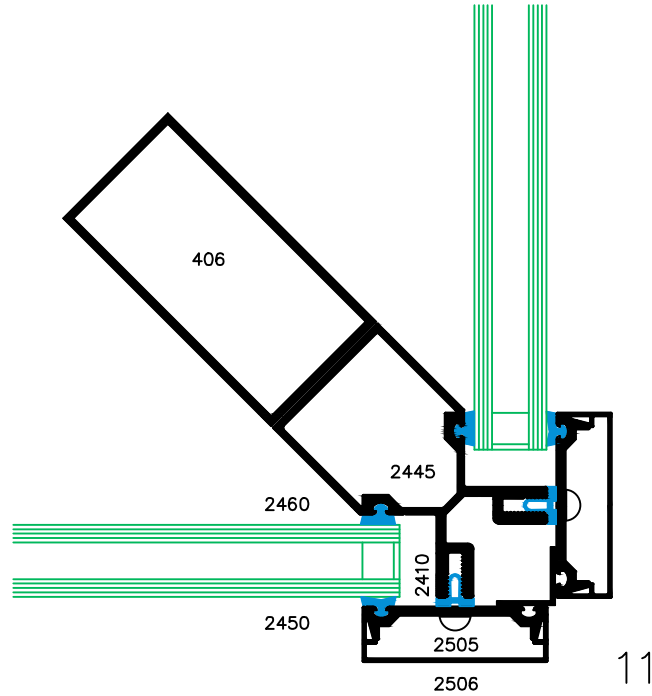

90° CAPTURED CORNER

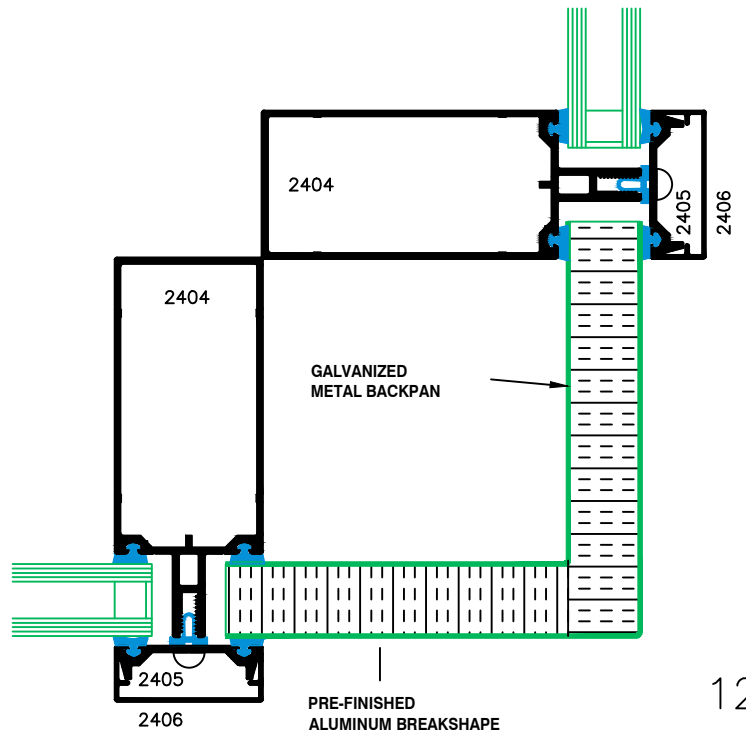

90° BREAKSHAPE CORNER



TYPICAL BUTT-JOINT CORNER DETAILS

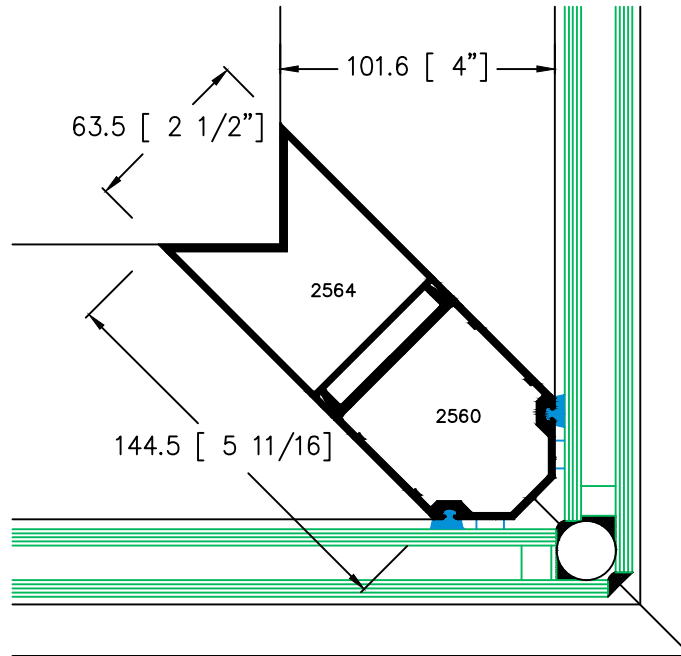

90° BUTT-JOINT CORNER
AT 4" BACK MEMBER

13

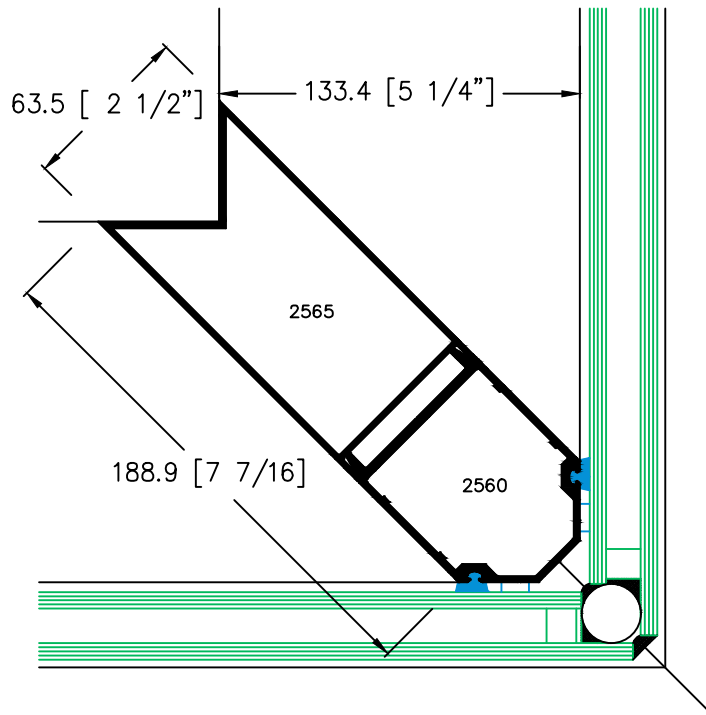

90° BUTT-JOINT CORNER
AT 5 1/4" BACK MEMBER

14

ALTERNATE DOOR DETAILS

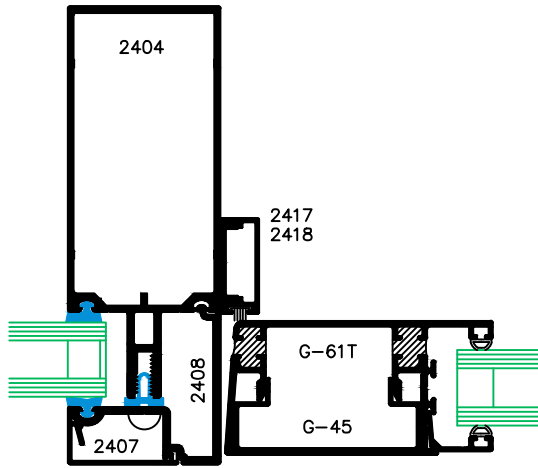

GLACIER DOOR

15

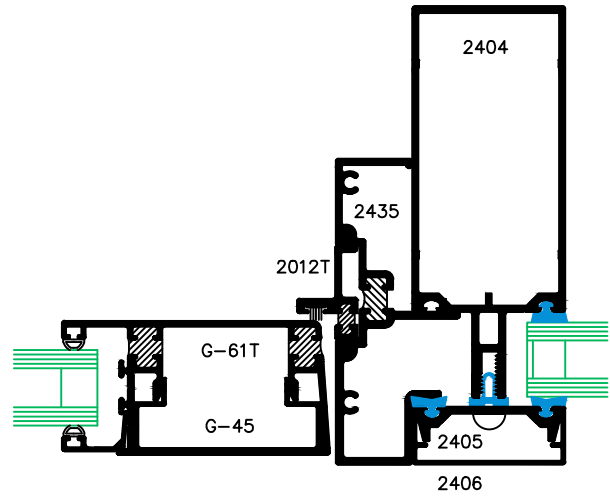

SWING DOORS

15a

GLACIER DOOR

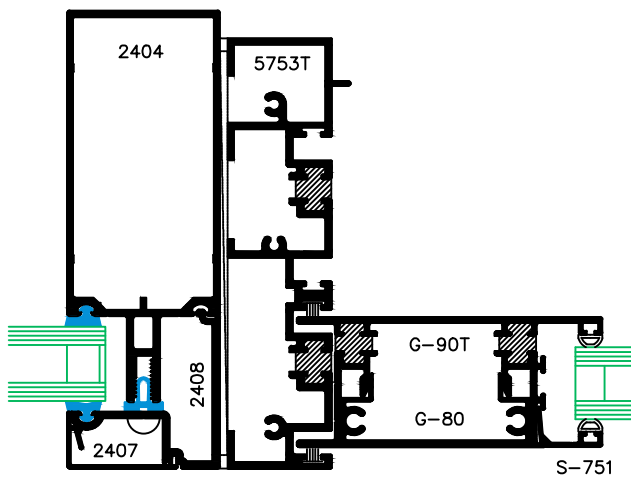

1100T JAMB AT SLIDER

16

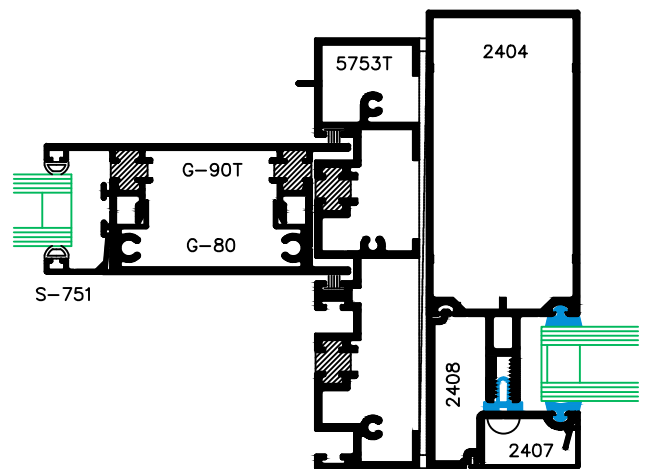

SLIDING DOORS

16a

1100T JAMB AT FIXED PANEL



**INTERFACE DETAILS
(SUGGESTED ONLY)**

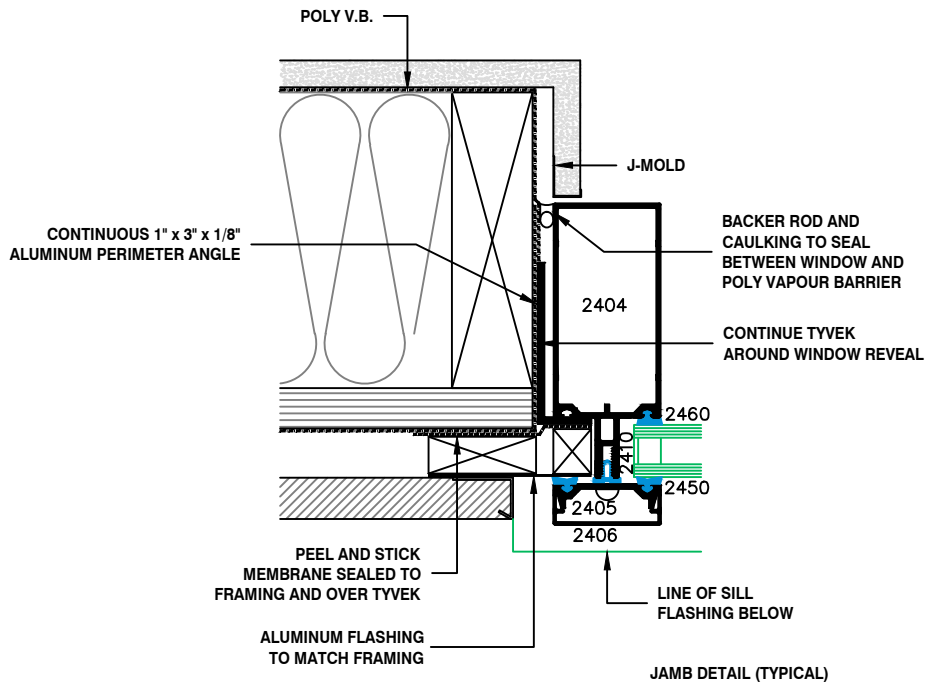
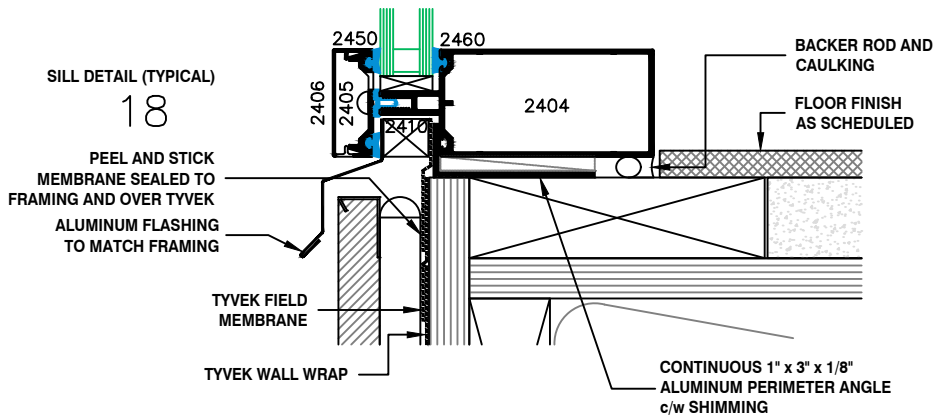
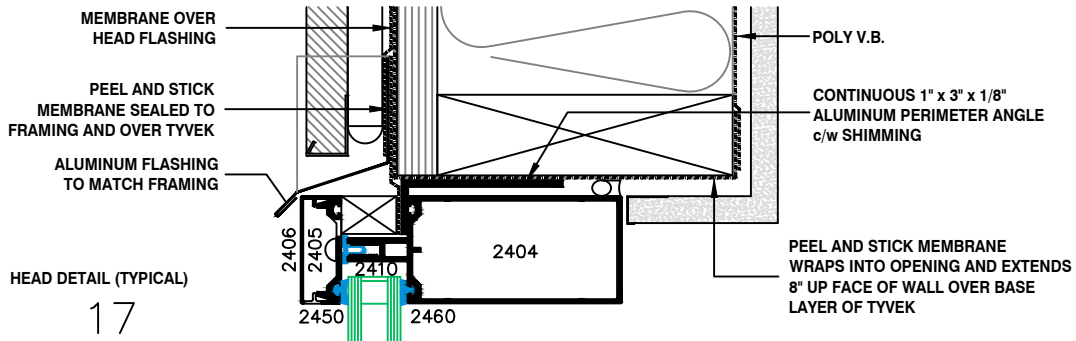



TYPICAL ANCHORING DETAILS

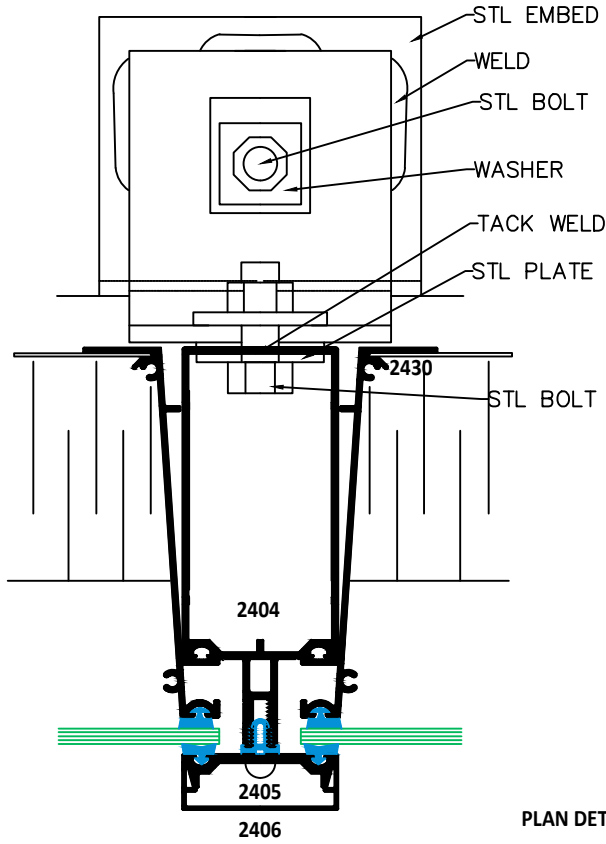

PLAN DETAILS

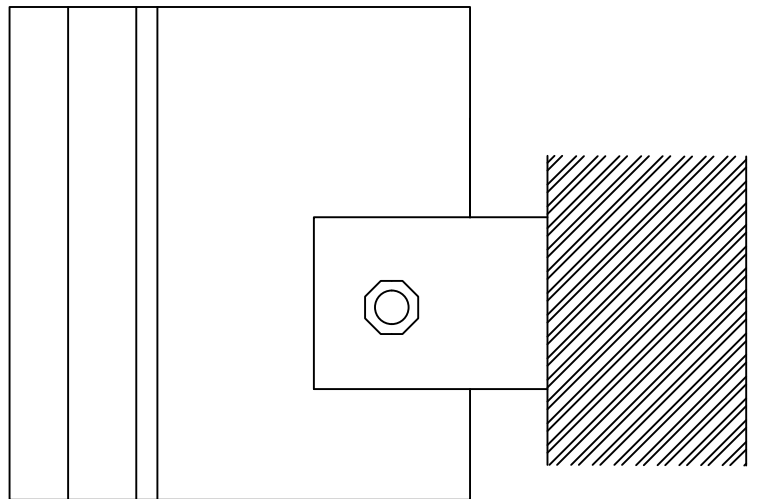
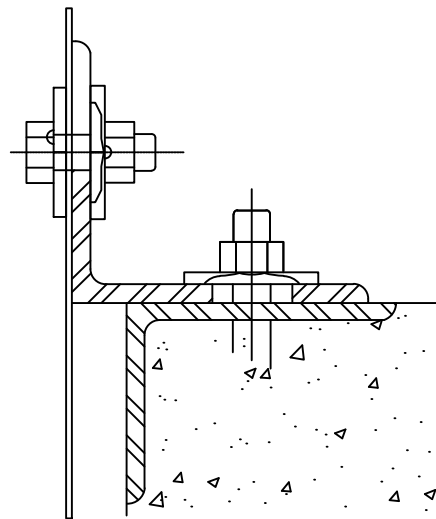
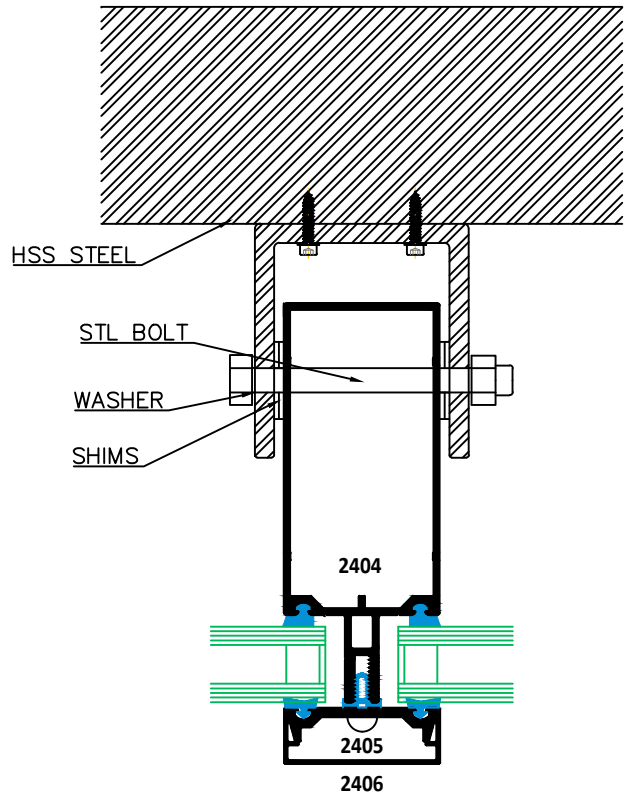

SECTION DETAILS

EXPANSION & SPLICE DETAILS

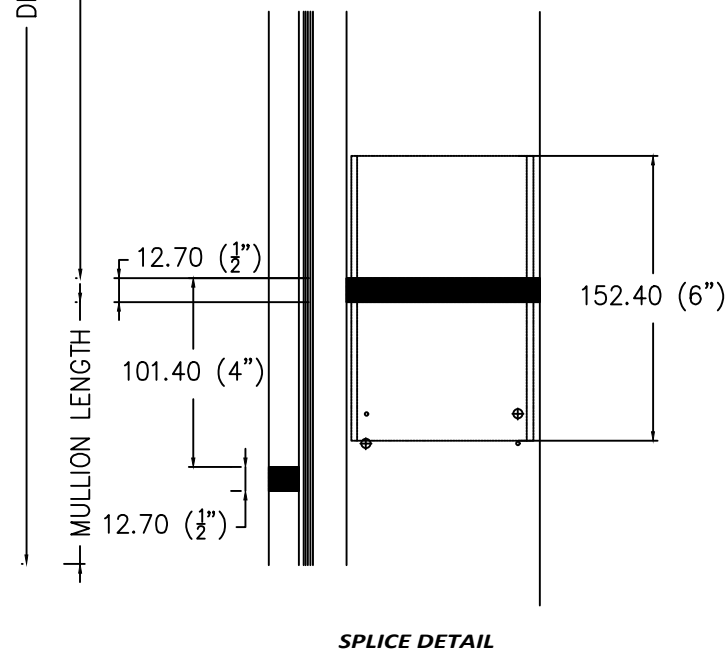
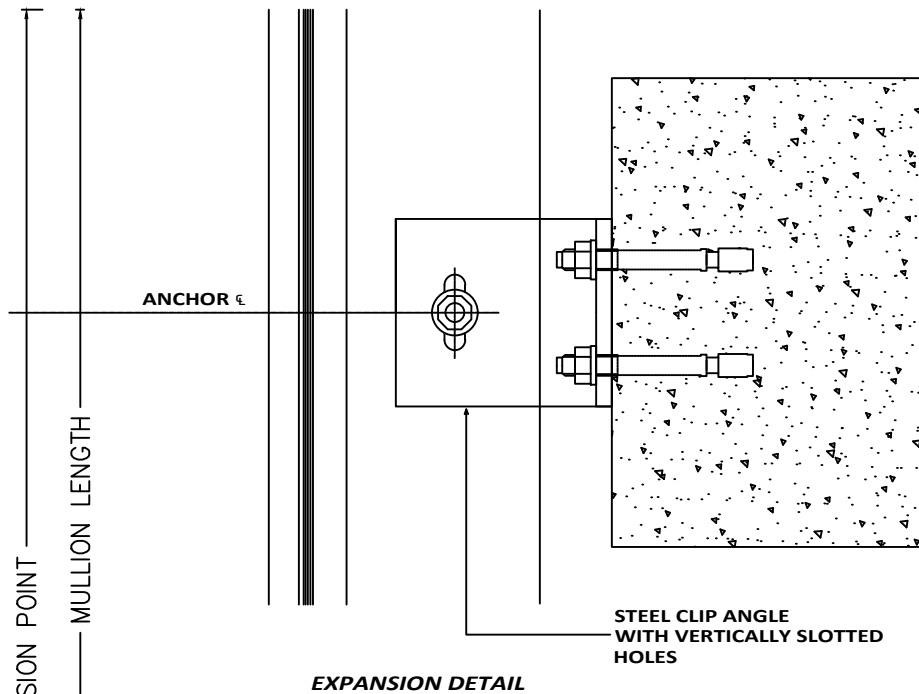

WIND LOAD CHART FOR 2" x 2" MULLION - PART # 2402

SPAN CHART

SPAN CHART IS FOR ESTIMATION ONLY.
DO NOT UTILIZE FOR DETAILED DESIGN.
CHART IS BASED ON DEFLECTION ANALYSIS
ONLY

Mullion Centres (Tributary width) In Meters

0.6 0.9 1.2 1.5 1.8 2.1 2.4

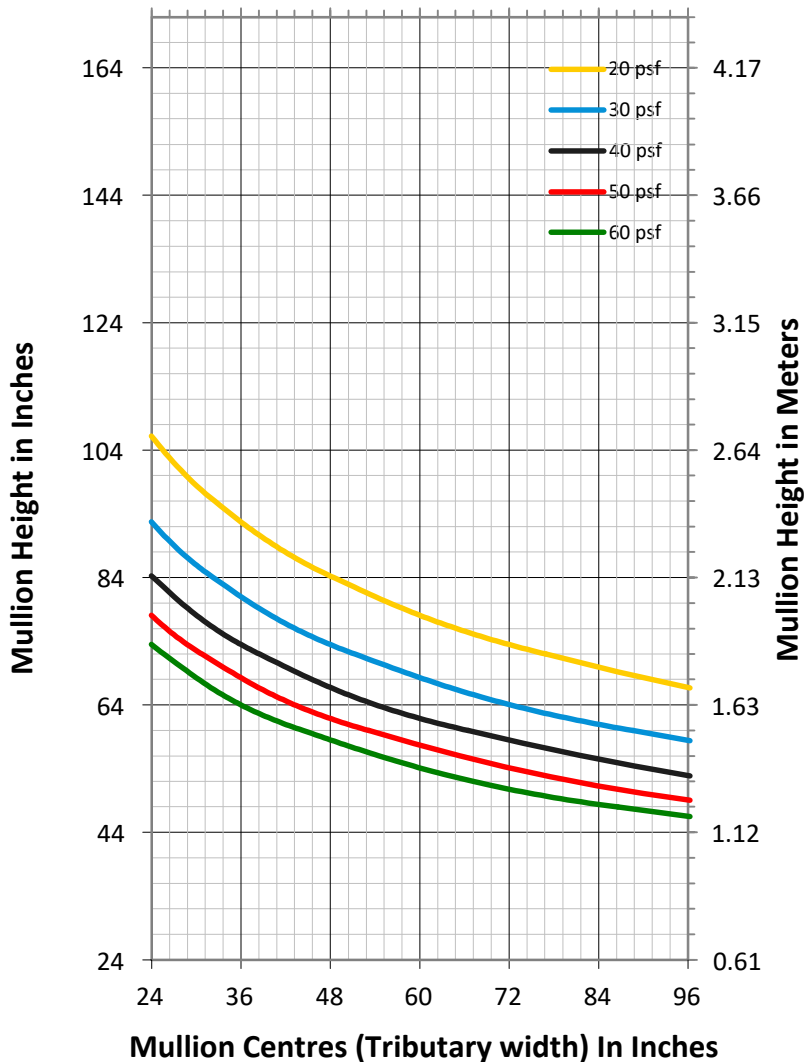

MULLION SECTION

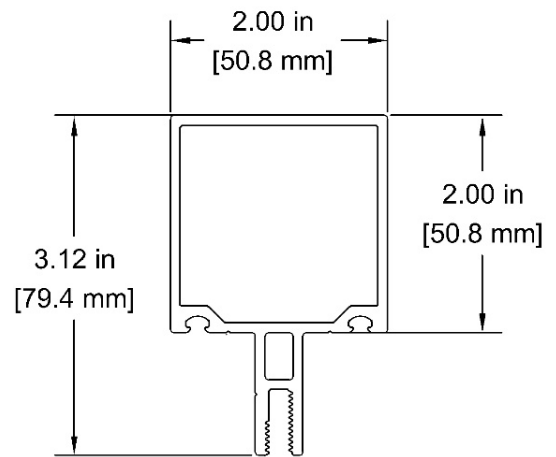

SYSTEM PROPERTIES

Moment of Inertia, Section Modulus & Area

Moment of Inertia, I _{xx}	I _{xx} = 0.91 in ⁴
Section Modulus, S _{xx}	S _{xx} = 0.54 in ³
Total Area	A = 0.99 in ²

Modulus of Elasticity

Aluminum	10,000,000 PSI
Steel	29,000,000 PSI

GENERAL NOTES

1. Deflection Limit: L/175 up to 13.5ft, L/240 + 0.25" over 13.5ft
2. Assume horizontal members provide lateral support
3. Steel moment of inertia converted to polyester, vinyl or aluminum equivalent
4. CANADIAN PROJECTS: Use SLS wind loads or modify the specified wind load by 0.75 before utilizing this chart. i.e. if project specifications require p_{net} = 40 psf, utilize 30 psf on this chart (0.75 x 40 = 30). (Based on NBCC 2020).

DEAD LOAD CHART FOR 2" x 2" MULLION - PART # 2402

SPAN CHART

SPAN CHART IS FOR ESTIMATION ONLY.
DO NOT UTILIZE FOR DETAILED DESIGN.
CHART IS BASED ON DEFLECTION ANALYSIS
ONLY

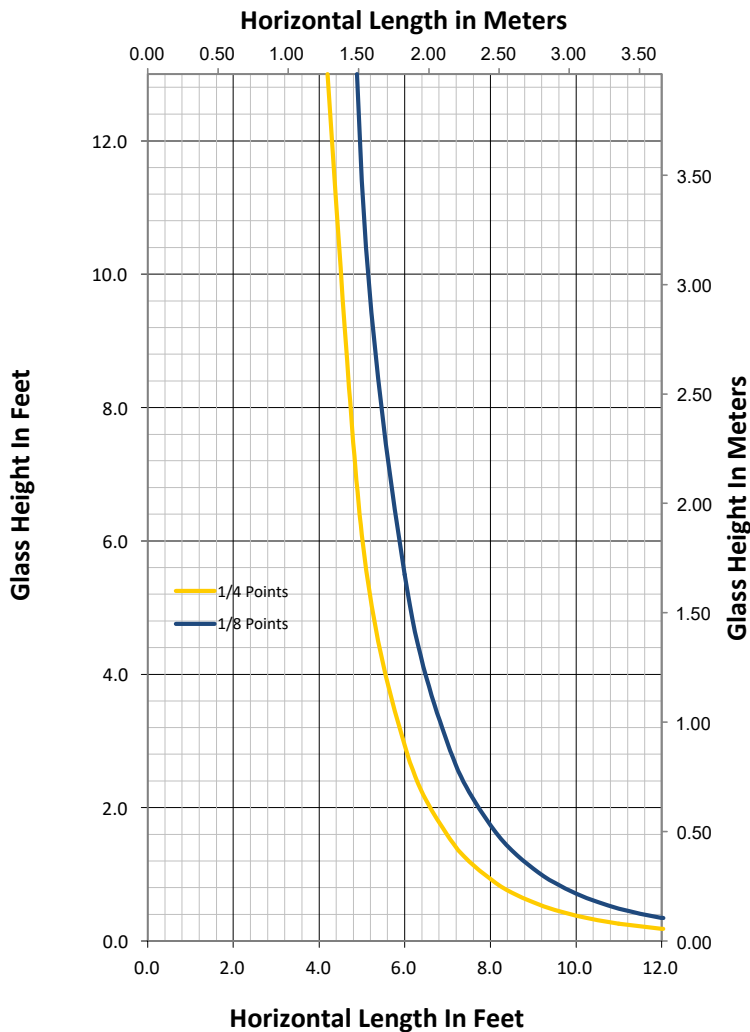

MULLION SECTION

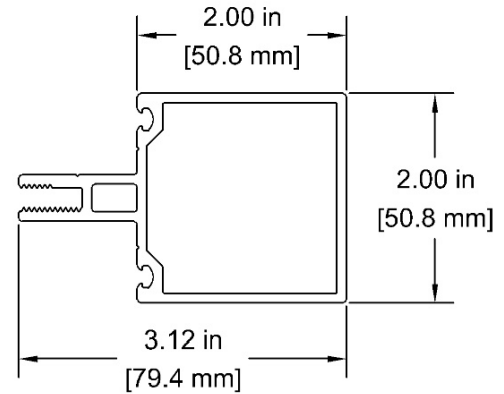

SYSTEM PROPERTIES

Moment of Inertia, Section Modulus & Area

Moment of Inertia, I_{yy}	$I_{yy} = 0.45 \text{ in}^4$
Section Modulus, S_{yy}	$S_{yy} = 0.45 \text{ in}^3$
Total Area	$A = 0.99 \text{ in}^2$

Modulus of Elasticity

Aluminum	10,000,000 PSI
Steel	29,000,000 PSI

GENERAL NOTES

1. Deflection Limit: 0.125" (3.2mm).
2. Charts are calculated assuming a 1" overall sealed unit (6mm/13mm spacer/6mm)
3. Calculations are based on the position of the setting blocks being placed at 1/4 or 1/8 points.

WIND LOAD CHART FOR 2" x 2 3/4" MULLION - PART # 2427

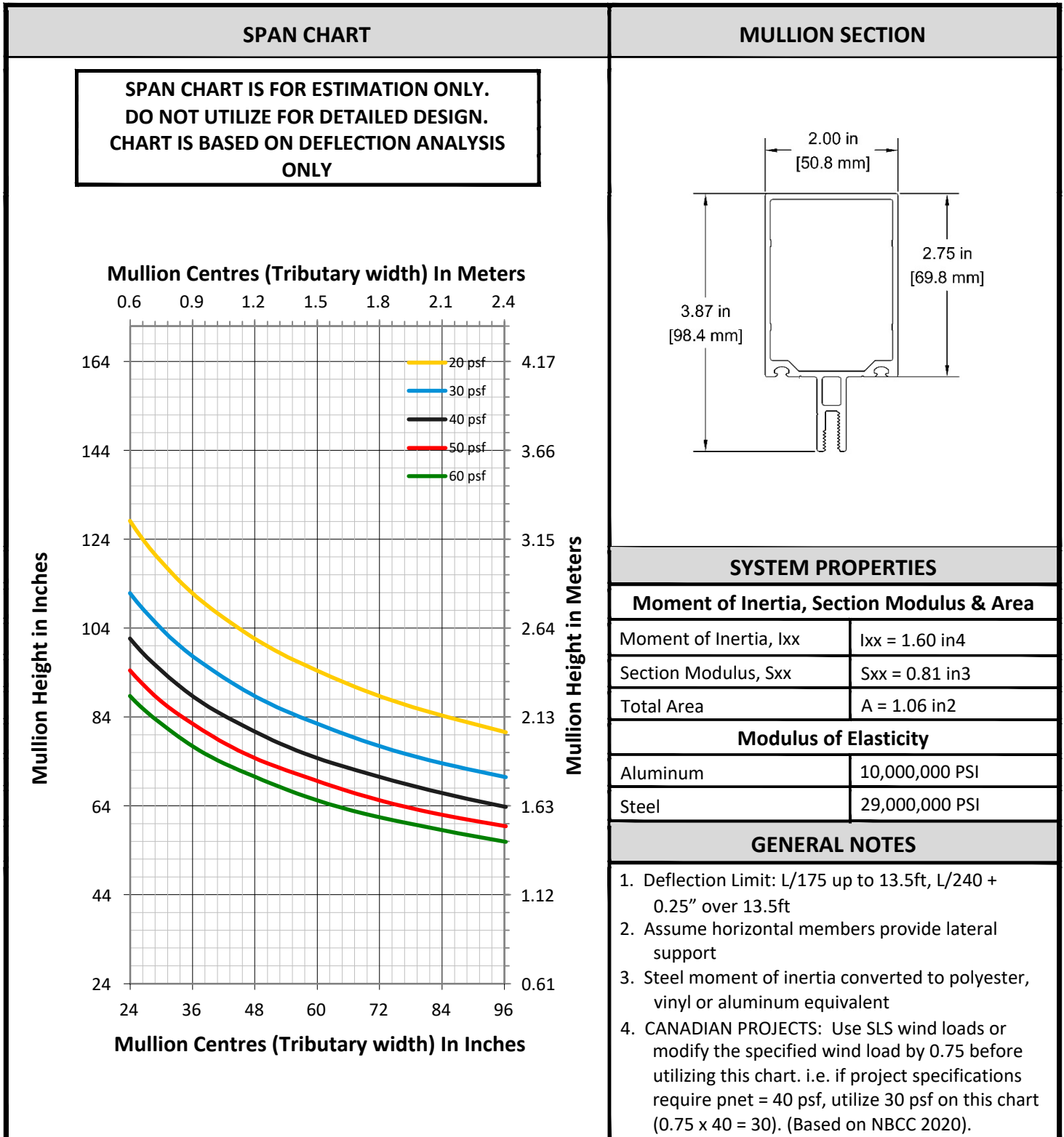

DEAD LOAD CHART FOR 2" x 2 3/4" MULLION - PART # 2427

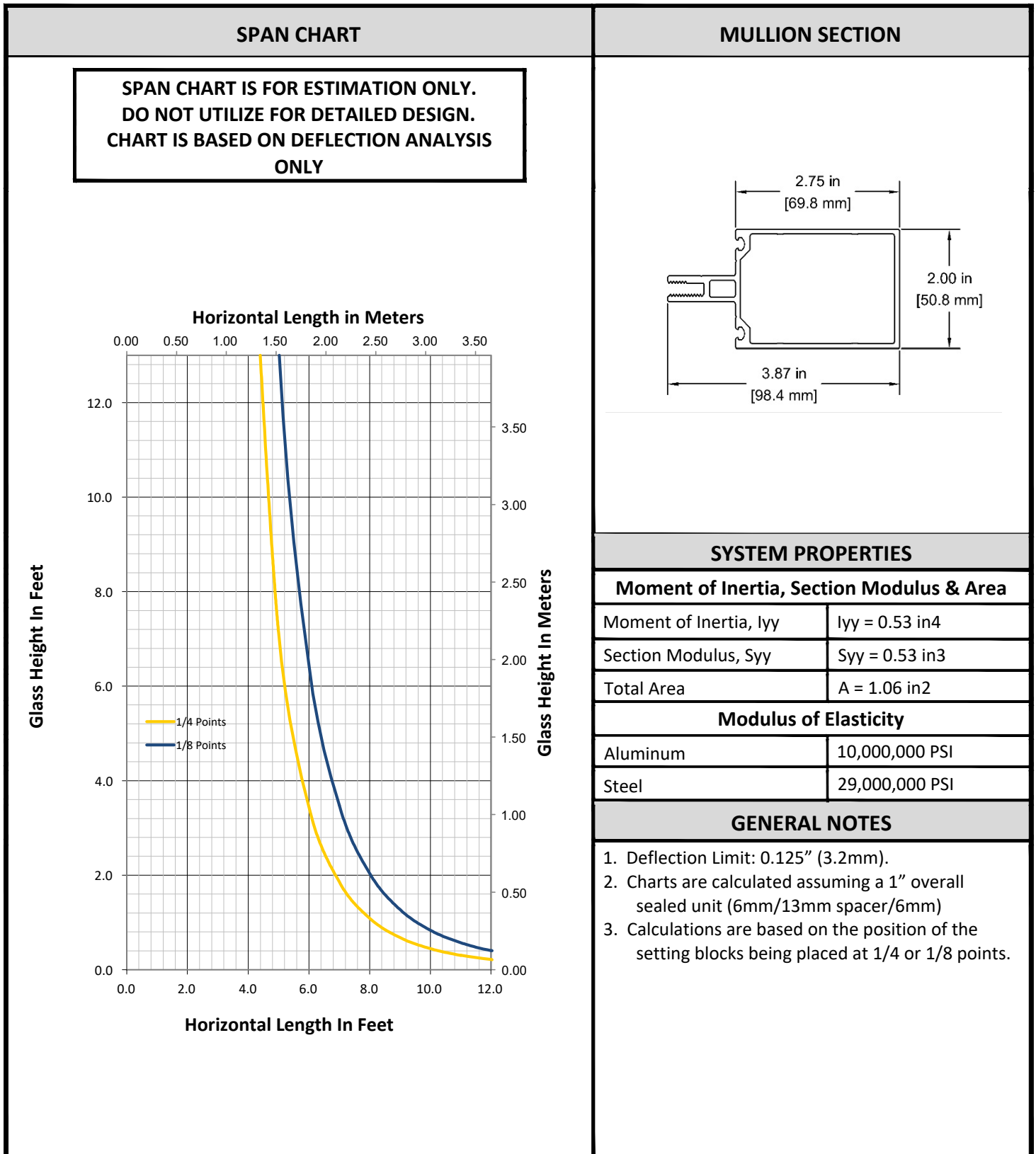

WIND LOAD CHART FOR 2" x 4" MULLION - PART # 2404

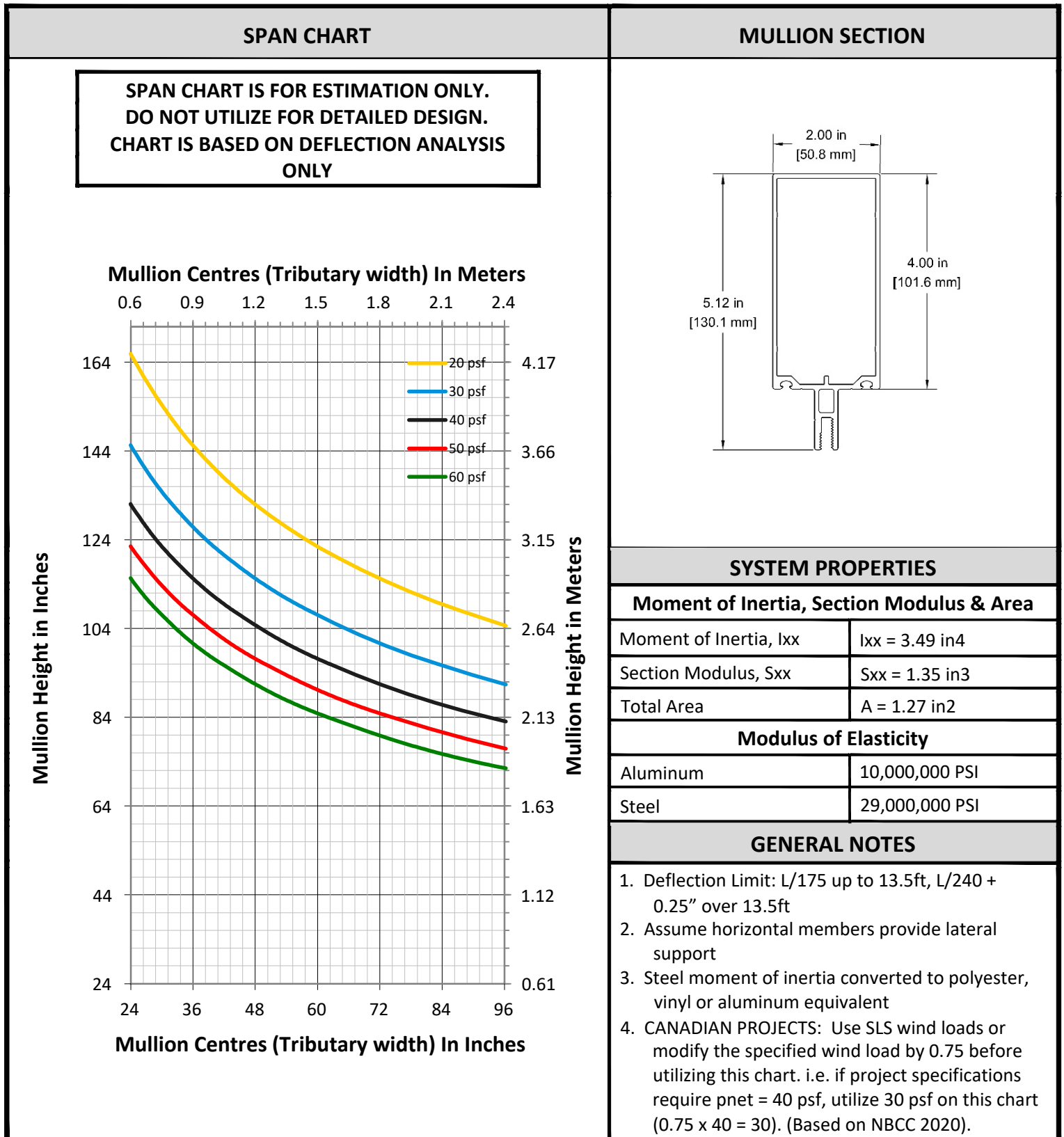

STEEL LOADED WIND LOAD CHART FOR 2" x 4" MULLION - PART # 2404

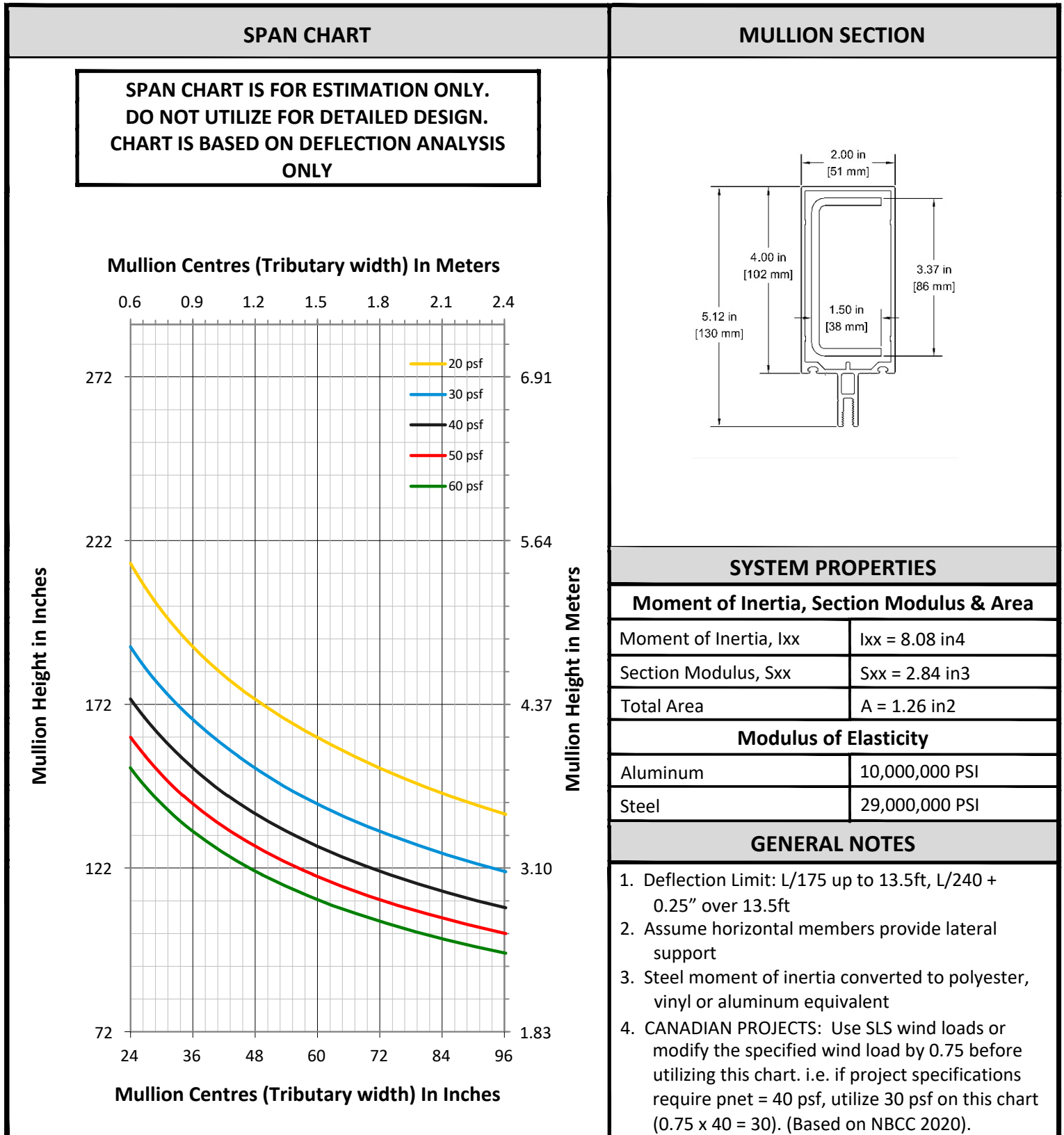

DEAD LOAD CHART FOR 2" x 4" MULLION - PART # 2404

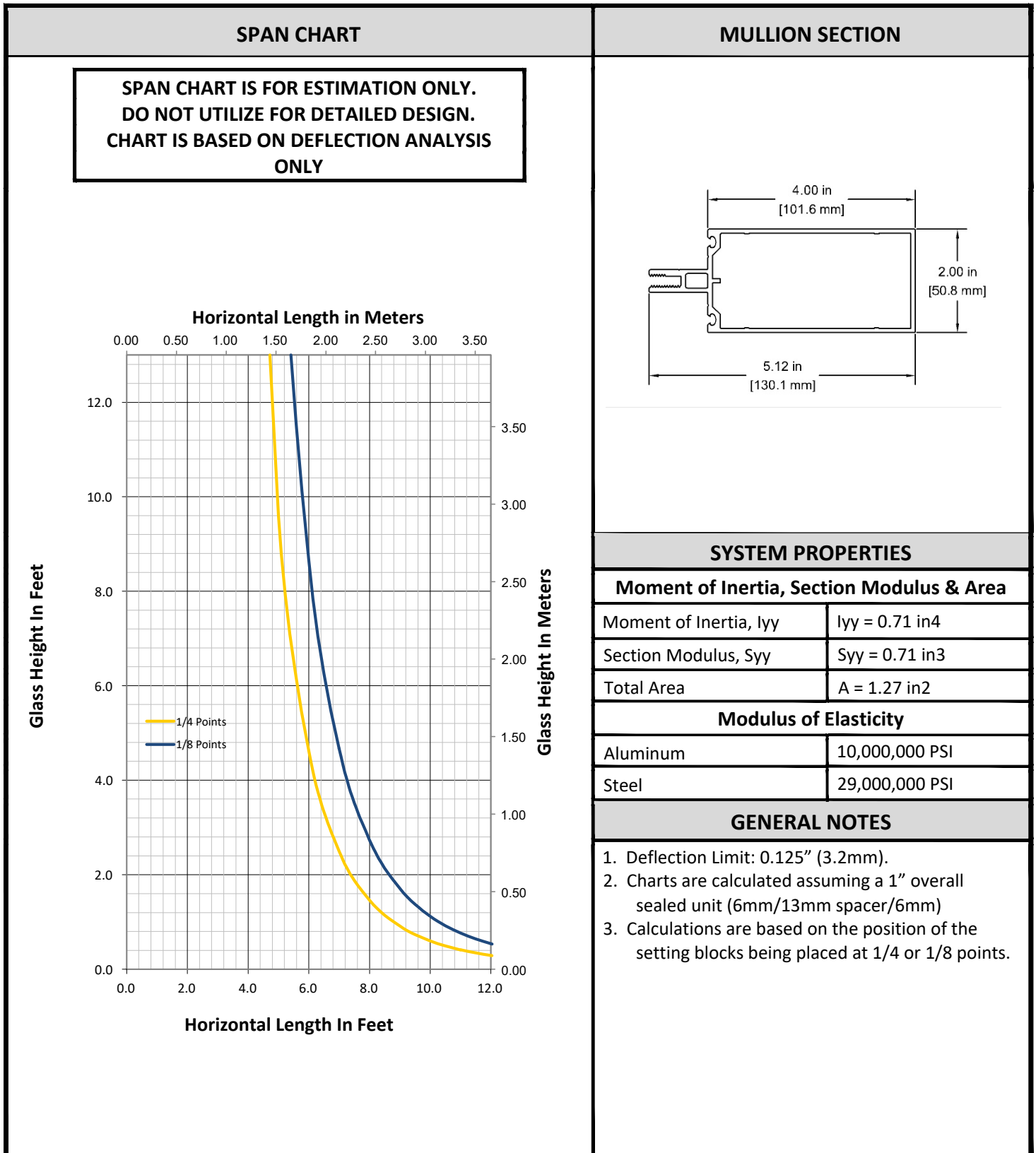

WIND LOAD CHART FOR 2" x 4" SSG MULLION - PART # 2404SSG

SPAN CHART

SPAN CHART IS FOR ESTIMATION ONLY.
DO NOT UTILIZE FOR DETAILED DESIGN.
CHART IS BASED ON DEFLECTION ANALYSIS
ONLY

Mullion Centres (Tributary width) In Meters

0.6 0.9 1.2 1.5 1.8 2.1 2.4

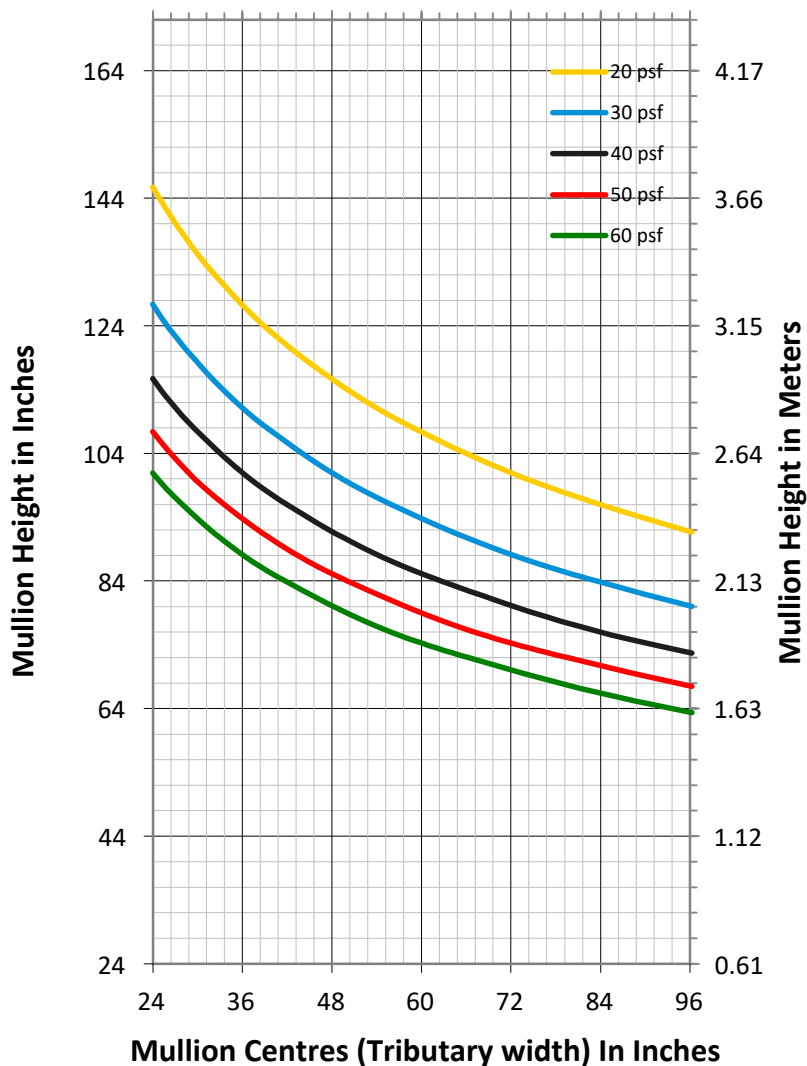

MULLION SECTION

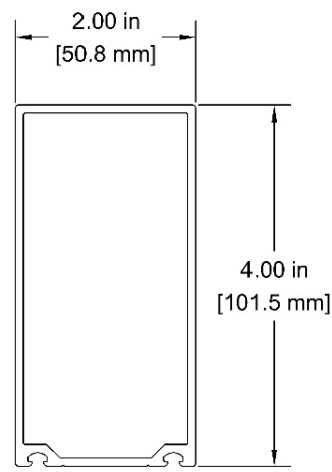

SYSTEM PROPERTIES

Moment of Inertia, Section Modulus & Area

Moment of Inertia, I_{xx}	$I_{xx} = 2.35 \text{ in}^4$
Section Modulus, S_{xx}	$S_{xx} = 1.13 \text{ in}^3$
Total Area	$A = 1.10 \text{ in}^2$

Modulus of Elasticity

Aluminum	10,000,000 PSI
Steel	29,000,000 PSI

GENERAL NOTES

1. Deflection Limit: $L/175$ up to 13.5ft, $L/240 + 0.25"$ over 13.5ft
2. Assume horizontal members provide lateral support
3. Steel moment of inertia converted to polyester, vinyl or aluminum equivalent
4. CANADIAN PROJECTS: Use SLS wind loads or modify the specified wind load by 0.75 before utilizing this chart. i.e. if project specifications require $p_{net} = 40 \text{ psf}$, utilize 30 psf on this chart ($0.75 \times 40 = 30$). (Based on NBCC 2020).

STEEL LOADED WIND LOAD CHART FOR 2" x 4" SSG MULLION - PART # 2404SSG

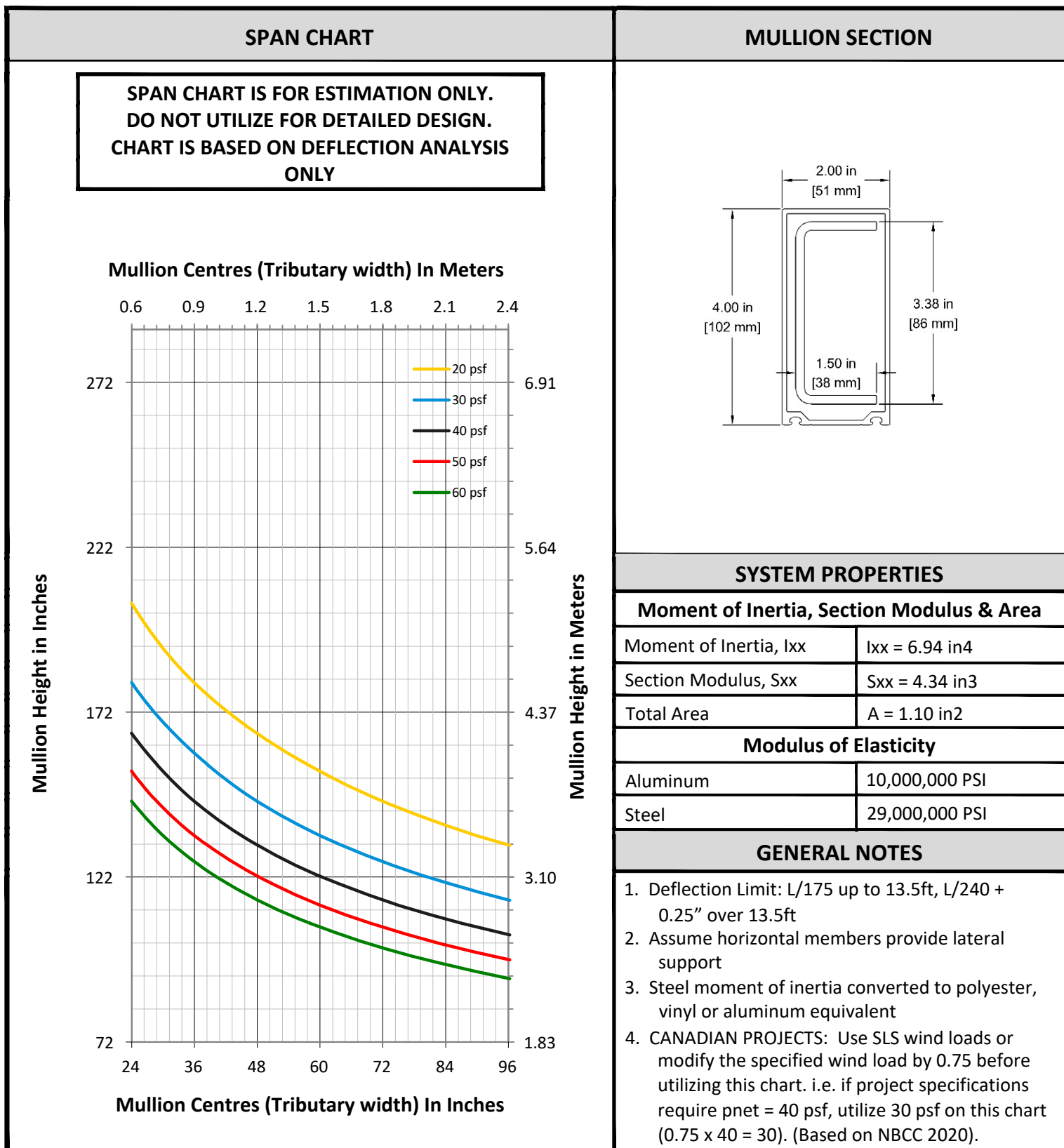

DEAD LOAD CHART FOR 2" x 4" SSG MULLION - PART # 2404SSG

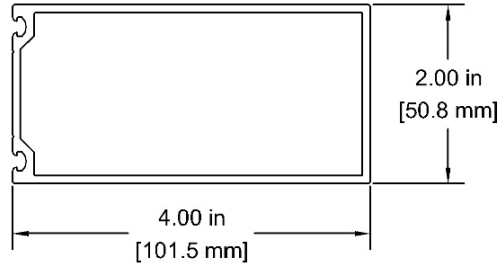
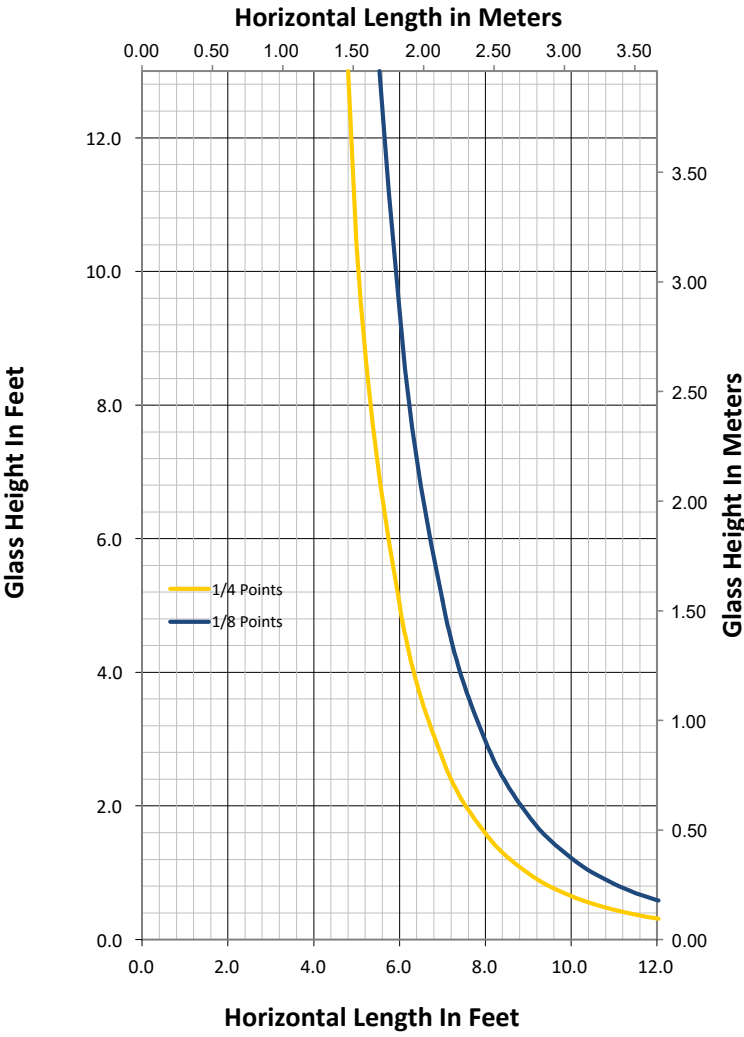
SPAN CHART	MULLION SECTION																				
<p>SPAN CHART IS FOR ESTIMATION ONLY. DO NOT UTILIZE FOR DETAILED DESIGN. CHART IS BASED ON DEFLECTION ANALYSIS ONLY</p>																					
	<table border="1" style="width: 100%; border-collapse: collapse;"> <thead> <tr style="background-color: #cccccc;"> <th colspan="2" style="text-align: center;">SYSTEM PROPERTIES</th> </tr> </thead> <tbody> <tr style="background-color: #cccccc;"> <th colspan="2" style="text-align: center;">Moment of Inertia, Section Modulus & Area</th> </tr> <tr> <td style="text-align: left;">Moment of Inertia, I_{yy}</td> <td style="text-align: right;">$I_{yy} = 0.77 \text{ in}^4$</td> </tr> <tr> <td style="text-align: left;">Section Modulus, S_{yy}</td> <td style="text-align: right;">$S_{yy} = 0.77 \text{ in}^3$</td> </tr> <tr> <td style="text-align: left;">Total Area</td> <td style="text-align: right;">$A = 1.10 \text{ in}^2$</td> </tr> <tr style="background-color: #cccccc;"> <th colspan="2" style="text-align: center;">Modulus of Elasticity</th> </tr> <tr> <td style="text-align: left;">Aluminum</td> <td style="text-align: right;">10,000,000 PSI</td> </tr> <tr> <td style="text-align: left;">Steel</td> <td style="text-align: right;">29,000,000 PSI</td> </tr> <tr style="background-color: #cccccc;"> <th colspan="2" style="text-align: center;">GENERAL NOTES</th> </tr> <tr> <td colspan="2"> <ol style="list-style-type: none"> 1. Deflection Limit: 0.125" (3.2mm). 2. Charts are calculated assuming a 1" overall sealed unit (6mm/13mm spacer/6mm) 3. Calculations are based on the position of the setting blocks being placed at 1/4 or 1/8 points. </td> </tr> </tbody> </table>	SYSTEM PROPERTIES		Moment of Inertia, Section Modulus & Area		Moment of Inertia, I_{yy}	$I_{yy} = 0.77 \text{ in}^4$	Section Modulus, S_{yy}	$S_{yy} = 0.77 \text{ in}^3$	Total Area	$A = 1.10 \text{ in}^2$	Modulus of Elasticity		Aluminum	10,000,000 PSI	Steel	29,000,000 PSI	GENERAL NOTES		<ol style="list-style-type: none"> 1. Deflection Limit: 0.125" (3.2mm). 2. Charts are calculated assuming a 1" overall sealed unit (6mm/13mm spacer/6mm) 3. Calculations are based on the position of the setting blocks being placed at 1/4 or 1/8 points. 	
SYSTEM PROPERTIES																					
Moment of Inertia, Section Modulus & Area																					
Moment of Inertia, I_{yy}	$I_{yy} = 0.77 \text{ in}^4$																				
Section Modulus, S_{yy}	$S_{yy} = 0.77 \text{ in}^3$																				
Total Area	$A = 1.10 \text{ in}^2$																				
Modulus of Elasticity																					
Aluminum	10,000,000 PSI																				
Steel	29,000,000 PSI																				
GENERAL NOTES																					
<ol style="list-style-type: none"> 1. Deflection Limit: 0.125" (3.2mm). 2. Charts are calculated assuming a 1" overall sealed unit (6mm/13mm spacer/6mm) 3. Calculations are based on the position of the setting blocks being placed at 1/4 or 1/8 points. 																					

WIND LOAD CHART FOR 2" x 4" SPLIT MULLION - PART # 2414/2441

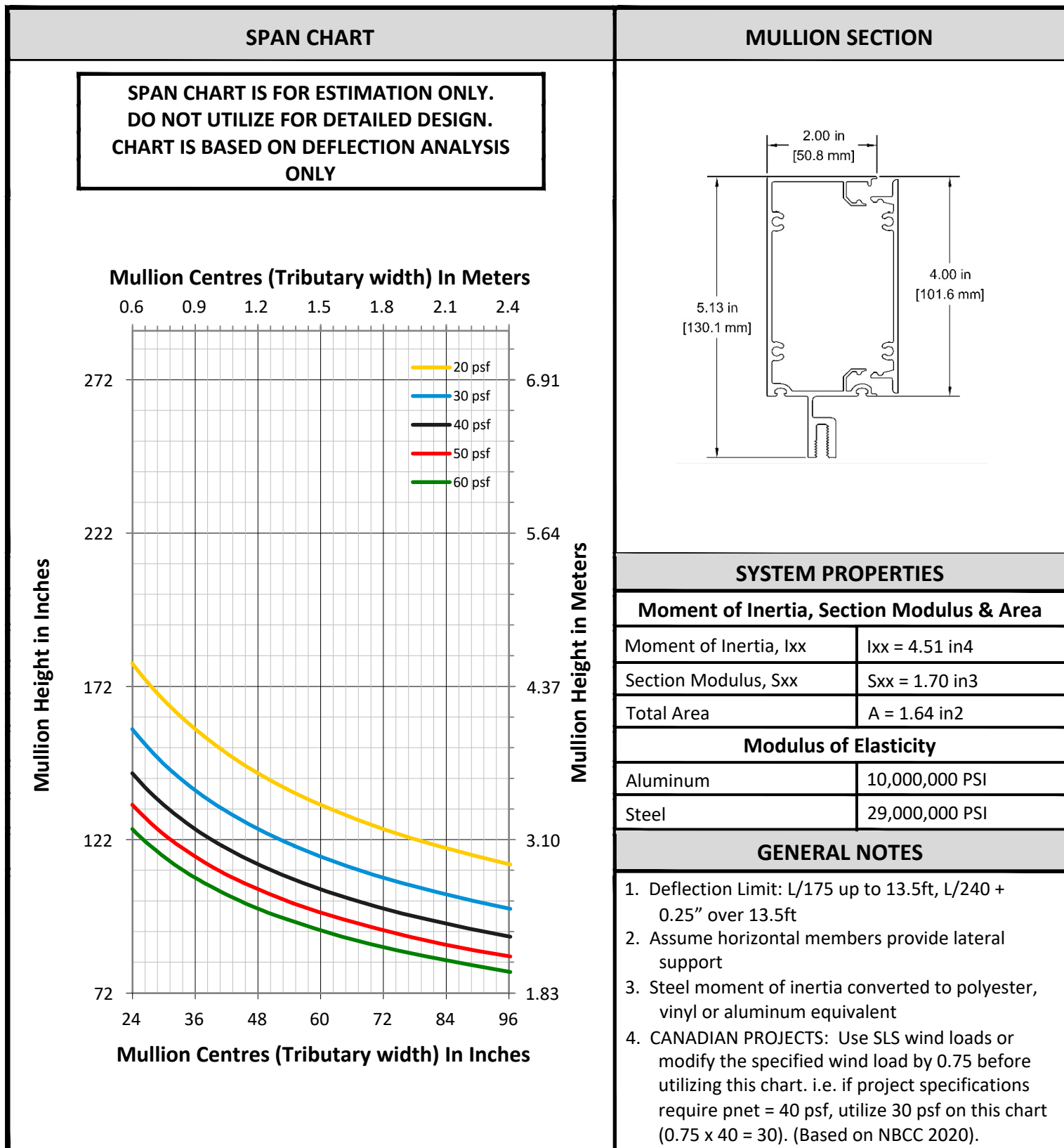

STEEL LOADED WIND LOAD CHART FOR 2" x 4" SPLIT MULLION - PART # 2414/2441

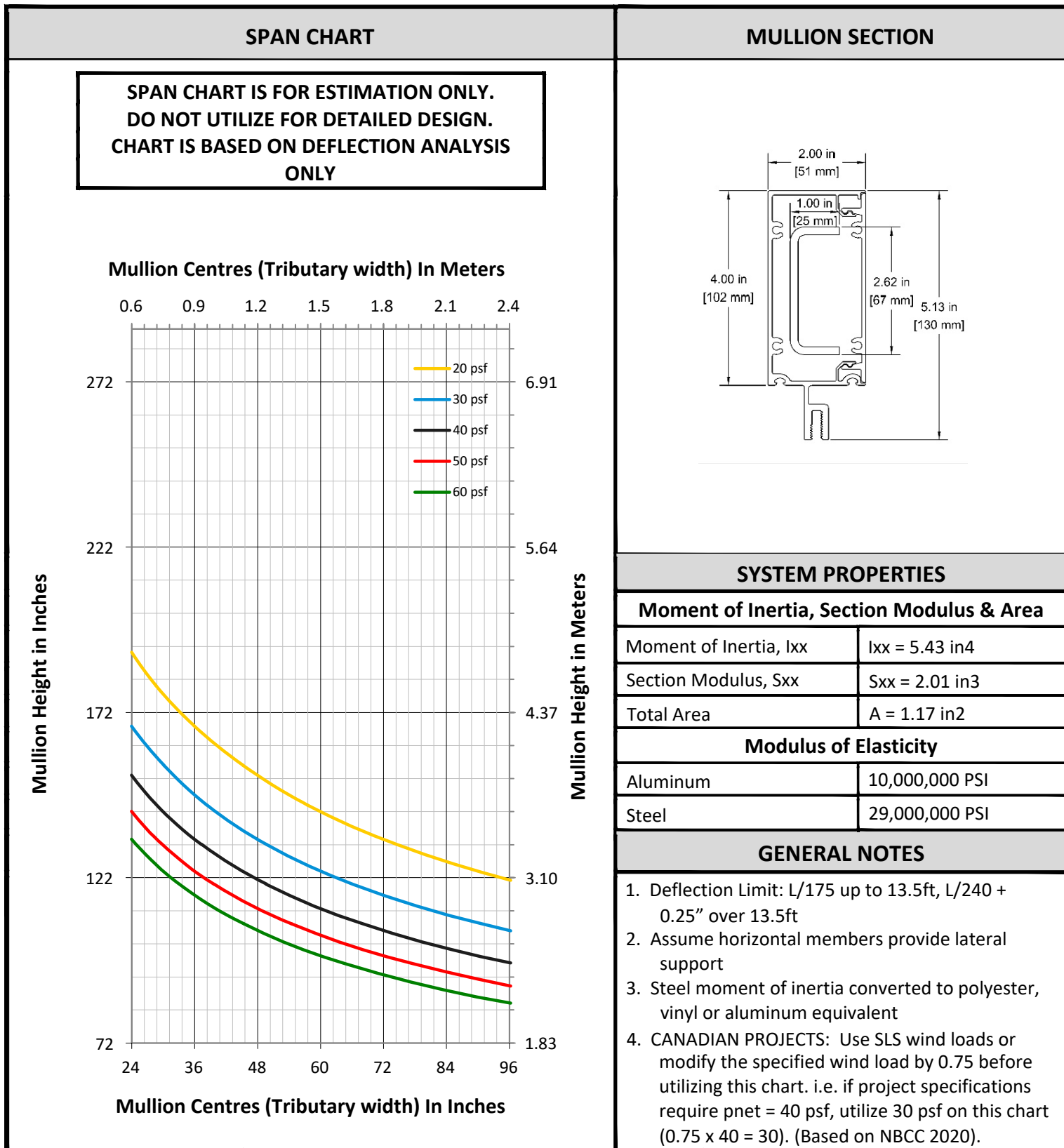

DEAD LOAD CHART FOR 2" x 4" SPLIT MULLION - PART # 2414/2441

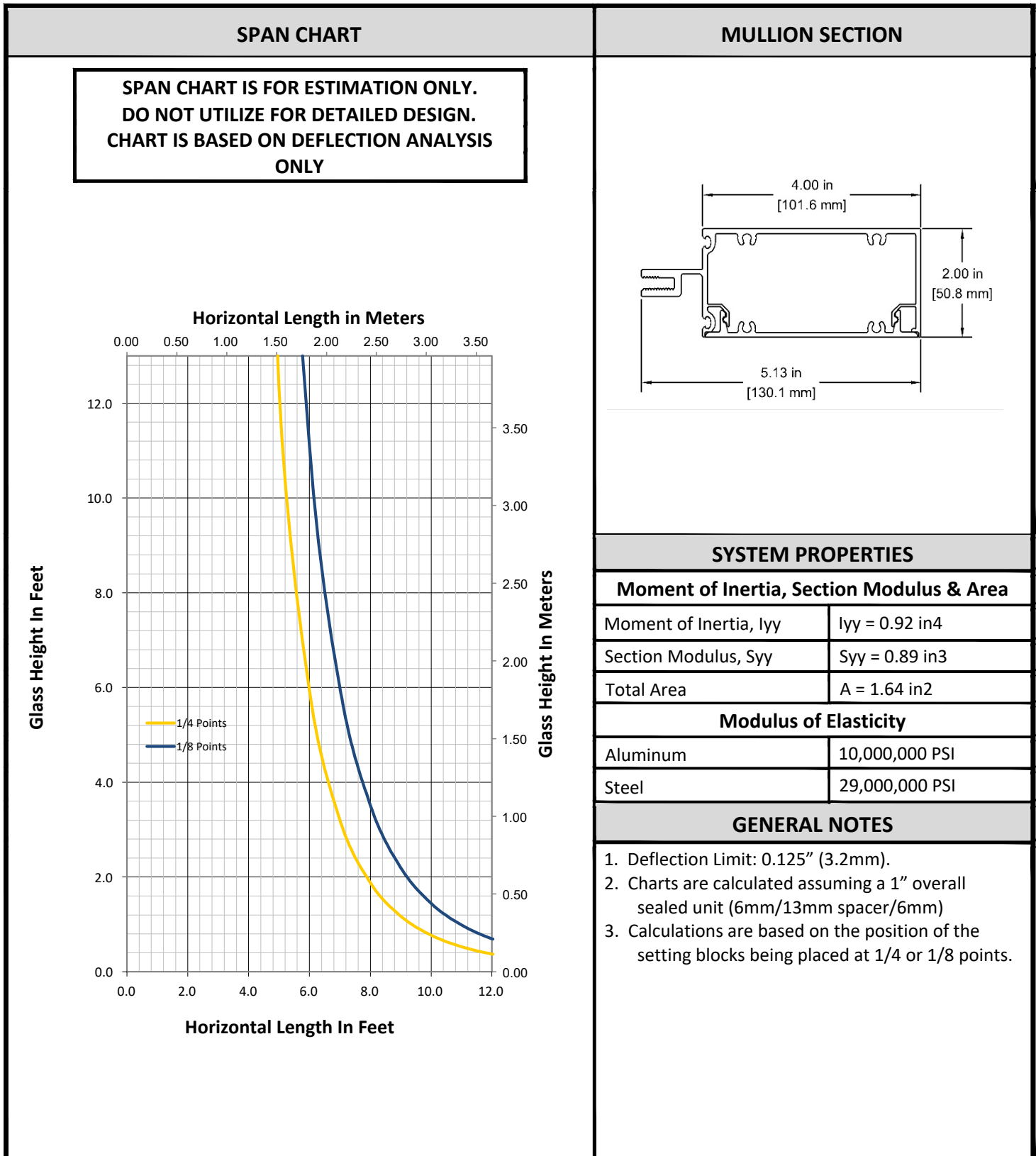

WIND LOAD CHART FOR 2" x 5 1/4" MULLION - PART # 2425S

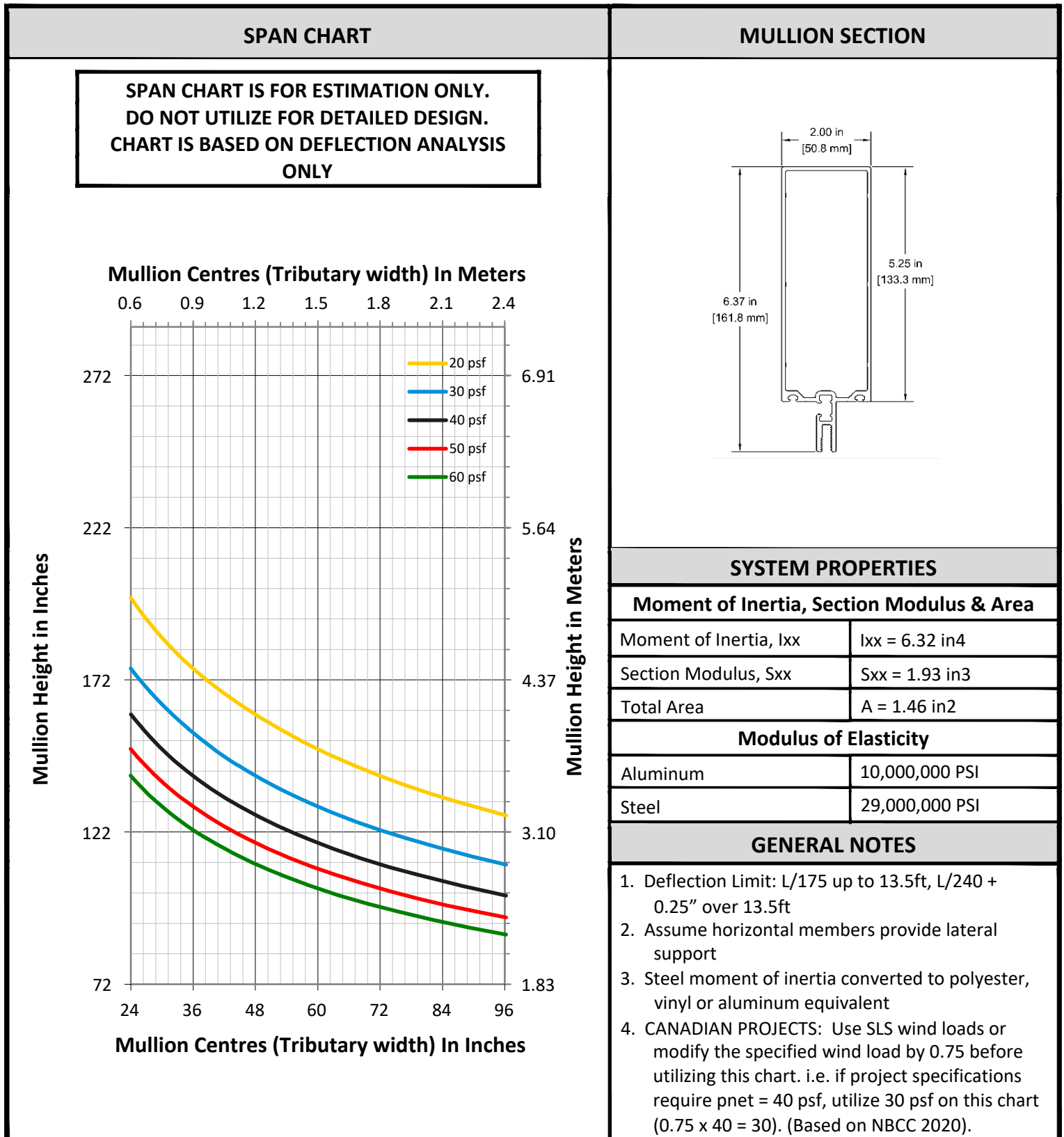

STEEL LOADED WIND LOAD CHART FOR 2" x 5 1/4" MULLION - PART # 2425S

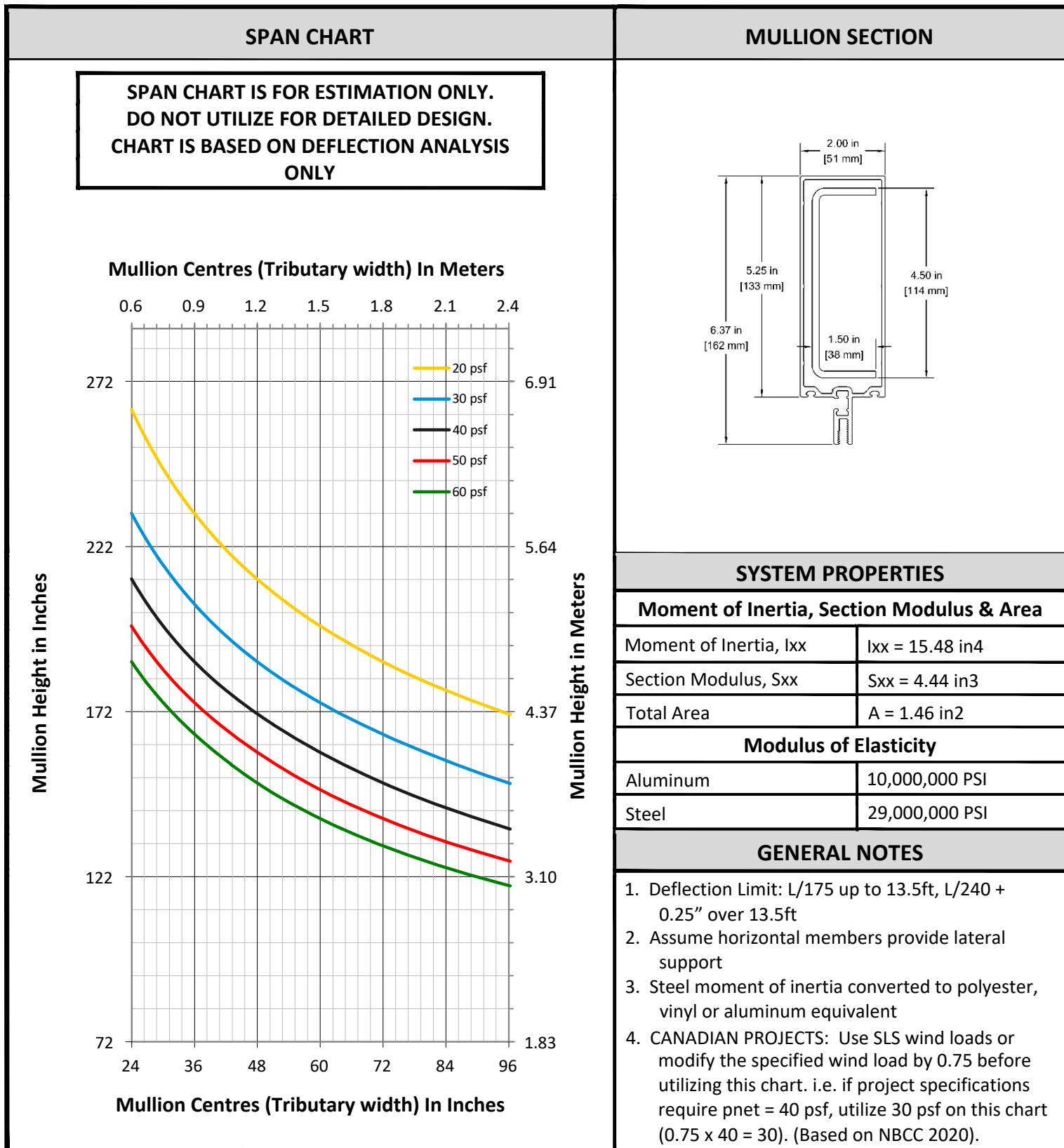

DEAD LOAD CHART FOR 2" x 5 1/4" MULLION - PART # 2425S

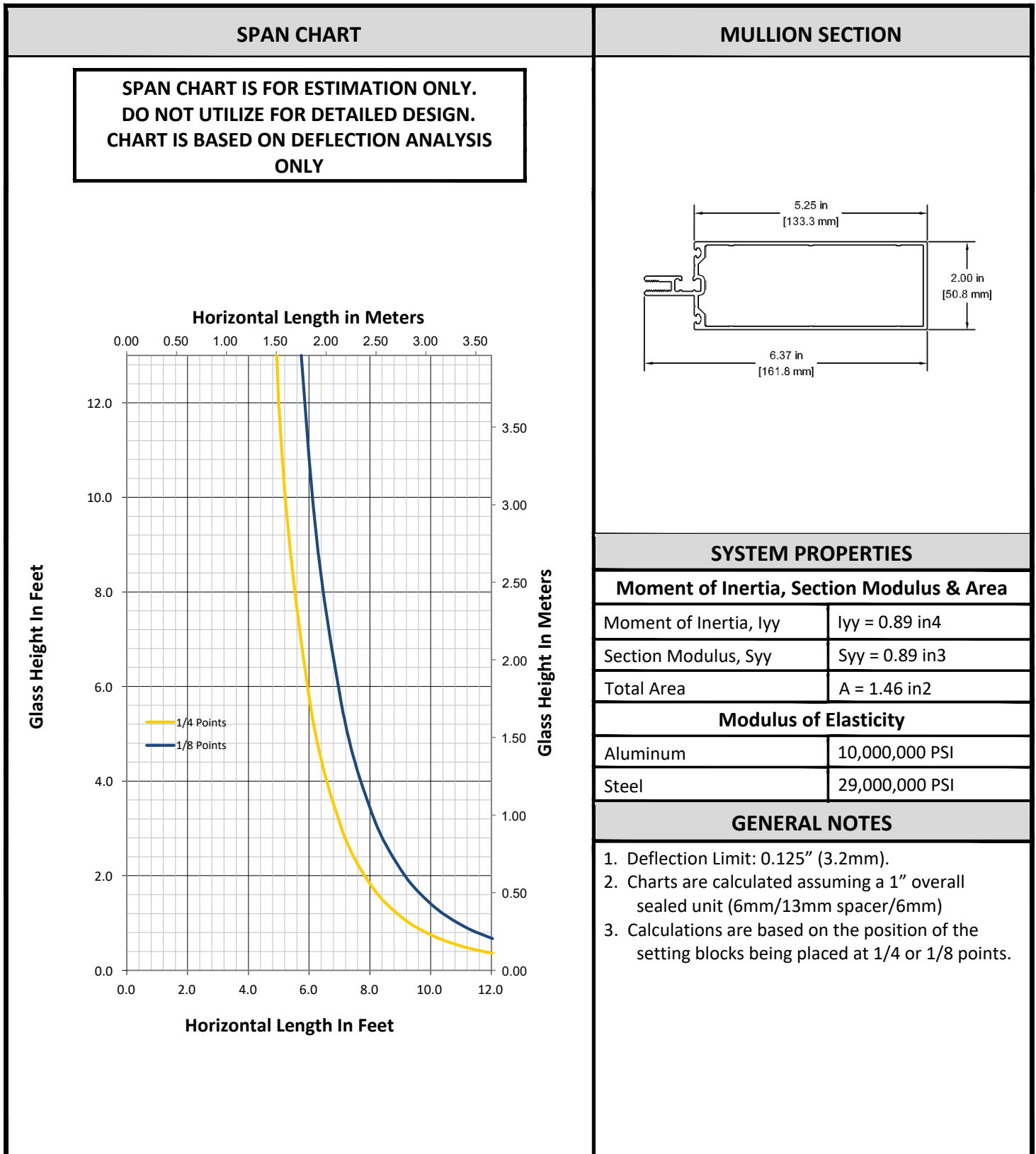

WIND LOAD CHART FOR 2" x 6" MULLION - PART # 2426S

SPAN CHART

SPAN CHART IS FOR ESTIMATION ONLY.
DO NOT UTILIZE FOR DETAILED DESIGN.
CHART IS BASED ON DEFLECTION ANALYSIS
ONLY

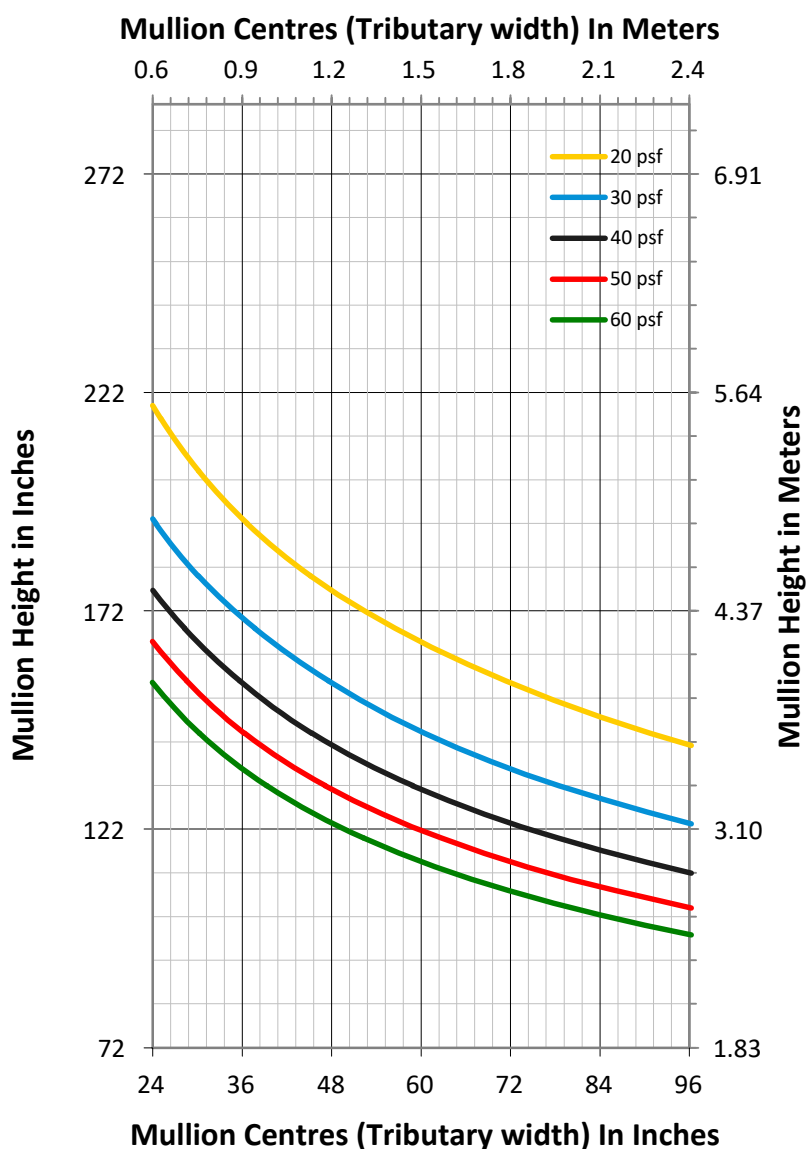

MULLION SECTION

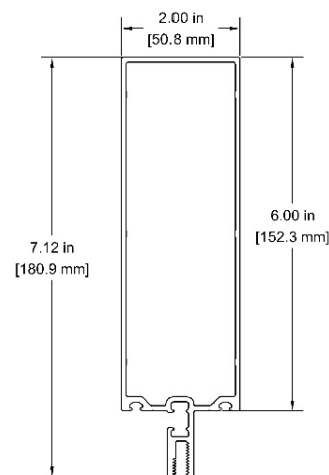

SYSTEM PROPERTIES

Moment of Inertia, Section Modulus & Area

Moment of Inertia, I _{xx}	I _{xx} = 8.57 in ⁴
Section Modulus, S _{xx}	S _{xx} = 2.33 in ³
Total Area	A = 1.58 in ²

Modulus of Elasticity

Aluminum	10,000,000 PSI
Steel	29,000,000 PSI

GENERAL NOTES

1. Deflection Limit: L/175 up to 13.5ft, L/240 + 0.25" over 13.5ft
2. Assume horizontal members provide lateral support
3. Steel moment of inertia converted to polyester, vinyl or aluminum equivalent
4. CANADIAN PROJECTS: Use SLS wind loads or modify the specified wind load by 0.75 before utilizing this chart. i.e. if project specifications require pnet = 40 psf, utilize 30 psf on this chart (0.75 x 40 = 30). (Based on NBCC 2020).

STEEL LOADED WIND LOAD CHART FOR 2" x 6" MULLION - PART # 2426S

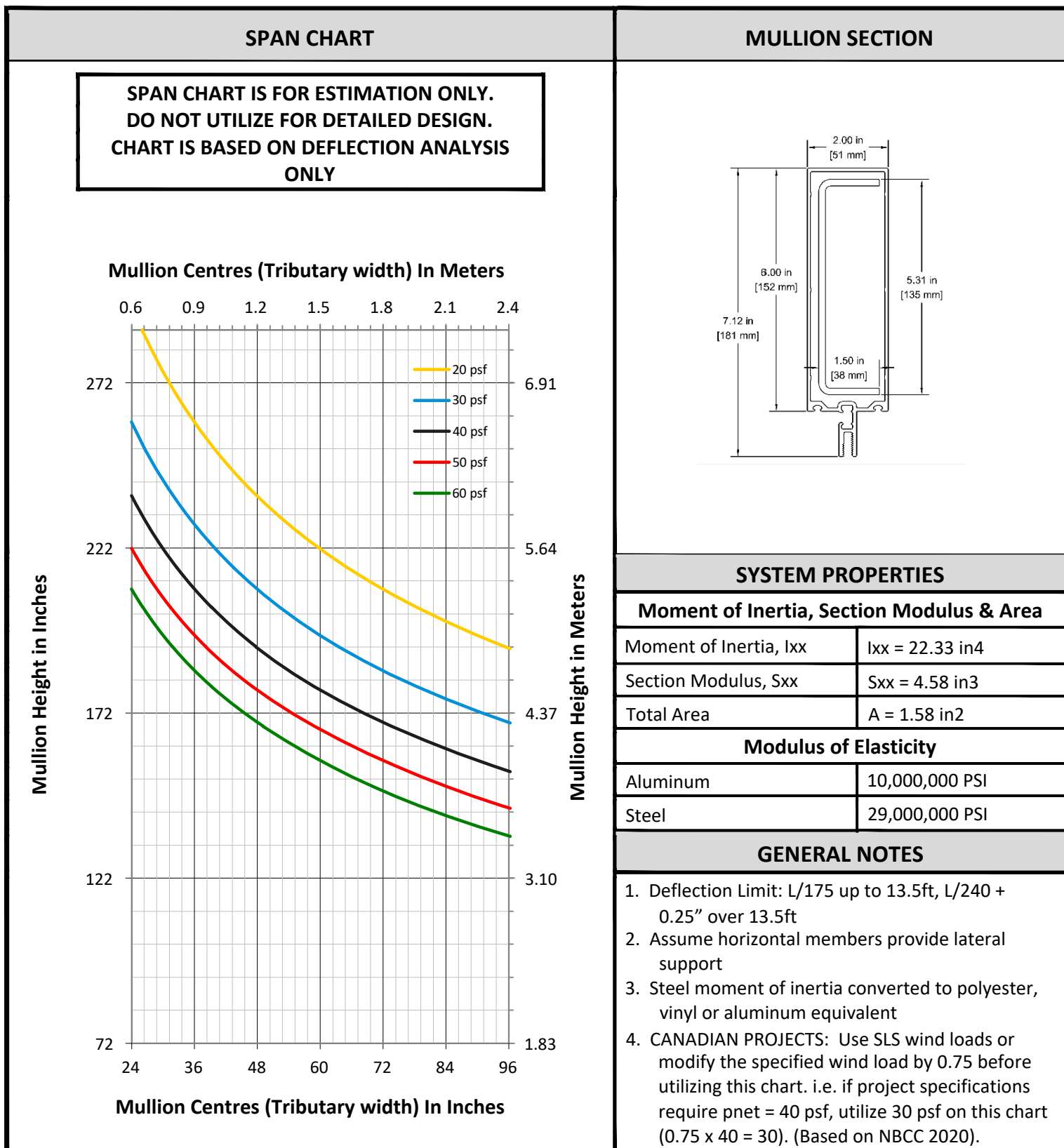

DEAD LOAD CHART FOR 2" x 6" MULLION - PART # 2426S

SPAN CHART

**SPAN CHART IS FOR ESTIMATION ONLY.
DO NOT UTILIZE FOR DETAILED DESIGN.
CHART IS BASED ON DEFLECTION ANALYSIS
ONLY**

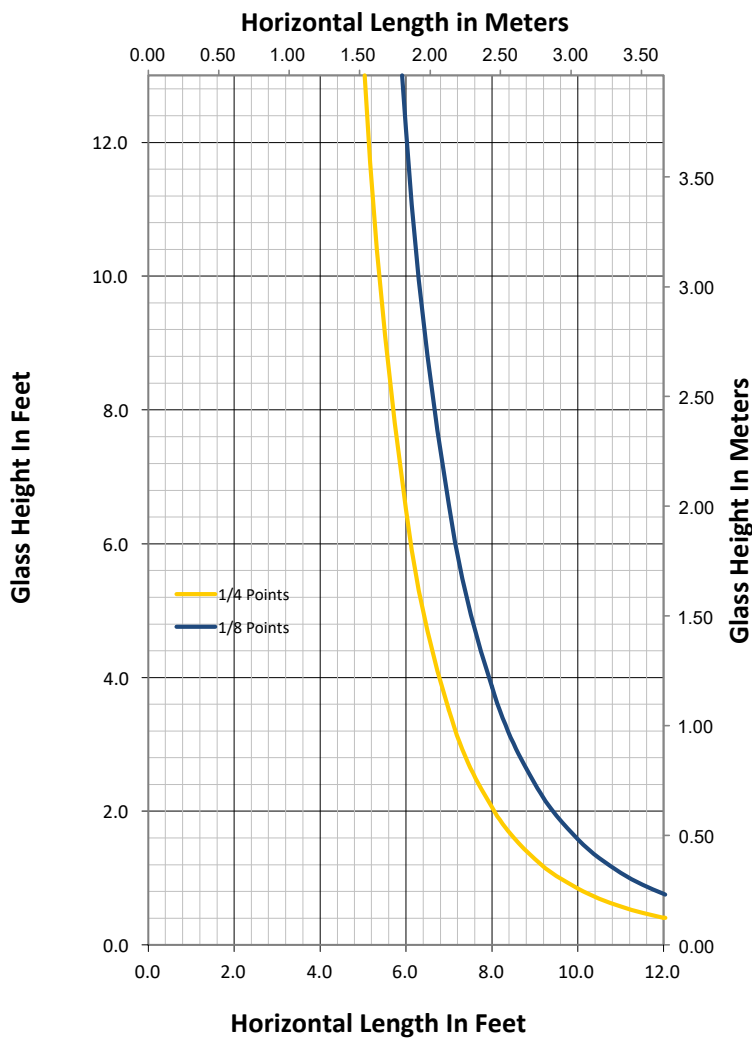

MULLION SECTION

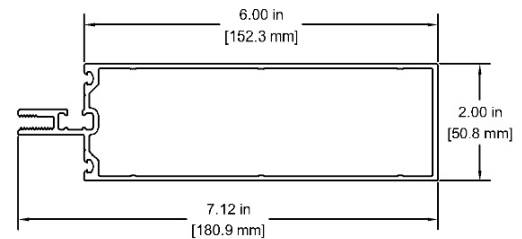

SYSTEM PROPERTIES

Moment of Inertia, Section Modulus & Area

Moment of Inertia, I_{yy}	$I_{yy} = 1.00 \text{ in}^4$
Section Modulus, S_{yy}	$S_{yy} = 1.00 \text{ in}^3$
Total Area	$A = 1.58 \text{ in}^2$

Modulus of Elasticity

Aluminum	10,000,000 PSI
Steel	29,000,000 PSI

GENERAL NOTES

1. Deflection Limit: 0.125" (3.2mm).
2. Charts are calculated assuming a 1" overall sealed unit (6mm/13mm spacer/6mm)
3. Calculations are based on the position of the setting blocks being placed at 1/4 or 1/8 points.



**METRO
ALUMINUM**

Products Ltd.

2400T SERIES

THERMALLY BROKEN
CURTAIN WALL & WINDOW SYSTEM
NARROW - 2" (50.8 mm) - FRAME

D

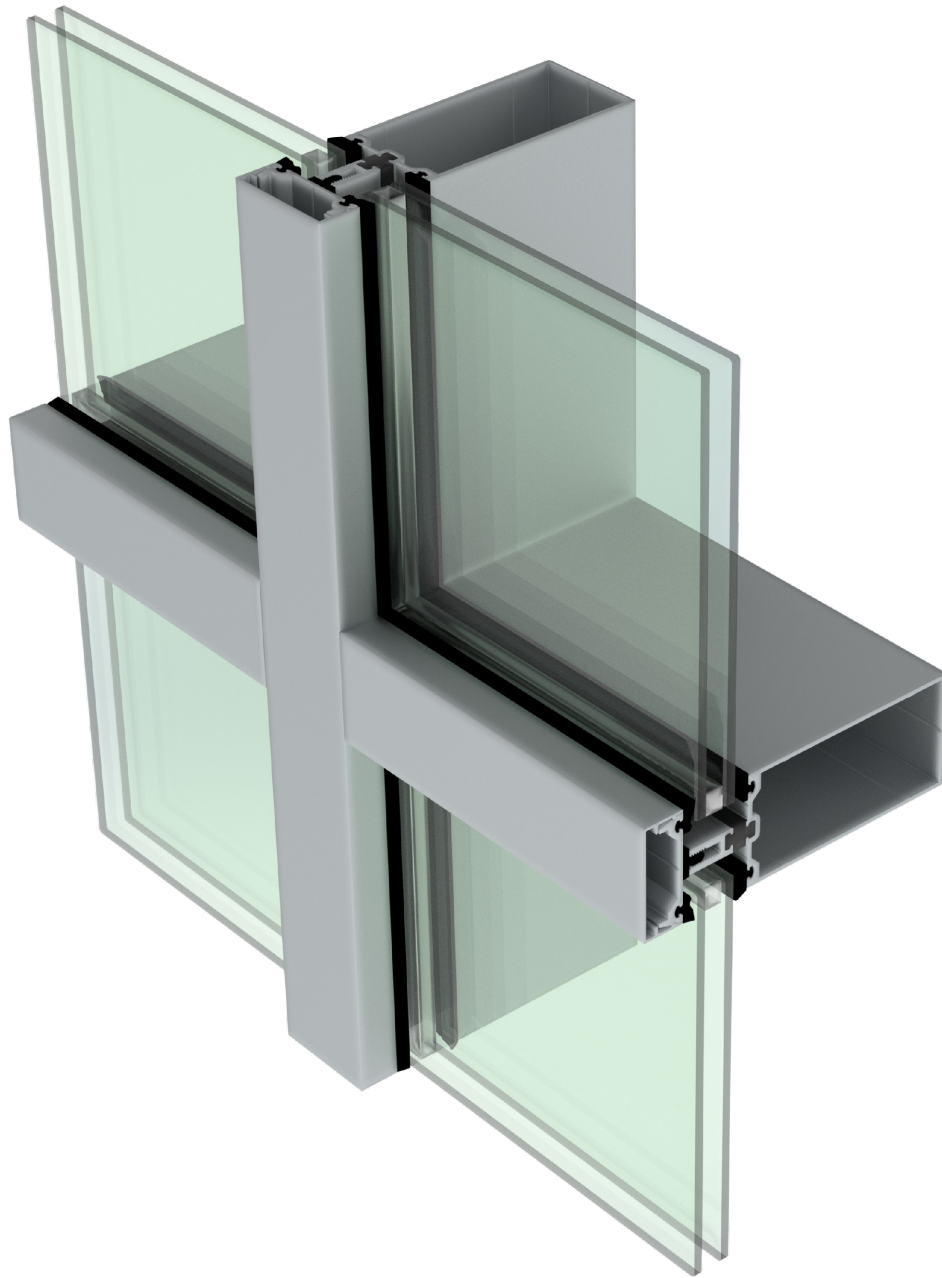



BACK SECTIONS & CAPS

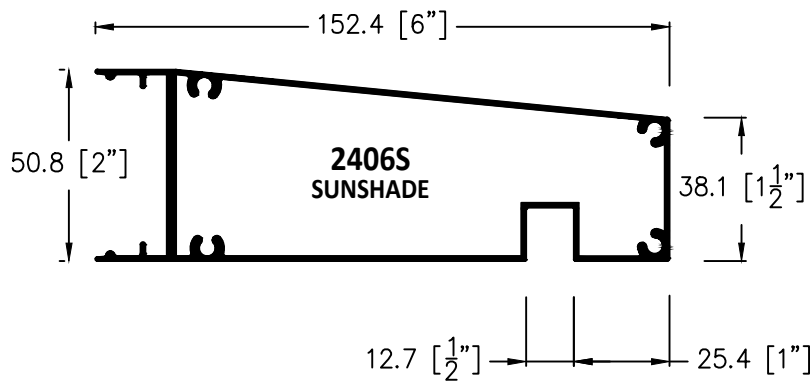
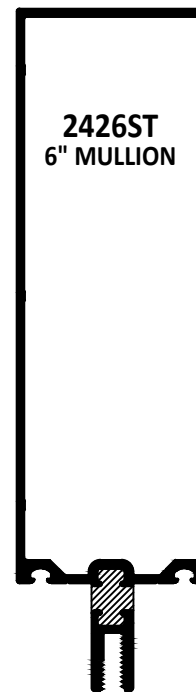
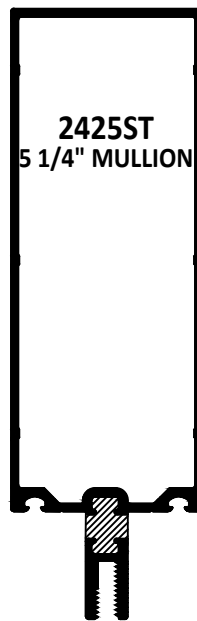
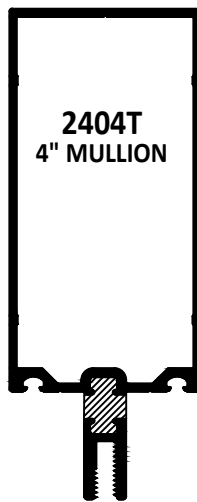
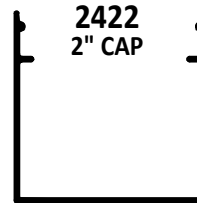
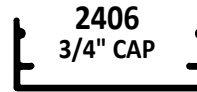
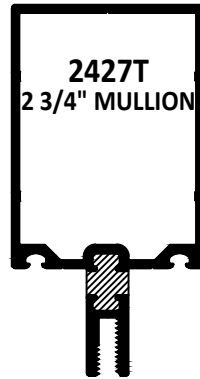
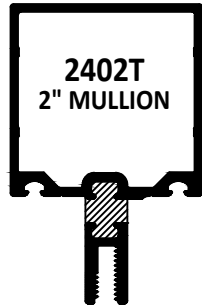



**METRO
ALUMINUM**
Products Ltd.

2400T SERIES

THERMALLY BROKEN
CURTAIN WALL & WINDOW SYSTEM
NARROW - 2" (50.8 mm) - FRAME

**D
16**

SSG & CORNERS

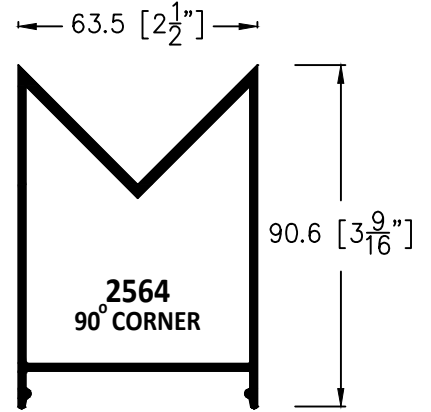
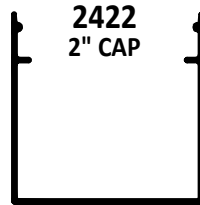

EXTENSION CAP FOR 4" BACK

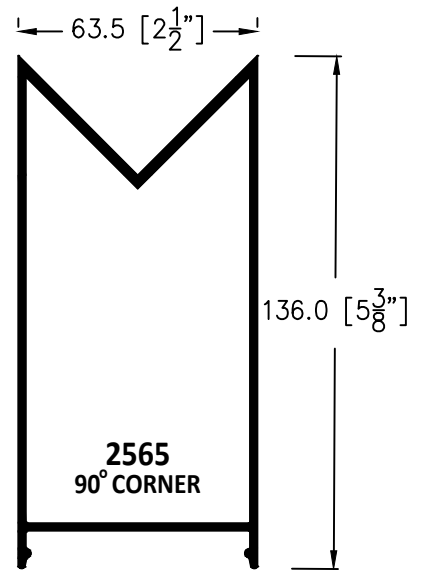
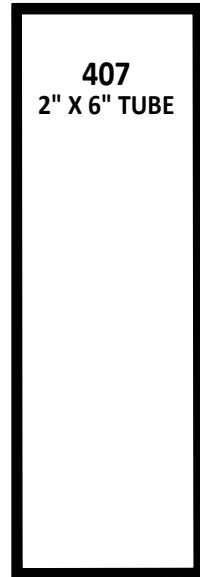
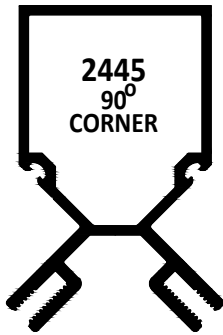

EXTENSION CAP FOR 5 1/4" BACK

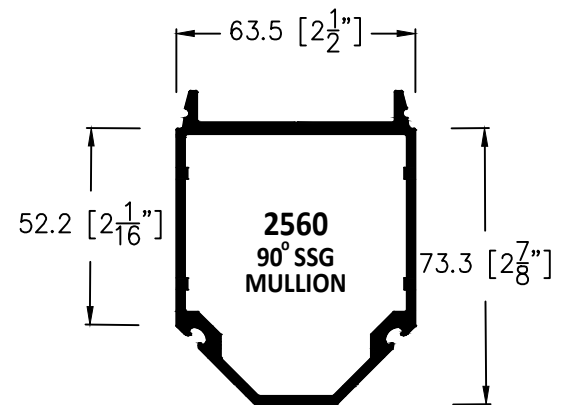
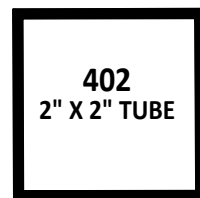
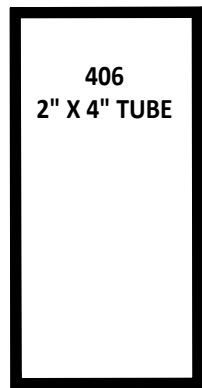



MISC. COMPONENTS

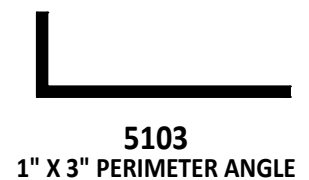
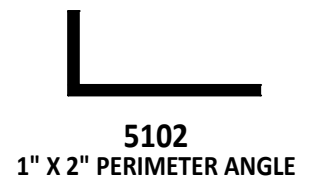
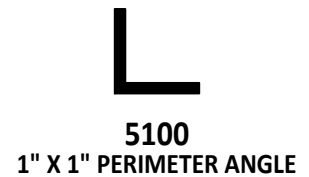
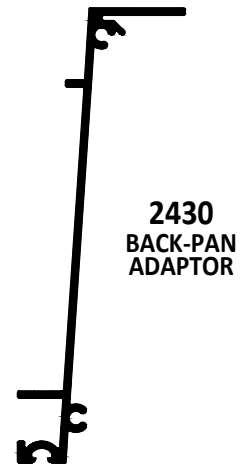
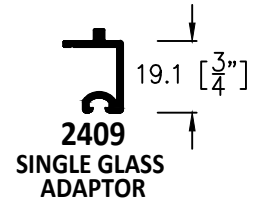
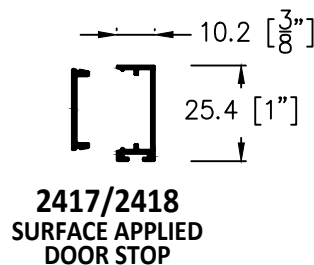
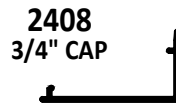
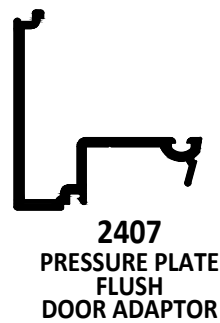
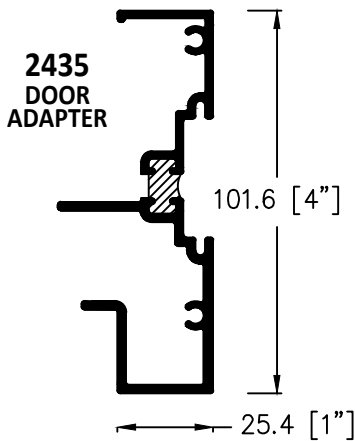
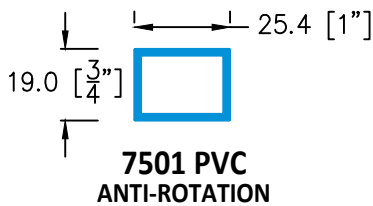



TYPICAL DETAILS

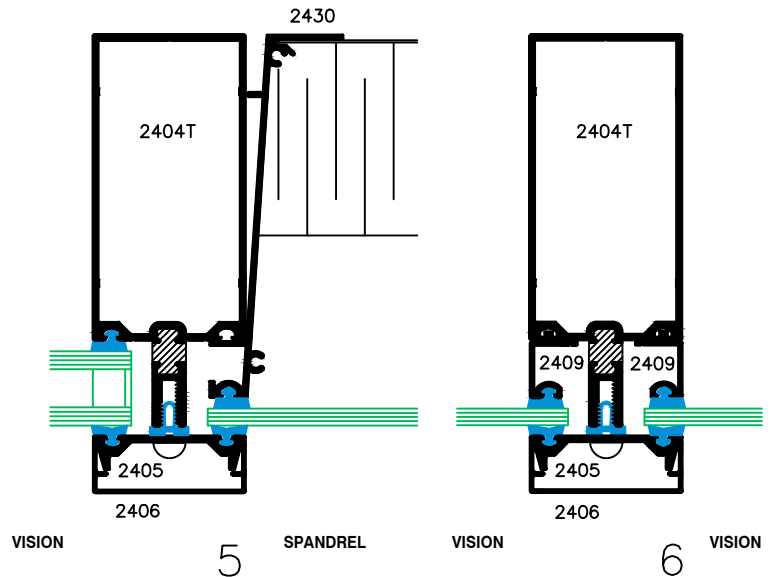
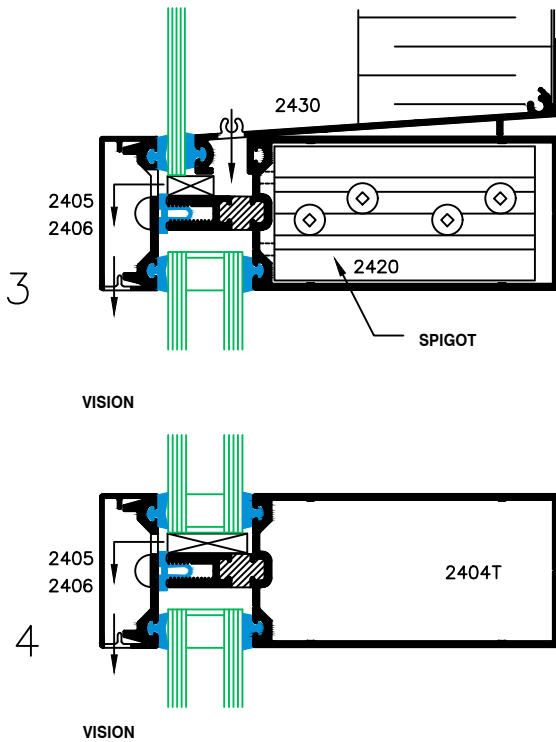
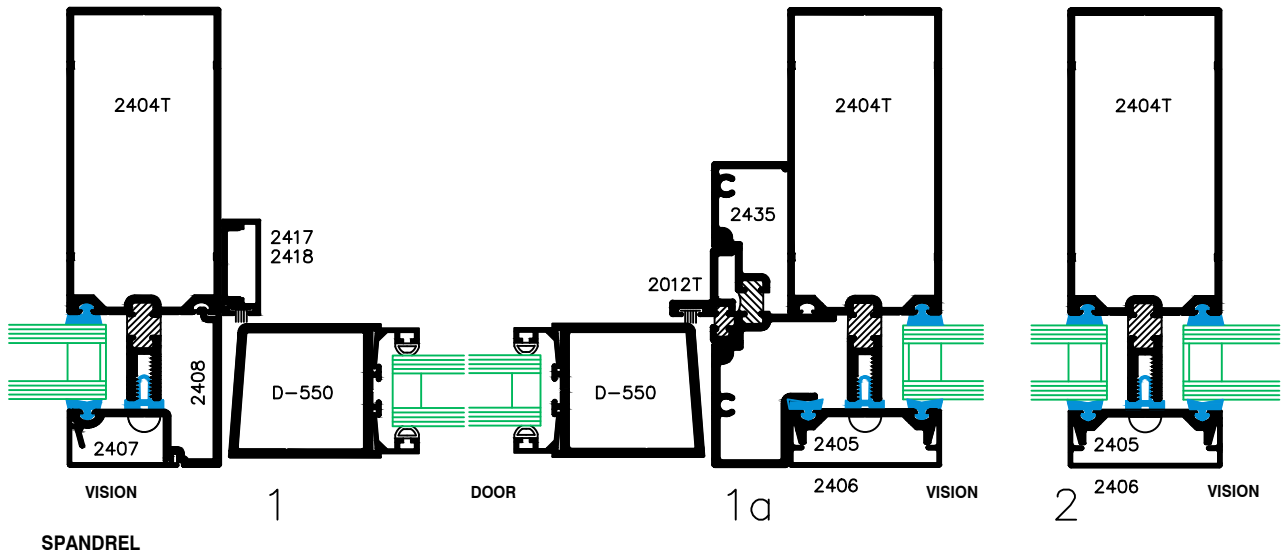

TYPICAL CURTAIN WALL DETAILS

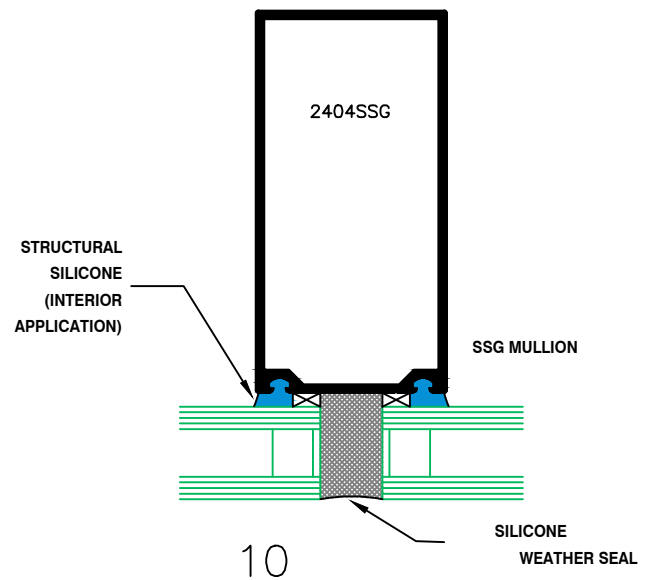
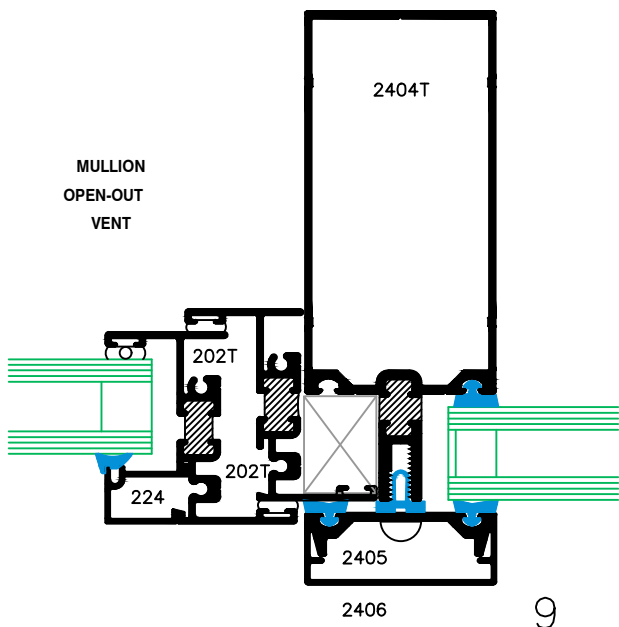
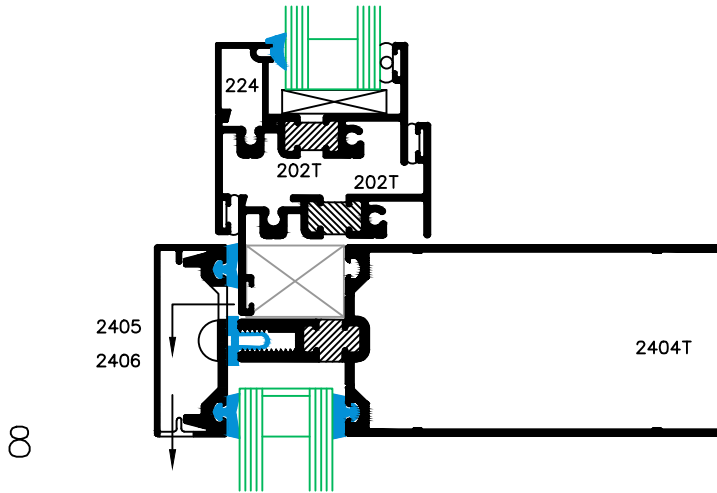
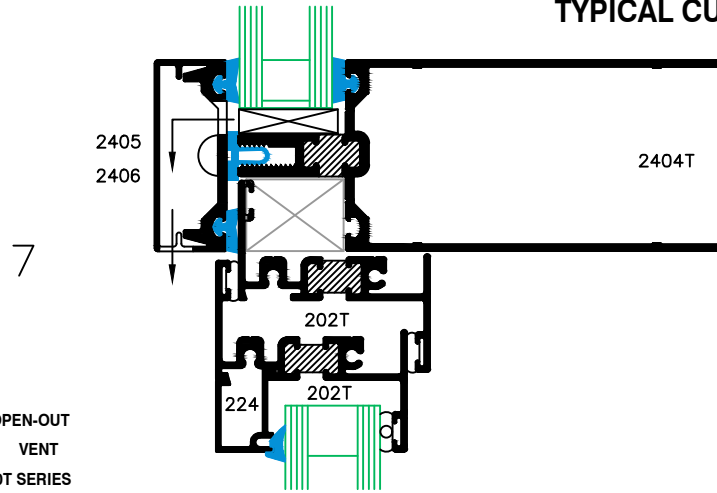



TYPICAL CAPTURED CORNER DETAILS

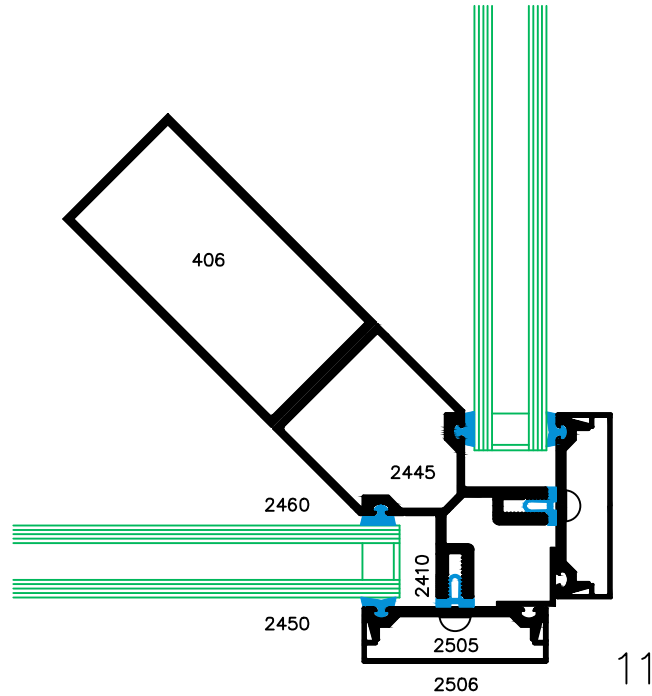

11

90° CAPTURED CORNER

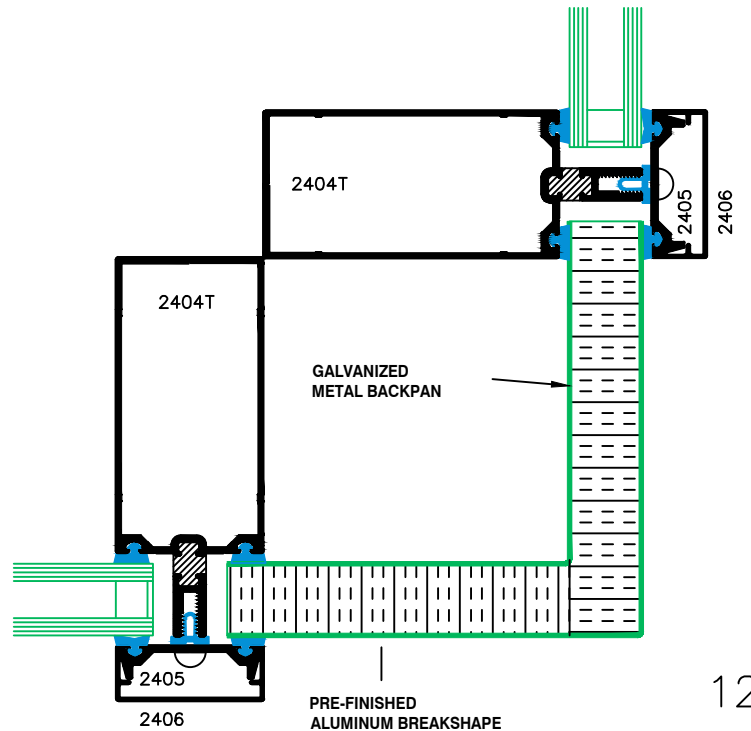

12

90° BREAKSHAPE CORNER



TYPICAL BUTT-JOINT CORNER DETAILS

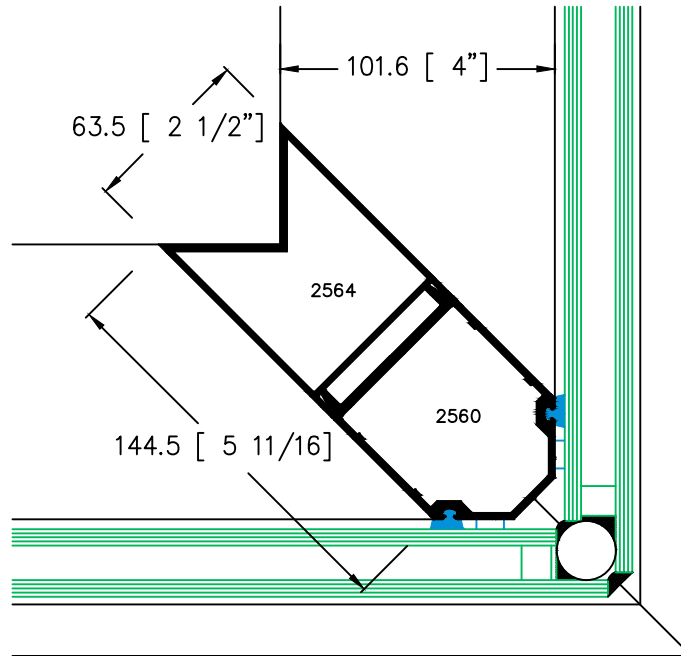

90° BUTT-JOINT CORNER
AT 4" BACK MEMBER

13

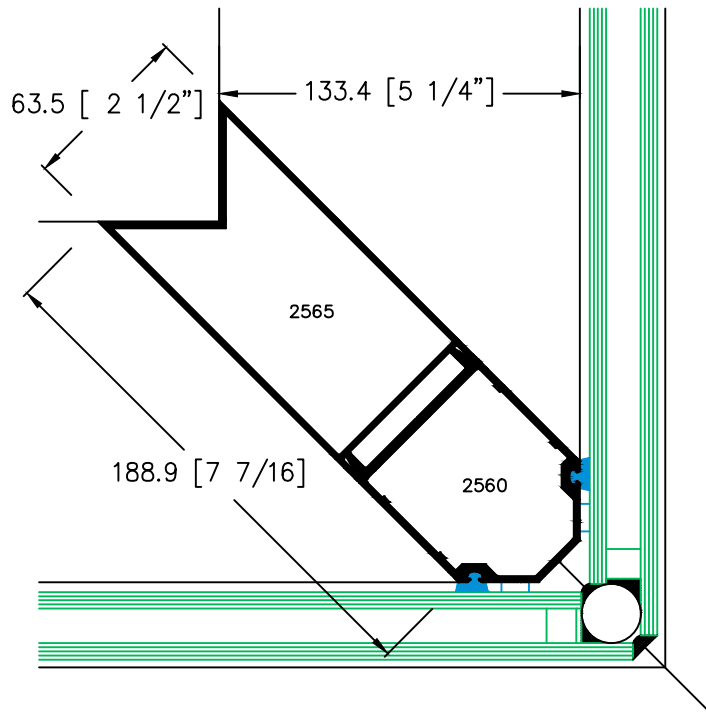

90° BUTT-JOINT CORNER
AT 5 1/4" BACK MEMBER

14

ALTERNATE DOOR DETAILS

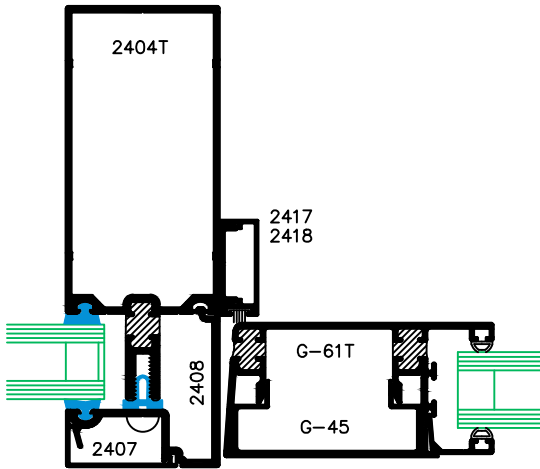

GLACIER DOOR

15

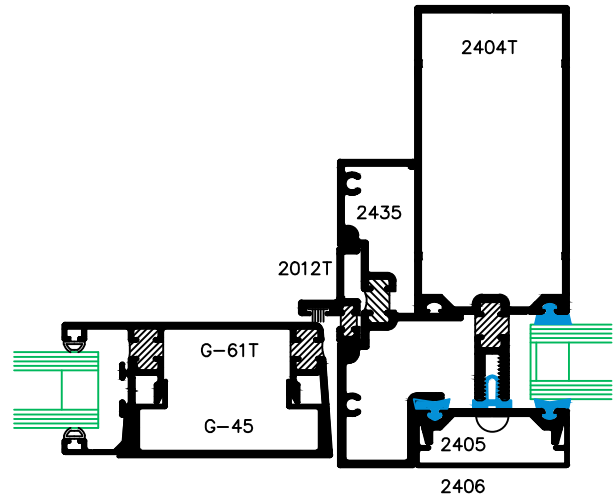

SWING DOORS

15a

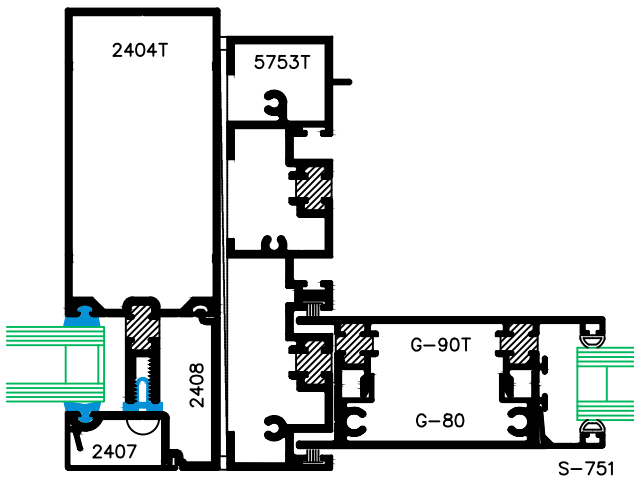

1100T JAMB AT SLIDER

16

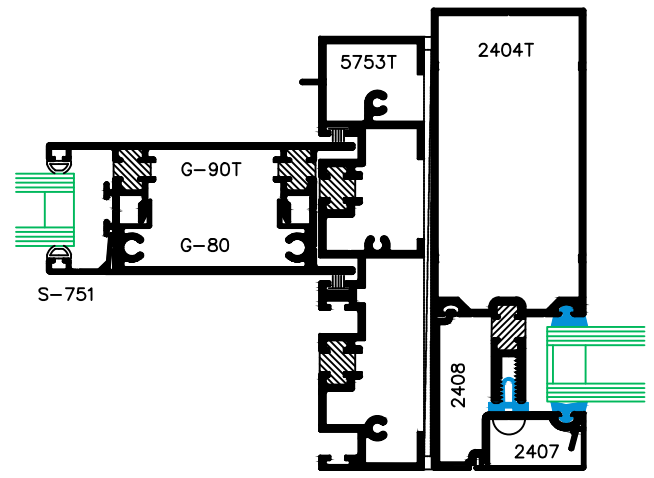

SLIDING DOORS

16a

1100T JAMB AT FIXED PANEL



**INTERFACE DETAILS
(SUGGESTED ONLY)**

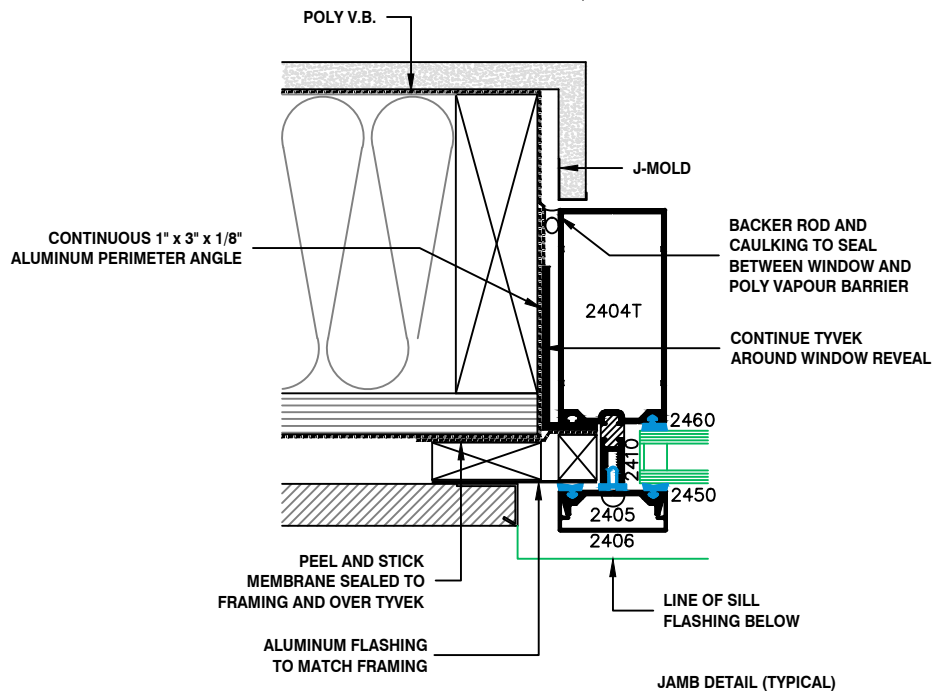
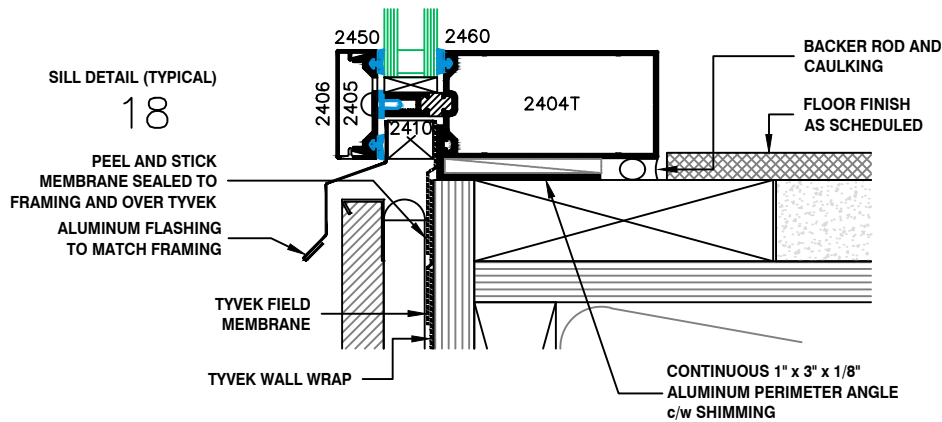
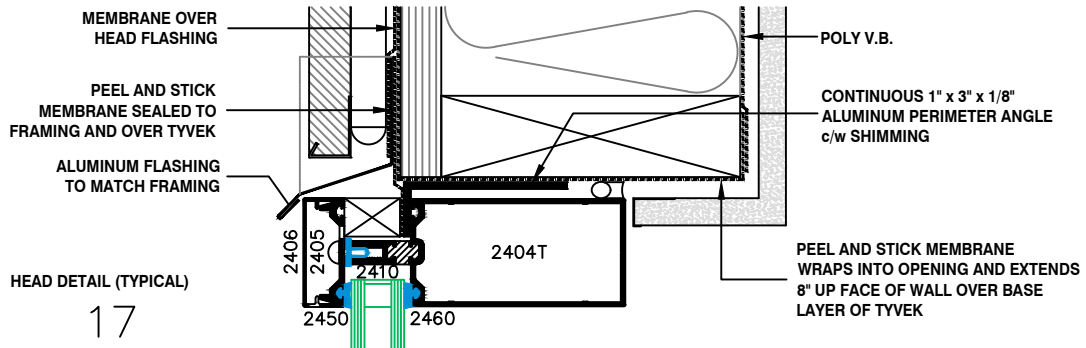



TYPICAL ANCHORING DETAILS

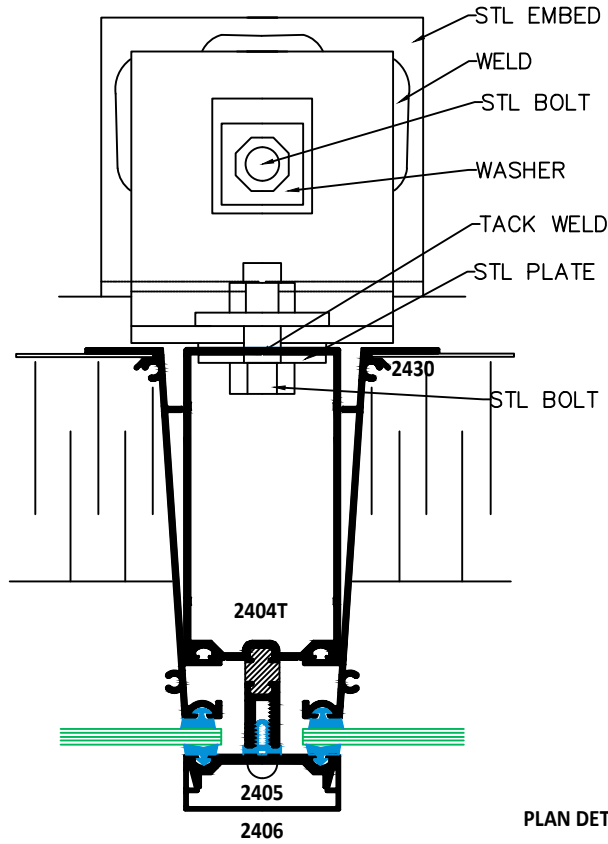

PLAN DETAILS

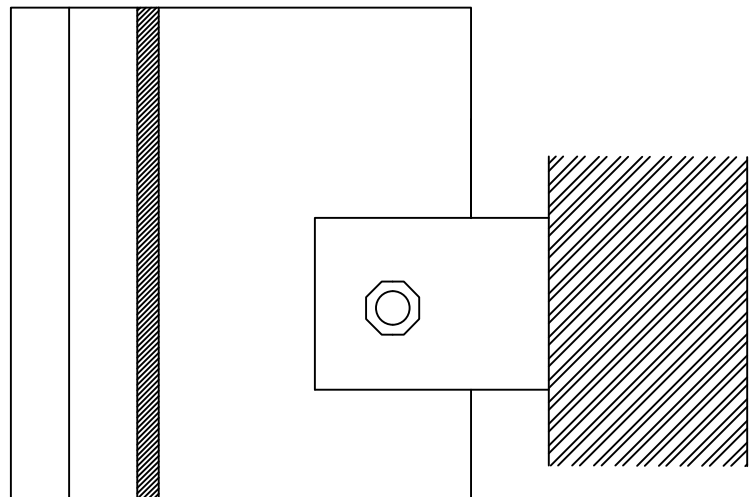
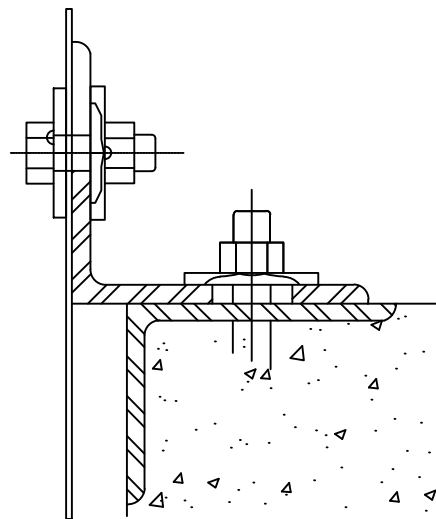
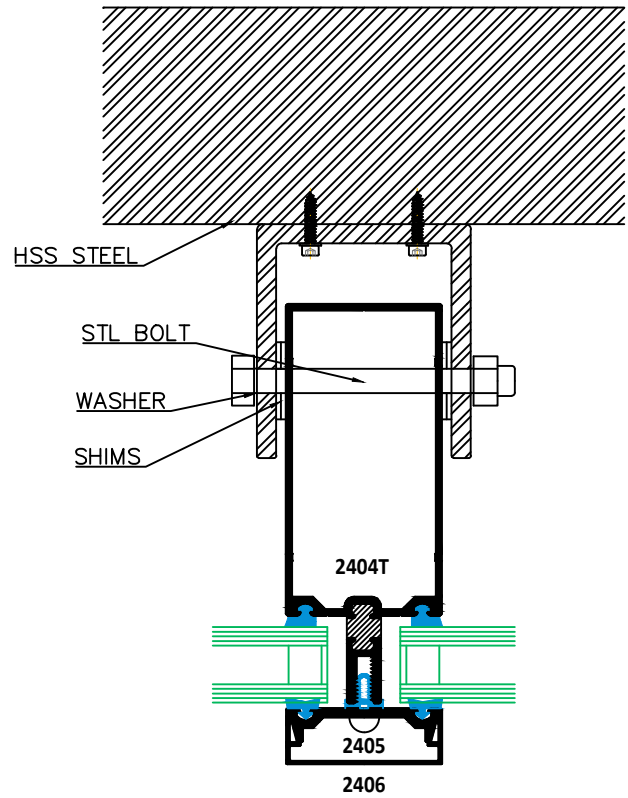

SECTION DETAILS

EXPANSION & SPLICE DETAILS

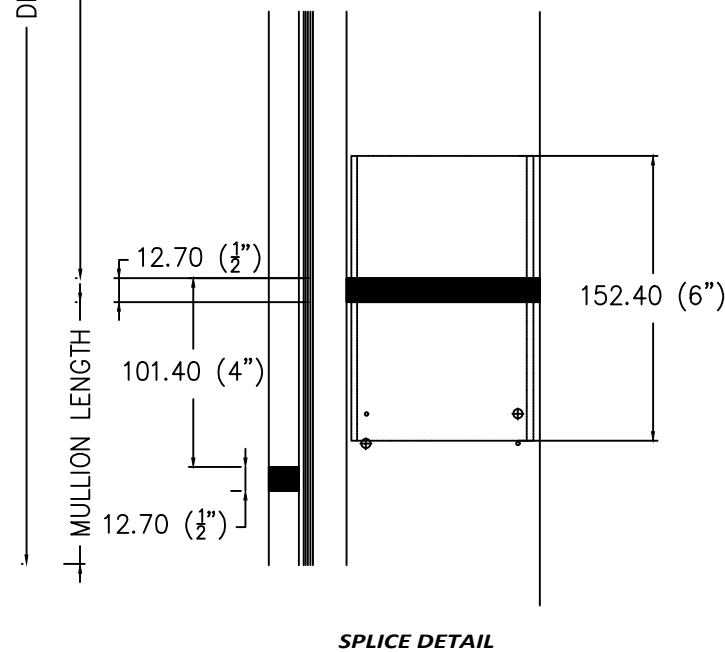
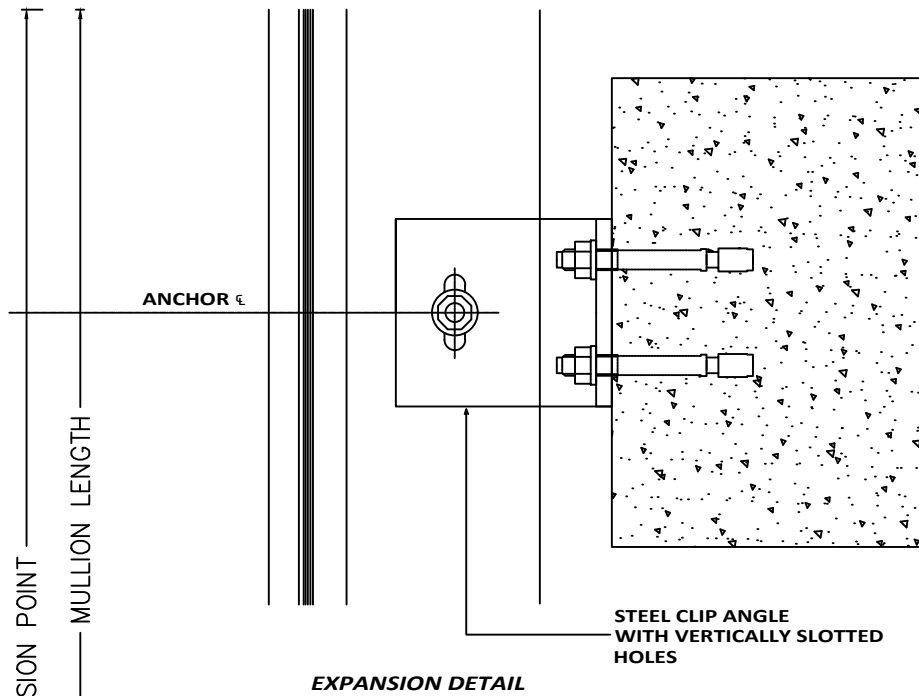

WIND LOAD CHART FOR 2" x 2" T/B MULLION - PART # 2402T

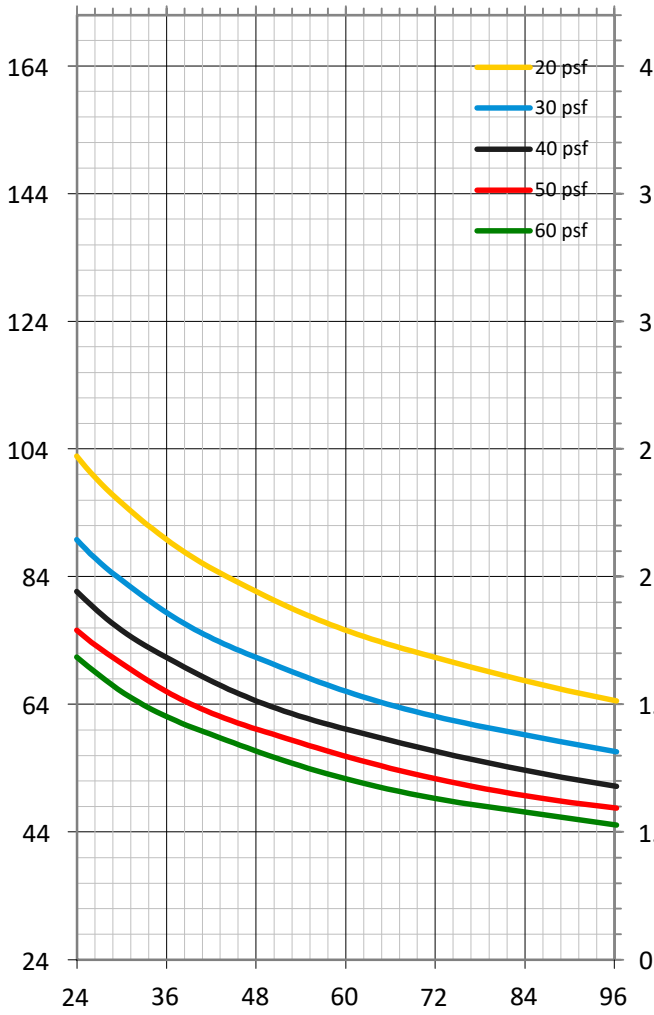
SPAN CHART	MULLION SECTION																				
<p>SPAN CHART IS FOR ESTIMATION ONLY. DO NOT UTILIZE FOR DETAILED DESIGN. CHART IS BASED ON DEFLECTION ANALYSIS ONLY</p>																					
<p style="text-align: center;">Mullion Centres (Tributary width) In Meters</p> <p style="text-align: center;">0.6 0.9 1.2 1.5 1.8 2.1 2.4</p> <div style="display: flex; justify-content: space-between;"> <div style="width: 45%;"> <p style="transform: rotate(-90deg); transform-origin: left top;">Mullion Height in Inches</p> <p style="transform: rotate(-90deg); transform-origin: left top;">Mullion Height in Meters</p> </div> <div style="width: 50%; text-align: right;"> <p>164 4.17</p> <p>144 3.66</p> <p>124 3.15</p> <p>104 2.64</p> <p>84 2.13</p> <p>64 1.63</p> <p>44 1.12</p> <p>24 0.61</p> </div> </div>  <p style="text-align: center;">Mullion Centres (Tributary width) In Inches</p> <p style="text-align: center;">24 36 48 60 72 84 96</p>	<table border="1" style="width: 100%; border-collapse: collapse;"> <thead> <tr style="background-color: #cccccc;"> <th colspan="2" style="text-align: center;">SYSTEM PROPERTIES</th> </tr> </thead> <tbody> <tr> <th colspan="2" style="text-align: center;">Moment of Inertia, Section Modulus & Area</th> </tr> <tr> <td style="width: 50%;">Moment of Inertia, Ixx</td> <td>Ixx = 0.83 in4</td> </tr> <tr> <td>Section Modulus, Sxx</td> <td>Sxx = 0.38 in3</td> </tr> <tr> <td>Total Area</td> <td>A = 0.92 in2</td> </tr> <tr> <th colspan="2" style="text-align: center;">Modulus of Elasticity</th> </tr> <tr> <td>Aluminum</td> <td>10,000,000 PSI</td> </tr> <tr> <td>Steel</td> <td>29,000,000 PSI</td> </tr> <tr> <th colspan="2" style="text-align: center;">GENERAL NOTES</th> </tr> <tr> <td colspan="2"> <ol style="list-style-type: none"> 1. Deflection Limit: L/175 up to 13.5ft, L/240 + 0.25" over 13.5ft 2. Assume horizontal members provide lateral support 3. Steel moment of inertia converted to polyester, vinyl or aluminum equivalent 4. CANADIAN PROJECTS: Use SLS wind loads or modify the specified wind load by 0.75 before utilizing this chart. i.e. if project specifications require pnet = 40 psf, utilize 30 psf on this chart (0.75 x 40 = 30). (Based on NBCC 2020). </td> </tr> </tbody> </table>	SYSTEM PROPERTIES		Moment of Inertia, Section Modulus & Area		Moment of Inertia, Ixx	Ixx = 0.83 in4	Section Modulus, Sxx	Sxx = 0.38 in3	Total Area	A = 0.92 in2	Modulus of Elasticity		Aluminum	10,000,000 PSI	Steel	29,000,000 PSI	GENERAL NOTES		<ol style="list-style-type: none"> 1. Deflection Limit: L/175 up to 13.5ft, L/240 + 0.25" over 13.5ft 2. Assume horizontal members provide lateral support 3. Steel moment of inertia converted to polyester, vinyl or aluminum equivalent 4. CANADIAN PROJECTS: Use SLS wind loads or modify the specified wind load by 0.75 before utilizing this chart. i.e. if project specifications require pnet = 40 psf, utilize 30 psf on this chart (0.75 x 40 = 30). (Based on NBCC 2020). 	
SYSTEM PROPERTIES																					
Moment of Inertia, Section Modulus & Area																					
Moment of Inertia, Ixx	Ixx = 0.83 in4																				
Section Modulus, Sxx	Sxx = 0.38 in3																				
Total Area	A = 0.92 in2																				
Modulus of Elasticity																					
Aluminum	10,000,000 PSI																				
Steel	29,000,000 PSI																				
GENERAL NOTES																					
<ol style="list-style-type: none"> 1. Deflection Limit: L/175 up to 13.5ft, L/240 + 0.25" over 13.5ft 2. Assume horizontal members provide lateral support 3. Steel moment of inertia converted to polyester, vinyl or aluminum equivalent 4. CANADIAN PROJECTS: Use SLS wind loads or modify the specified wind load by 0.75 before utilizing this chart. i.e. if project specifications require pnet = 40 psf, utilize 30 psf on this chart (0.75 x 40 = 30). (Based on NBCC 2020). 																					

DEAD LOAD CHART FOR 2" x 2" T/B MULLION - PART # 2402T

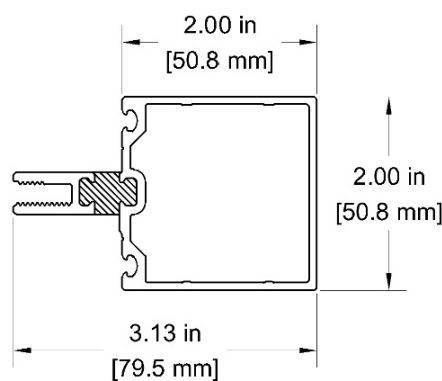
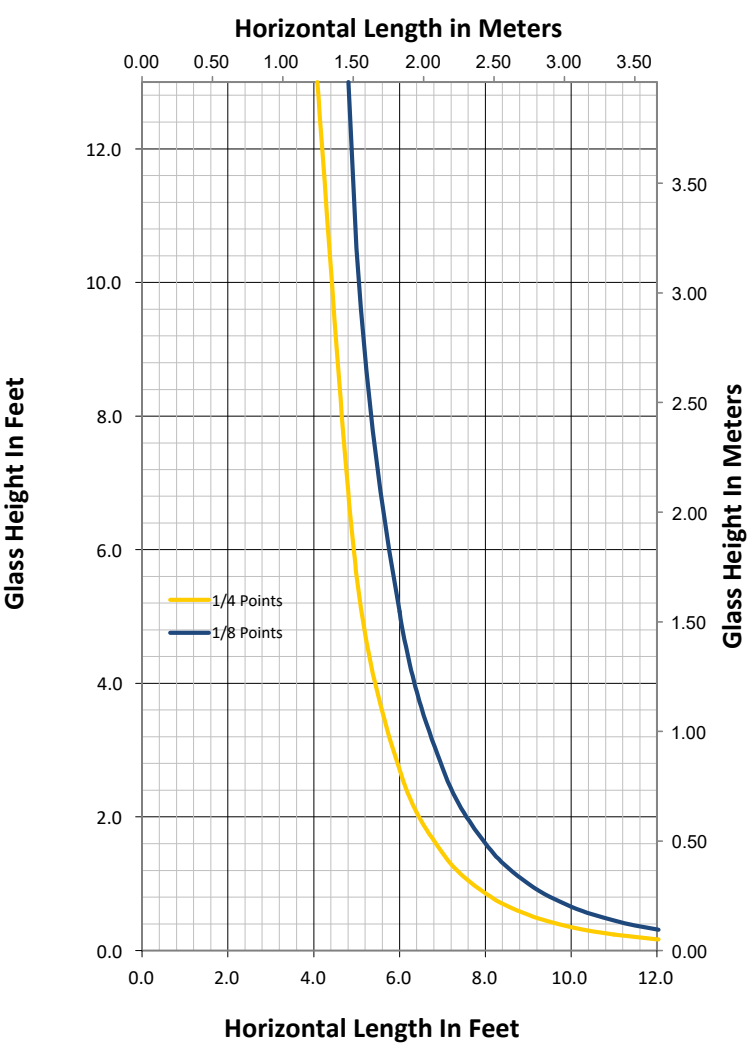
SPAN CHART	MULLION SECTION																				
<p>SPAN CHART IS FOR ESTIMATION ONLY. DO NOT UTILIZE FOR DETAILED DESIGN. CHART IS BASED ON DEFLECTION ANALYSIS ONLY</p>																					
 <p>Horizontal Length in Meters</p> <p>Glass Height In Feet</p> <p>Glass Height In Meters</p> <p>Horizontal Length In Feet</p> <p>— 1/4 Points — 1/8 Points</p>	<table border="1" style="width: 100%; border-collapse: collapse;"> <thead> <tr style="background-color: #cccccc;"> <th colspan="2" style="text-align: center;">SYSTEM PROPERTIES</th> </tr> </thead> <tbody> <tr> <th colspan="2" style="text-align: center;">Moment of Inertia, Section Modulus & Area</th> </tr> <tr> <td>Moment of Inertia, I_{yy}</td> <td>I_{yy} = 0.42 in⁴</td> </tr> <tr> <td>Section Modulus, S_{yy}</td> <td>S_{yy} = 0.41 in³</td> </tr> <tr> <td>Total Area</td> <td>A = 0.92 in²</td> </tr> <tr> <th colspan="2" style="text-align: center;">Modulus of Elasticity</th> </tr> <tr> <td>Aluminum</td> <td>10,000,000 PSI</td> </tr> <tr> <td>Steel</td> <td>29,000,000 PSI</td> </tr> <tr> <th colspan="2" style="text-align: center;">GENERAL NOTES</th> </tr> <tr> <td colspan="2"> <ol style="list-style-type: none"> 1. Deflection Limit: 0.125" (3.2mm). 2. Charts are calculated assuming a 1" overall sealed unit (6mm/13mm spacer/6mm) 3. Calculations are based on the position of the setting blocks being placed at 1/4 or 1/8 points. </td> </tr> </tbody> </table>	SYSTEM PROPERTIES		Moment of Inertia, Section Modulus & Area		Moment of Inertia, I _{yy}	I _{yy} = 0.42 in ⁴	Section Modulus, S _{yy}	S _{yy} = 0.41 in ³	Total Area	A = 0.92 in ²	Modulus of Elasticity		Aluminum	10,000,000 PSI	Steel	29,000,000 PSI	GENERAL NOTES		<ol style="list-style-type: none"> 1. Deflection Limit: 0.125" (3.2mm). 2. Charts are calculated assuming a 1" overall sealed unit (6mm/13mm spacer/6mm) 3. Calculations are based on the position of the setting blocks being placed at 1/4 or 1/8 points. 	
SYSTEM PROPERTIES																					
Moment of Inertia, Section Modulus & Area																					
Moment of Inertia, I _{yy}	I _{yy} = 0.42 in ⁴																				
Section Modulus, S _{yy}	S _{yy} = 0.41 in ³																				
Total Area	A = 0.92 in ²																				
Modulus of Elasticity																					
Aluminum	10,000,000 PSI																				
Steel	29,000,000 PSI																				
GENERAL NOTES																					
<ol style="list-style-type: none"> 1. Deflection Limit: 0.125" (3.2mm). 2. Charts are calculated assuming a 1" overall sealed unit (6mm/13mm spacer/6mm) 3. Calculations are based on the position of the setting blocks being placed at 1/4 or 1/8 points. 																					

WIND LOAD CHART FOR 2" x 2 3/4" T/B MULLION - PART # 2427T

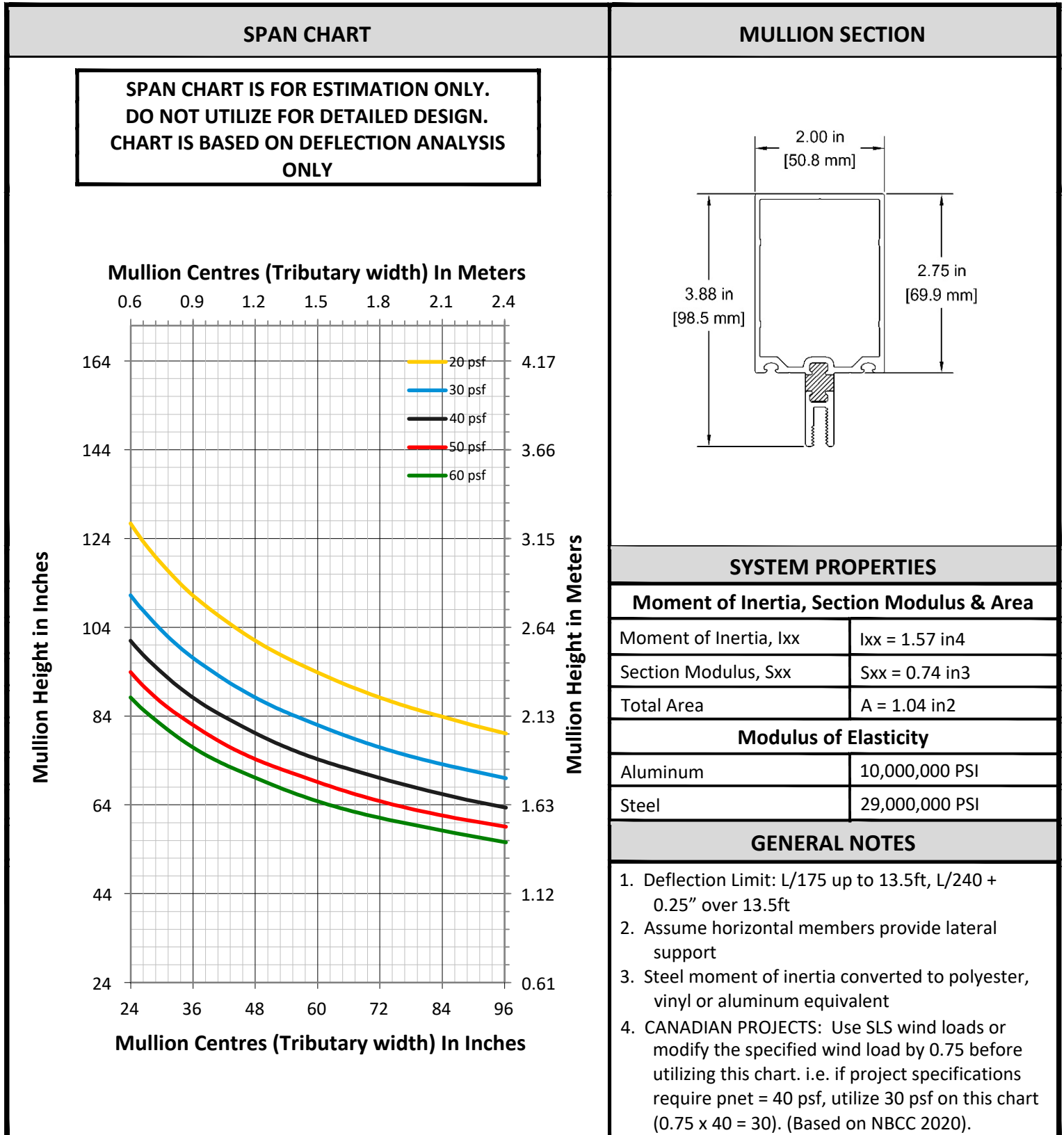

DEAD LOAD CHART FOR 2" x 2 3/4" T/B MULLION - PART # 2427T

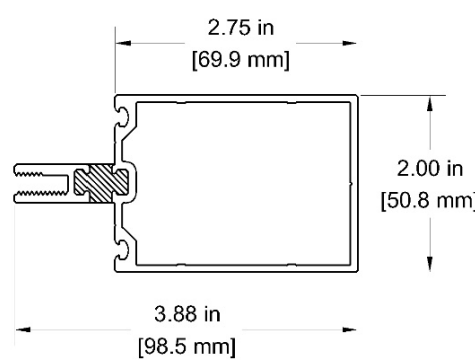
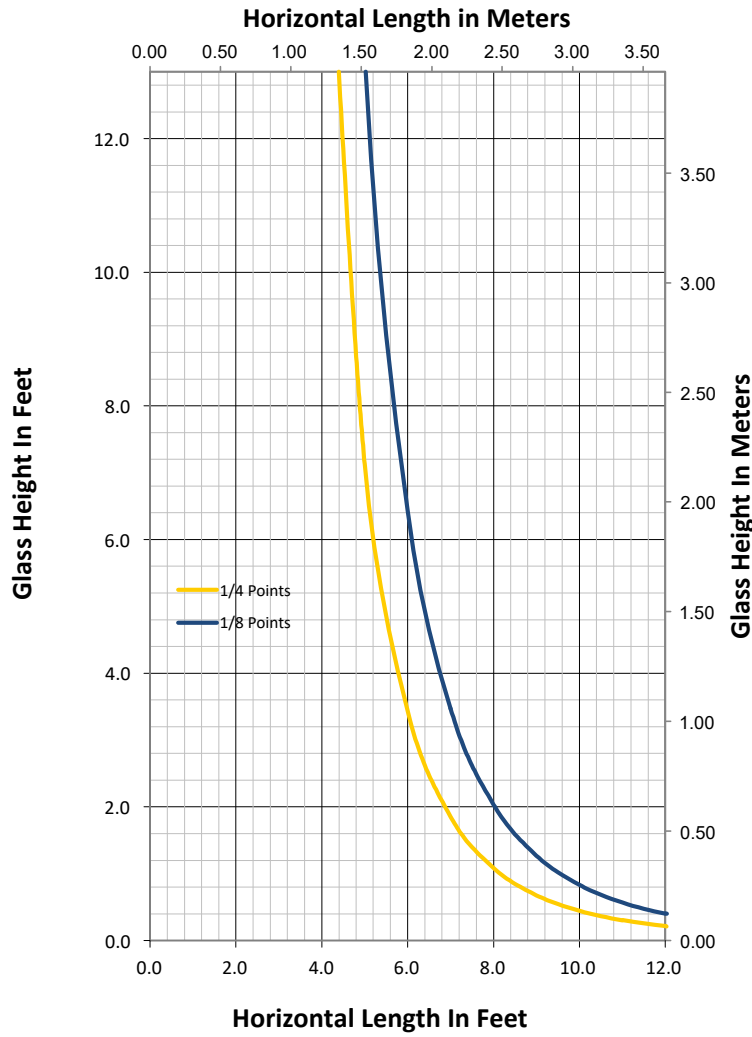
SPAN CHART	MULLION SECTION																				
<p>SPAN CHART IS FOR ESTIMATION ONLY. DO NOT UTILIZE FOR DETAILED DESIGN. CHART IS BASED ON DEFLECTION ANALYSIS ONLY</p>																					
	<table border="1" style="width: 100%; border-collapse: collapse;"> <thead> <tr style="background-color: #cccccc;"> <th colspan="2" style="text-align: center;">SYSTEM PROPERTIES</th> </tr> </thead> <tbody> <tr> <th colspan="2" style="text-align: center;">Moment of Inertia, Section Modulus & Area</th> </tr> <tr> <td style="text-align: left;">Moment of Inertia, I_{yy}</td> <td>I_{yy} = 0.53 in⁴</td> </tr> <tr> <td style="text-align: left;">Section Modulus, S_{yy}</td> <td>S_{yy} = 0.52 in³</td> </tr> <tr> <td style="text-align: left;">Total Area</td> <td>A = 1.04 in²</td> </tr> <tr> <th colspan="2" style="text-align: center;">Modulus of Elasticity</th> </tr> <tr> <td style="text-align: left;">Aluminum</td> <td>10,000,000 PSI</td> </tr> <tr> <td style="text-align: left;">Steel</td> <td>29,000,000 PSI</td> </tr> <tr> <th colspan="2" style="text-align: center;">GENERAL NOTES</th> </tr> <tr> <td colspan="2"> <ol style="list-style-type: none"> 1. Deflection Limit: 0.125" (3.2mm). 2. Charts are calculated assuming a 1" overall sealed unit (6mm/13mm spacer/6mm) 3. Calculations are based on the position of the setting blocks being placed at 1/4 or 1/8 points. </td> </tr> </tbody> </table>	SYSTEM PROPERTIES		Moment of Inertia, Section Modulus & Area		Moment of Inertia, I _{yy}	I _{yy} = 0.53 in ⁴	Section Modulus, S _{yy}	S _{yy} = 0.52 in ³	Total Area	A = 1.04 in ²	Modulus of Elasticity		Aluminum	10,000,000 PSI	Steel	29,000,000 PSI	GENERAL NOTES		<ol style="list-style-type: none"> 1. Deflection Limit: 0.125" (3.2mm). 2. Charts are calculated assuming a 1" overall sealed unit (6mm/13mm spacer/6mm) 3. Calculations are based on the position of the setting blocks being placed at 1/4 or 1/8 points. 	
SYSTEM PROPERTIES																					
Moment of Inertia, Section Modulus & Area																					
Moment of Inertia, I _{yy}	I _{yy} = 0.53 in ⁴																				
Section Modulus, S _{yy}	S _{yy} = 0.52 in ³																				
Total Area	A = 1.04 in ²																				
Modulus of Elasticity																					
Aluminum	10,000,000 PSI																				
Steel	29,000,000 PSI																				
GENERAL NOTES																					
<ol style="list-style-type: none"> 1. Deflection Limit: 0.125" (3.2mm). 2. Charts are calculated assuming a 1" overall sealed unit (6mm/13mm spacer/6mm) 3. Calculations are based on the position of the setting blocks being placed at 1/4 or 1/8 points. 																					

WIND LOAD CHART FOR 2" x 4" T/B MULLION - PART # 2404T

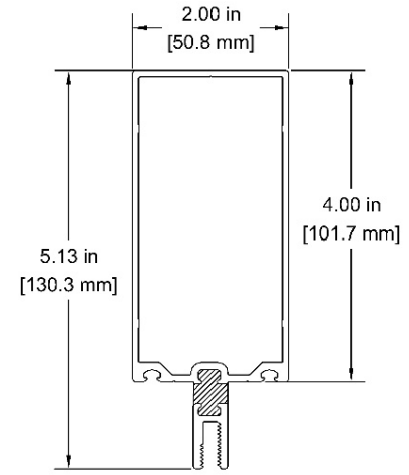
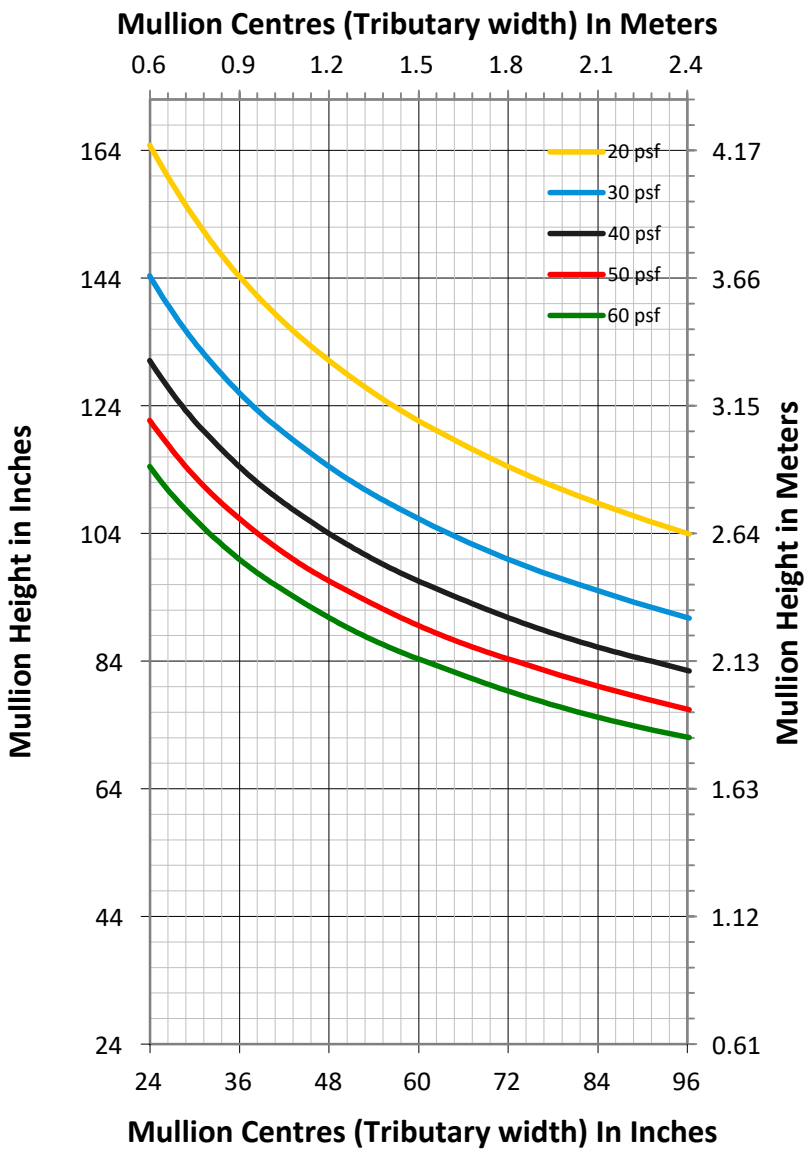
SPAN CHART	MULLION SECTION																				
<p>SPAN CHART IS FOR ESTIMATION ONLY. DO NOT UTILIZE FOR DETAILED DESIGN. CHART IS BASED ON DEFLECTION ANALYSIS ONLY</p>																					
<p style="text-align: center;">Mullion Centres (Tributary width) In Meters</p> <p style="text-align: center;">0.6 0.9 1.2 1.5 1.8 2.1 2.4</p>  <p style="text-align: center;">Mullion Centres (Tributary width) In Inches</p> <p style="text-align: center;">24 36 48 60 72 84 96</p>	<table border="1" style="width: 100%; border-collapse: collapse;"> <thead> <tr style="background-color: #cccccc;"> <th colspan="2" style="text-align: center;">SYSTEM PROPERTIES</th> </tr> </thead> <tbody> <tr> <th colspan="2" style="text-align: center;">Moment of Inertia, Section Modulus & Area</th> </tr> <tr> <td style="width: 50%;">Moment of Inertia, I_{xx}</td> <td>I_{xx} = 3.42 in⁴</td> </tr> <tr> <td>Section Modulus, S_{xx}</td> <td>S_{xx} = 1.08 in³</td> </tr> <tr> <td>Total Area</td> <td>A = 1.24 in²</td> </tr> <tr> <th colspan="2" style="text-align: center;">Modulus of Elasticity</th> </tr> <tr> <td>Aluminum</td> <td>10,000,000 PSI</td> </tr> <tr> <td>Steel</td> <td>29,000,000 PSI</td> </tr> <tr style="background-color: #cccccc;"> <th colspan="2" style="text-align: center;">GENERAL NOTES</th> </tr> <tr> <td colspan="2"> <ol style="list-style-type: none"> 1. Deflection Limit: L/175 up to 13.5ft, L/240 + 0.25" over 13.5ft 2. Assume horizontal members provide lateral support 3. Steel moment of inertia converted to polyester, vinyl or aluminum equivalent 4. CANADIAN PROJECTS: Use SLS wind loads or modify the specified wind load by 0.75 before utilizing this chart. i.e. if project specifications require pnet = 40 psf, utilize 30 psf on this chart (0.75 x 40 = 30). (Based on NBCC 2020). </td> </tr> </tbody> </table>	SYSTEM PROPERTIES		Moment of Inertia, Section Modulus & Area		Moment of Inertia, I _{xx}	I _{xx} = 3.42 in ⁴	Section Modulus, S _{xx}	S _{xx} = 1.08 in ³	Total Area	A = 1.24 in ²	Modulus of Elasticity		Aluminum	10,000,000 PSI	Steel	29,000,000 PSI	GENERAL NOTES		<ol style="list-style-type: none"> 1. Deflection Limit: L/175 up to 13.5ft, L/240 + 0.25" over 13.5ft 2. Assume horizontal members provide lateral support 3. Steel moment of inertia converted to polyester, vinyl or aluminum equivalent 4. CANADIAN PROJECTS: Use SLS wind loads or modify the specified wind load by 0.75 before utilizing this chart. i.e. if project specifications require pnet = 40 psf, utilize 30 psf on this chart (0.75 x 40 = 30). (Based on NBCC 2020). 	
SYSTEM PROPERTIES																					
Moment of Inertia, Section Modulus & Area																					
Moment of Inertia, I _{xx}	I _{xx} = 3.42 in ⁴																				
Section Modulus, S _{xx}	S _{xx} = 1.08 in ³																				
Total Area	A = 1.24 in ²																				
Modulus of Elasticity																					
Aluminum	10,000,000 PSI																				
Steel	29,000,000 PSI																				
GENERAL NOTES																					
<ol style="list-style-type: none"> 1. Deflection Limit: L/175 up to 13.5ft, L/240 + 0.25" over 13.5ft 2. Assume horizontal members provide lateral support 3. Steel moment of inertia converted to polyester, vinyl or aluminum equivalent 4. CANADIAN PROJECTS: Use SLS wind loads or modify the specified wind load by 0.75 before utilizing this chart. i.e. if project specifications require pnet = 40 psf, utilize 30 psf on this chart (0.75 x 40 = 30). (Based on NBCC 2020). 																					

STEEL LOADED WIND LOAD CHART FOR 2" x 4" T/B MULLION - PART # 2404T

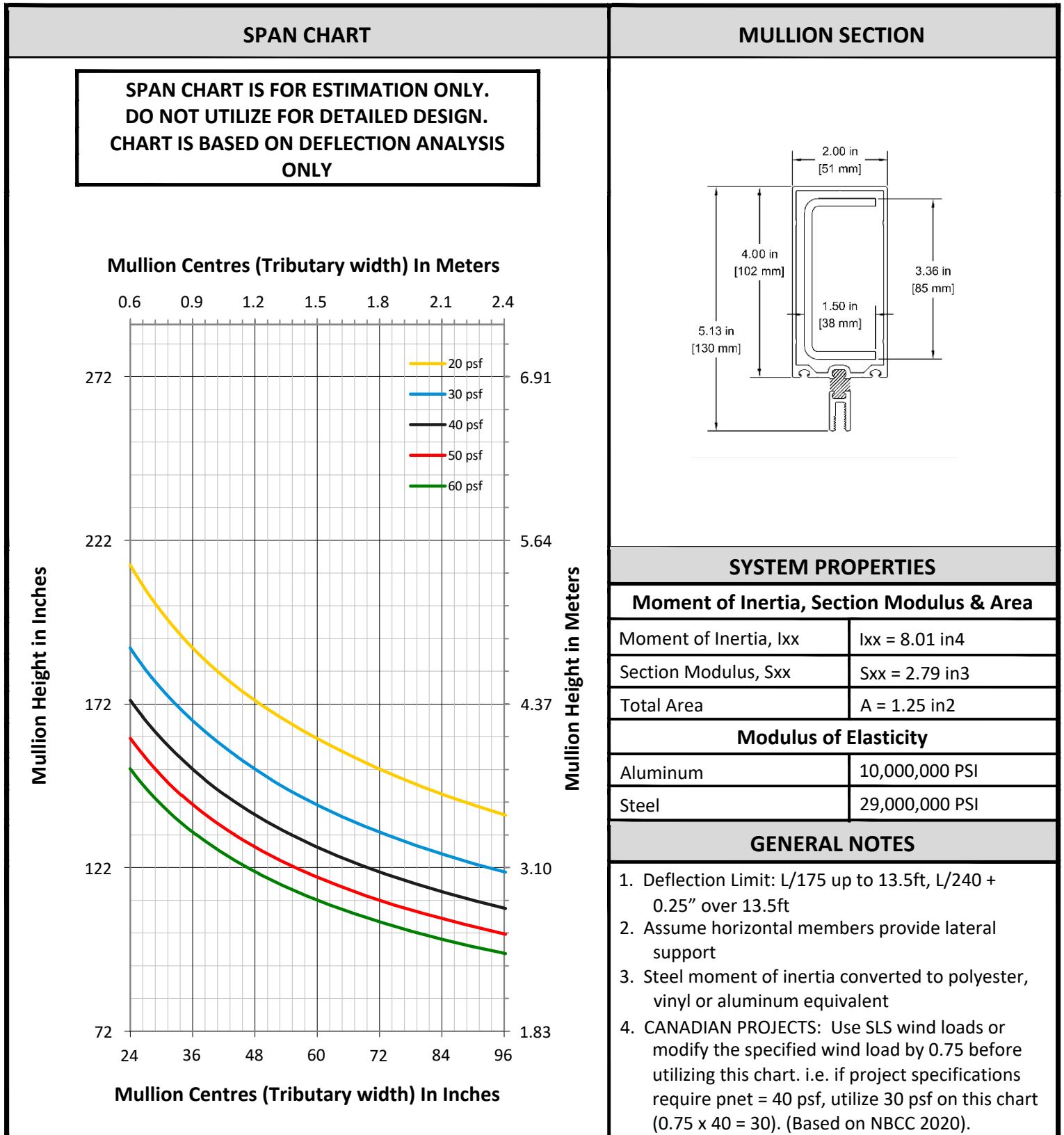

DEAD LOAD CHART FOR 2" x 4" T/B MULLION - PART # 2404T

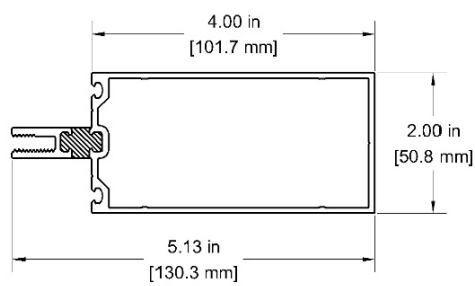
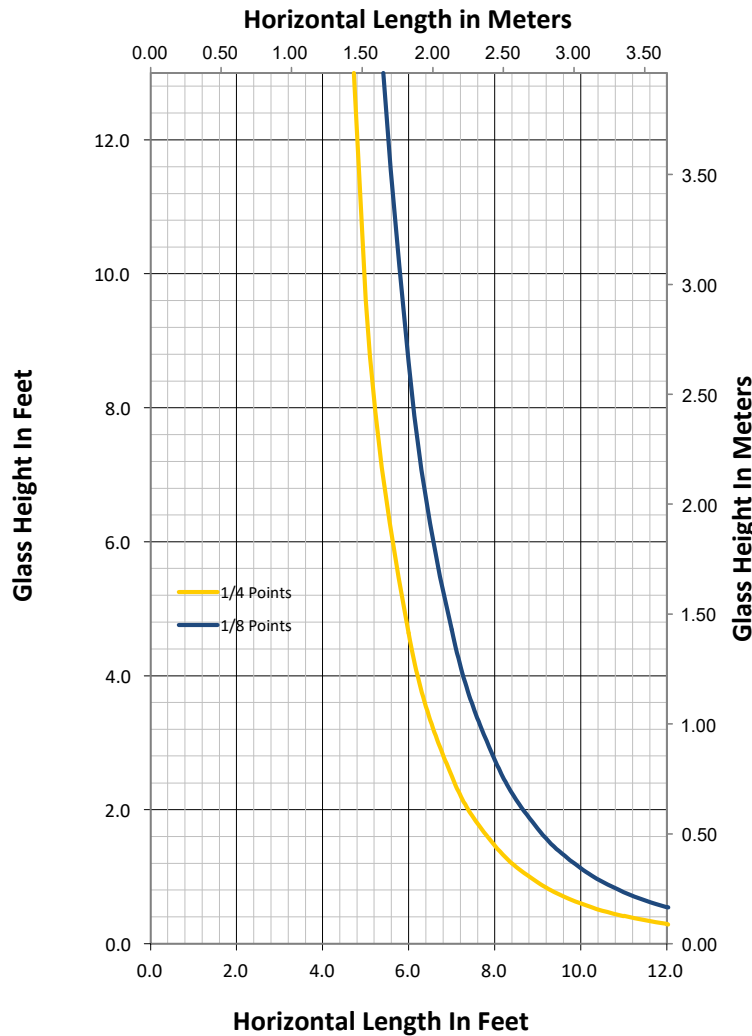
SPAN CHART	MULLION SECTION																				
<p>SPAN CHART IS FOR ESTIMATION ONLY. DO NOT UTILIZE FOR DETAILED DESIGN. CHART IS BASED ON DEFLECTION ANALYSIS ONLY</p>																					
 <p>Horizontal Length in Meters</p> <p>Glass Height In Feet</p> <p>Glass Height In Meters</p> <p>Horizontal Length In Feet</p> <p>— 1/4 Points — 1/8 Points</p>	<table border="1" style="width: 100%; border-collapse: collapse;"> <thead> <tr style="background-color: #cccccc;"> <th colspan="2" style="text-align: center;">SYSTEM PROPERTIES</th> </tr> </thead> <tbody> <tr style="background-color: #cccccc;"> <th colspan="2" style="text-align: center;">Moment of Inertia, Section Modulus & Area</th> </tr> <tr> <td style="width: 50%;">Moment of Inertia, I_{yy}</td> <td>I_{yy} = 0.71 in⁴</td> </tr> <tr> <td>Section Modulus, S_{yy}</td> <td>S_{yy} = 0.71 in³</td> </tr> <tr> <td>Total Area</td> <td>A = 1.24 in²</td> </tr> <tr style="background-color: #cccccc;"> <th colspan="2" style="text-align: center;">Modulus of Elasticity</th> </tr> <tr> <td>Aluminum</td> <td>10,000,000 PSI</td> </tr> <tr> <td>Steel</td> <td>29,000,000 PSI</td> </tr> <tr style="background-color: #cccccc;"> <th colspan="2" style="text-align: center;">GENERAL NOTES</th> </tr> <tr> <td colspan="2"> <ol style="list-style-type: none"> 1. Deflection Limit: 0.125" (3.2mm). 2. Charts are calculated assuming a 1" overall sealed unit (6mm/13mm spacer/6mm) 3. Calculations are based on the position of the setting blocks being placed at 1/4 or 1/8 points. </td> </tr> </tbody> </table>	SYSTEM PROPERTIES		Moment of Inertia, Section Modulus & Area		Moment of Inertia, I _{yy}	I _{yy} = 0.71 in ⁴	Section Modulus, S _{yy}	S _{yy} = 0.71 in ³	Total Area	A = 1.24 in ²	Modulus of Elasticity		Aluminum	10,000,000 PSI	Steel	29,000,000 PSI	GENERAL NOTES		<ol style="list-style-type: none"> 1. Deflection Limit: 0.125" (3.2mm). 2. Charts are calculated assuming a 1" overall sealed unit (6mm/13mm spacer/6mm) 3. Calculations are based on the position of the setting blocks being placed at 1/4 or 1/8 points. 	
SYSTEM PROPERTIES																					
Moment of Inertia, Section Modulus & Area																					
Moment of Inertia, I _{yy}	I _{yy} = 0.71 in ⁴																				
Section Modulus, S _{yy}	S _{yy} = 0.71 in ³																				
Total Area	A = 1.24 in ²																				
Modulus of Elasticity																					
Aluminum	10,000,000 PSI																				
Steel	29,000,000 PSI																				
GENERAL NOTES																					
<ol style="list-style-type: none"> 1. Deflection Limit: 0.125" (3.2mm). 2. Charts are calculated assuming a 1" overall sealed unit (6mm/13mm spacer/6mm) 3. Calculations are based on the position of the setting blocks being placed at 1/4 or 1/8 points. 																					

WIND LOAD CHART FOR 2" x 4" SSG MULLION - PART # 2404SSG

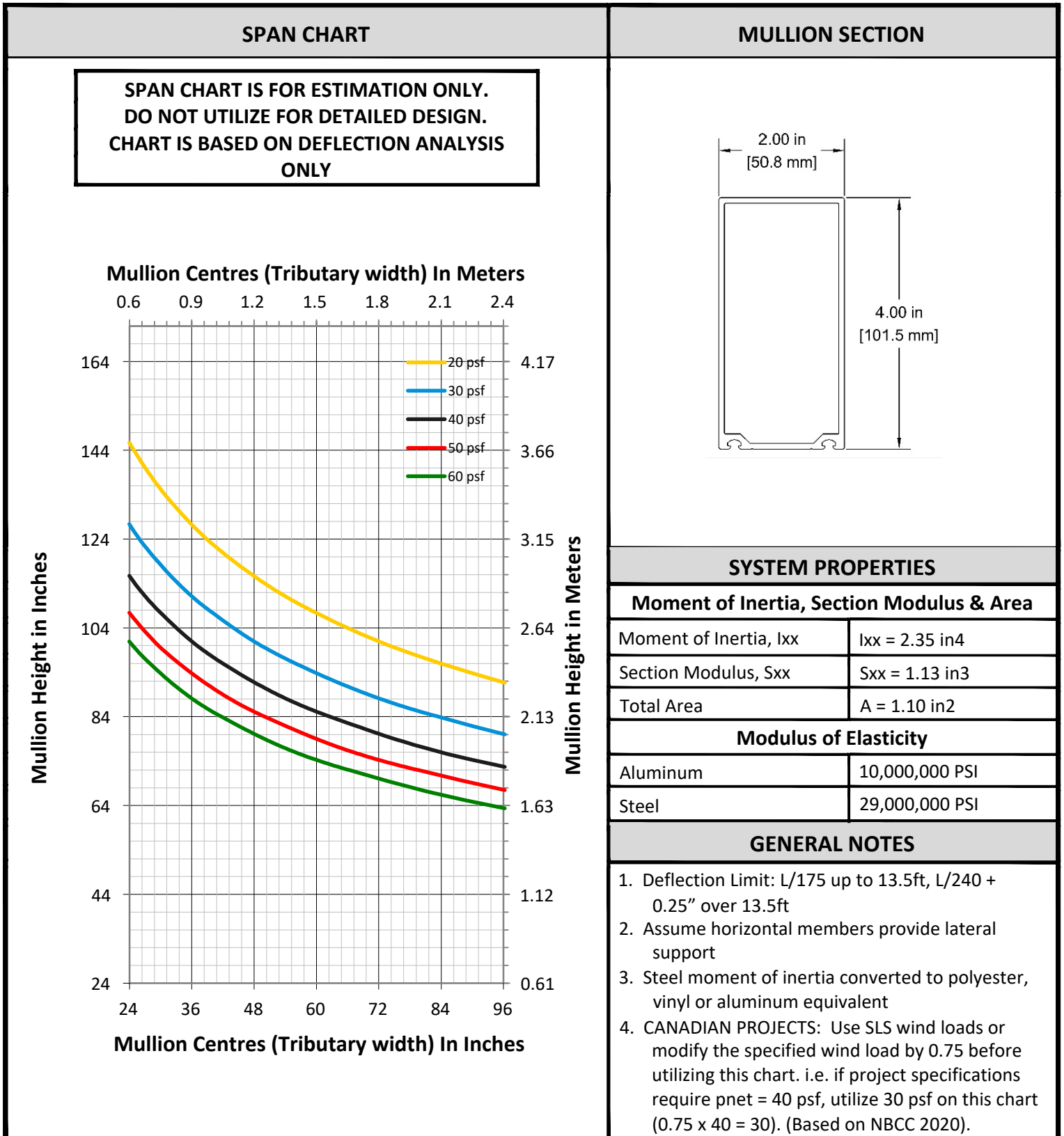

STEEL LOADED WIND LOAD CHART FOR 2" x 4" SSG MULLION - PART # 2404SSG

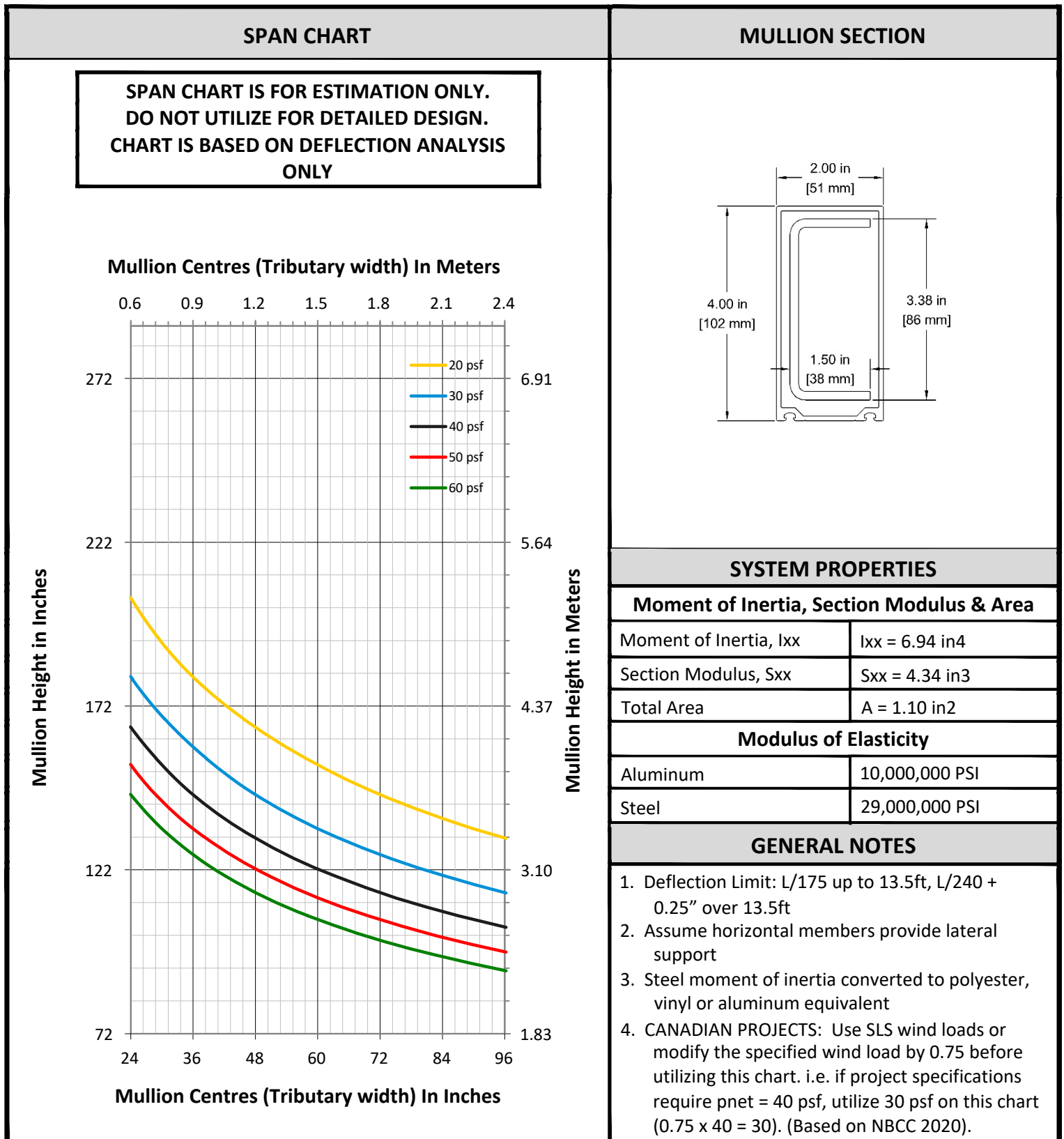

DEAD LOAD CHART FOR 2" x 4" SSG MULLION - PART # 2404SSG

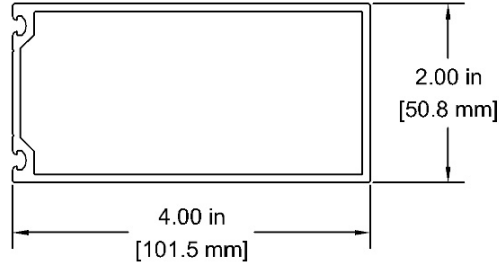
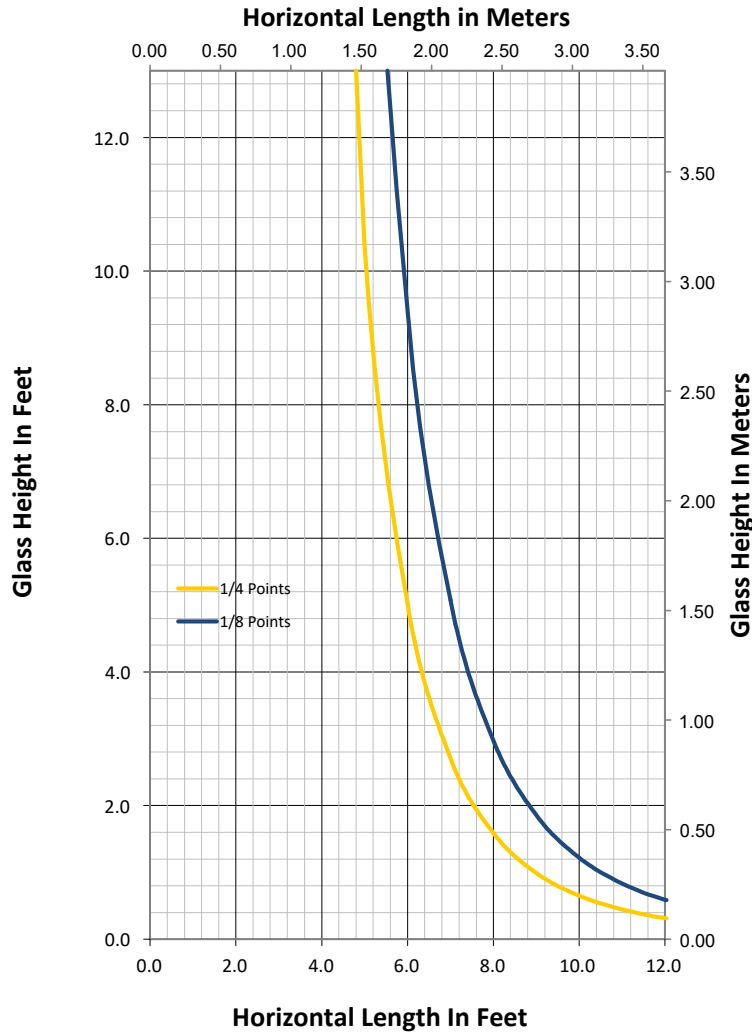
SPAN CHART	MULLION SECTION																				
<p>SPAN CHART IS FOR ESTIMATION ONLY. DO NOT UTILIZE FOR DETAILED DESIGN. CHART IS BASED ON DEFLECTION ANALYSIS ONLY</p>																					
	<table border="1" style="width: 100%; border-collapse: collapse;"> <thead> <tr style="background-color: #cccccc;"> <th colspan="2" style="text-align: center;">SYSTEM PROPERTIES</th> </tr> </thead> <tbody> <tr> <th colspan="2" style="text-align: center;">Moment of Inertia, Section Modulus & Area</th> </tr> <tr> <td style="text-align: left;">Moment of Inertia, I_{yy}</td> <td style="text-align: right;">$I_{yy} = 0.77 \text{ in}^4$</td> </tr> <tr> <td style="text-align: left;">Section Modulus, S_{yy}</td> <td style="text-align: right;">$S_{yy} = 0.77 \text{ in}^3$</td> </tr> <tr> <td style="text-align: left;">Total Area</td> <td style="text-align: right;">$A = 1.10 \text{ in}^2$</td> </tr> <tr> <th colspan="2" style="text-align: center;">Modulus of Elasticity</th> </tr> <tr> <td style="text-align: left;">Aluminum</td> <td style="text-align: right;">10,000,000 PSI</td> </tr> <tr> <td style="text-align: left;">Steel</td> <td style="text-align: right;">29,000,000 PSI</td> </tr> <tr> <th colspan="2" style="text-align: center;">GENERAL NOTES</th> </tr> <tr> <td colspan="2"> <ol style="list-style-type: none"> 1. Deflection Limit: 0.125" (3.2mm). 2. Charts are calculated assuming a 1" overall sealed unit (6mm/13mm spacer/6mm) 3. Calculations are based on the position of the setting blocks being placed at 1/4 or 1/8 points. </td> </tr> </tbody> </table>	SYSTEM PROPERTIES		Moment of Inertia, Section Modulus & Area		Moment of Inertia, I_{yy}	$I_{yy} = 0.77 \text{ in}^4$	Section Modulus, S_{yy}	$S_{yy} = 0.77 \text{ in}^3$	Total Area	$A = 1.10 \text{ in}^2$	Modulus of Elasticity		Aluminum	10,000,000 PSI	Steel	29,000,000 PSI	GENERAL NOTES		<ol style="list-style-type: none"> 1. Deflection Limit: 0.125" (3.2mm). 2. Charts are calculated assuming a 1" overall sealed unit (6mm/13mm spacer/6mm) 3. Calculations are based on the position of the setting blocks being placed at 1/4 or 1/8 points. 	
SYSTEM PROPERTIES																					
Moment of Inertia, Section Modulus & Area																					
Moment of Inertia, I_{yy}	$I_{yy} = 0.77 \text{ in}^4$																				
Section Modulus, S_{yy}	$S_{yy} = 0.77 \text{ in}^3$																				
Total Area	$A = 1.10 \text{ in}^2$																				
Modulus of Elasticity																					
Aluminum	10,000,000 PSI																				
Steel	29,000,000 PSI																				
GENERAL NOTES																					
<ol style="list-style-type: none"> 1. Deflection Limit: 0.125" (3.2mm). 2. Charts are calculated assuming a 1" overall sealed unit (6mm/13mm spacer/6mm) 3. Calculations are based on the position of the setting blocks being placed at 1/4 or 1/8 points. 																					

WIND LOAD CHART FOR 2" x 5 1/4" T/B MULLION - PART # 2425ST

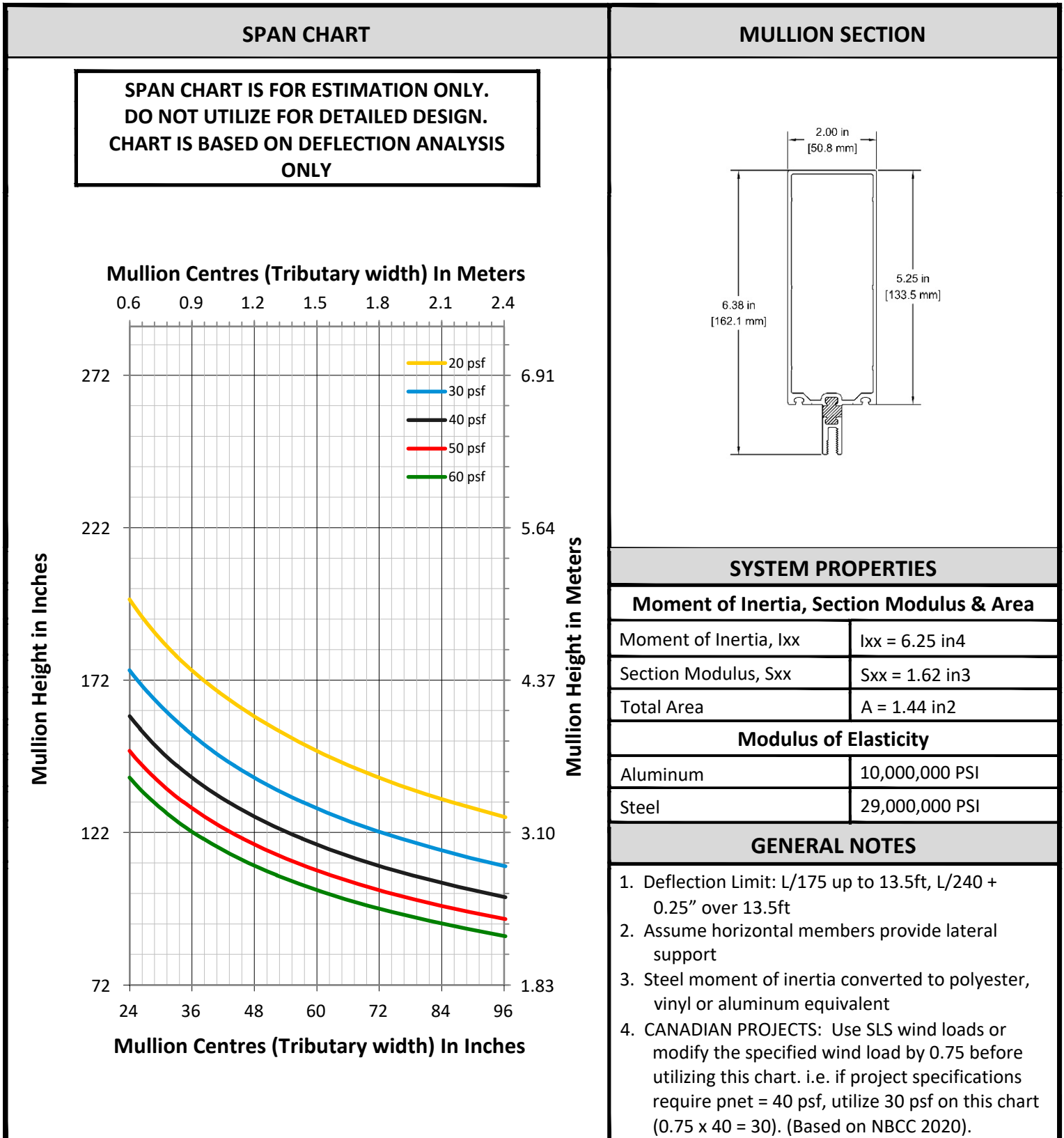

STEEL LOADED WIND LOAD CHART FOR 2" x 5 1/4" T/B MULLION - PART # 2425ST

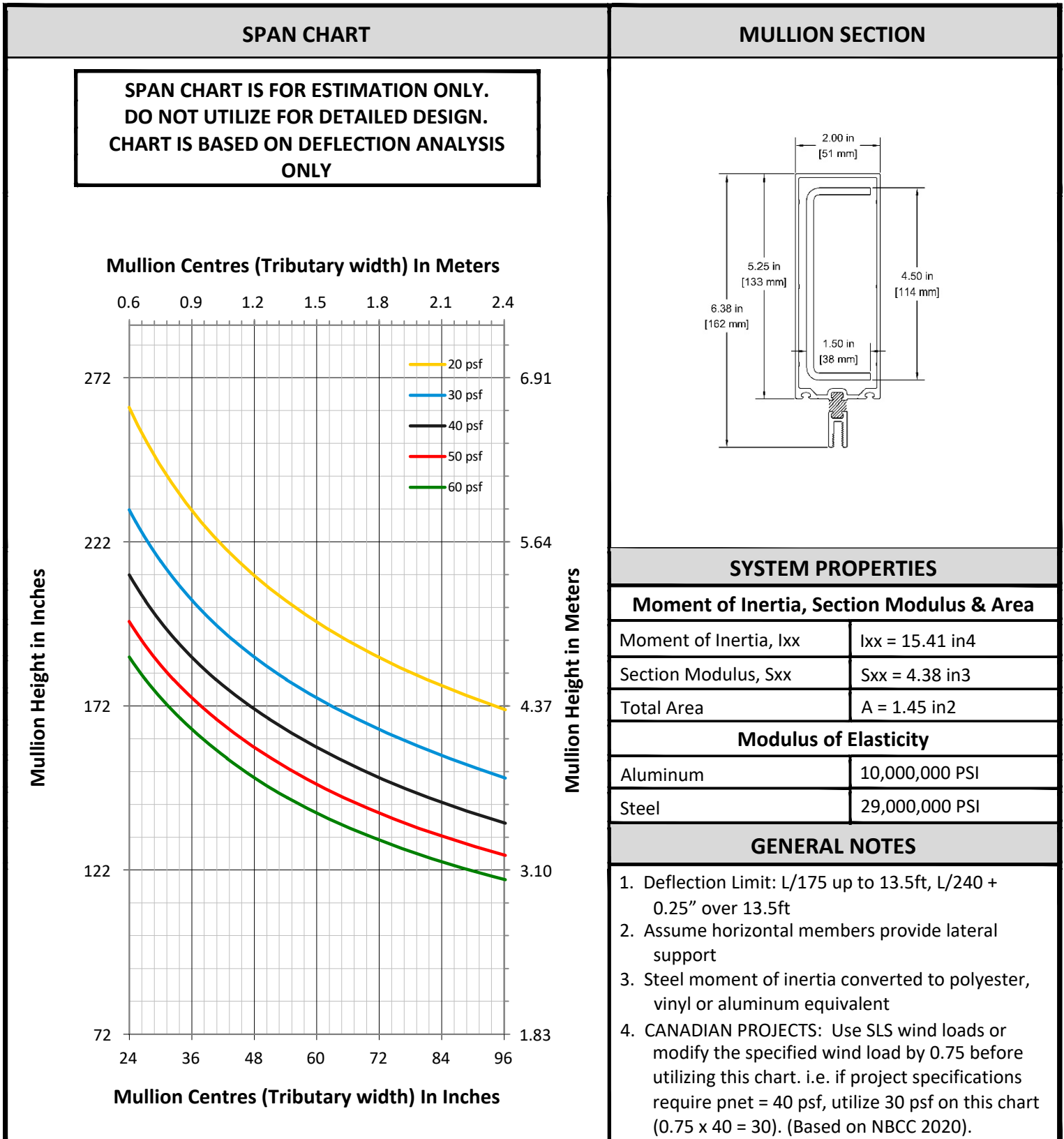

DEAD LOAD CHART FOR 2" x 5 1/4" T/B MULLION - PART # 2425ST

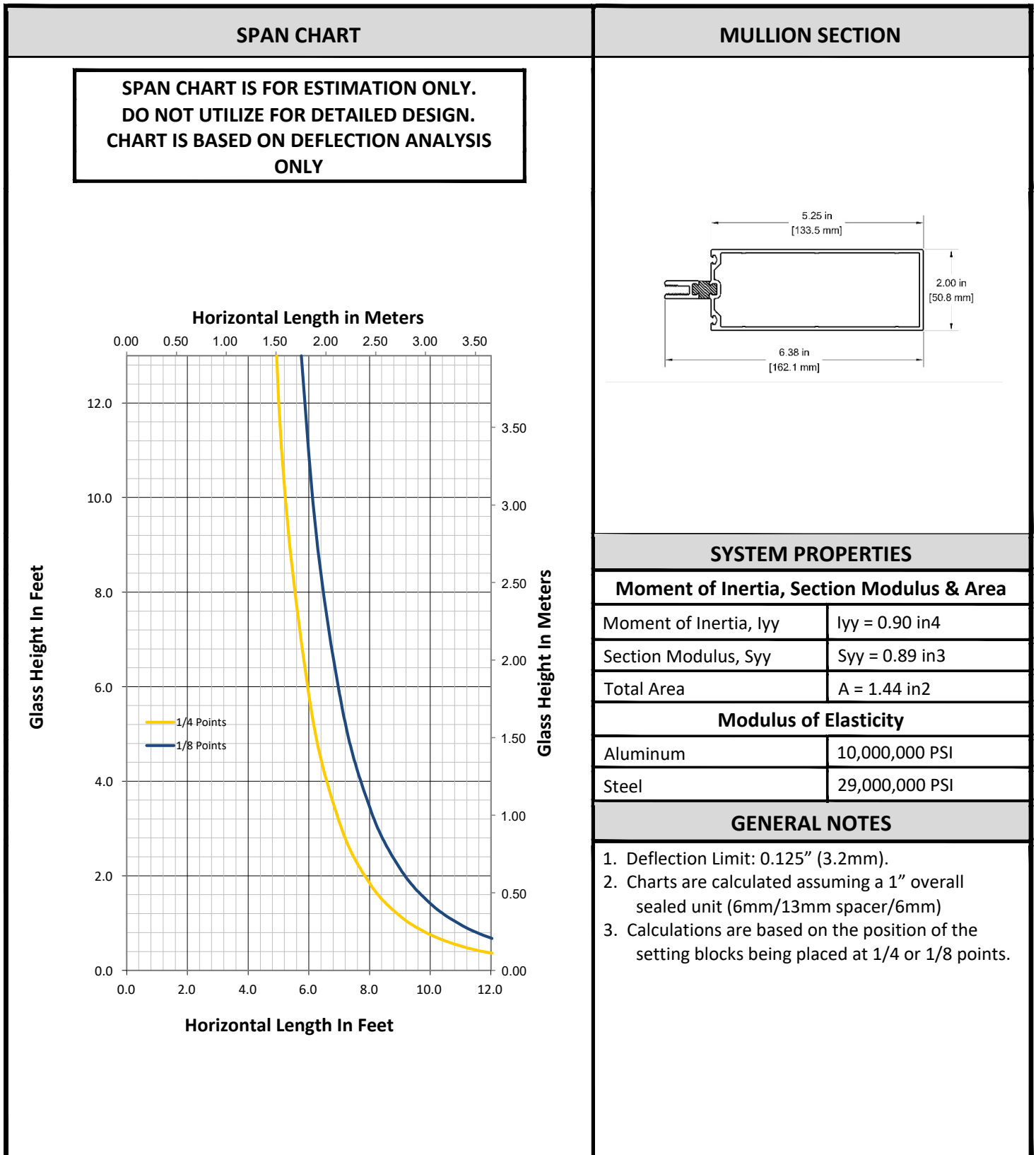

WIND LOAD CHART FOR 2" x 6" T/B MULLION - PART # 2426ST

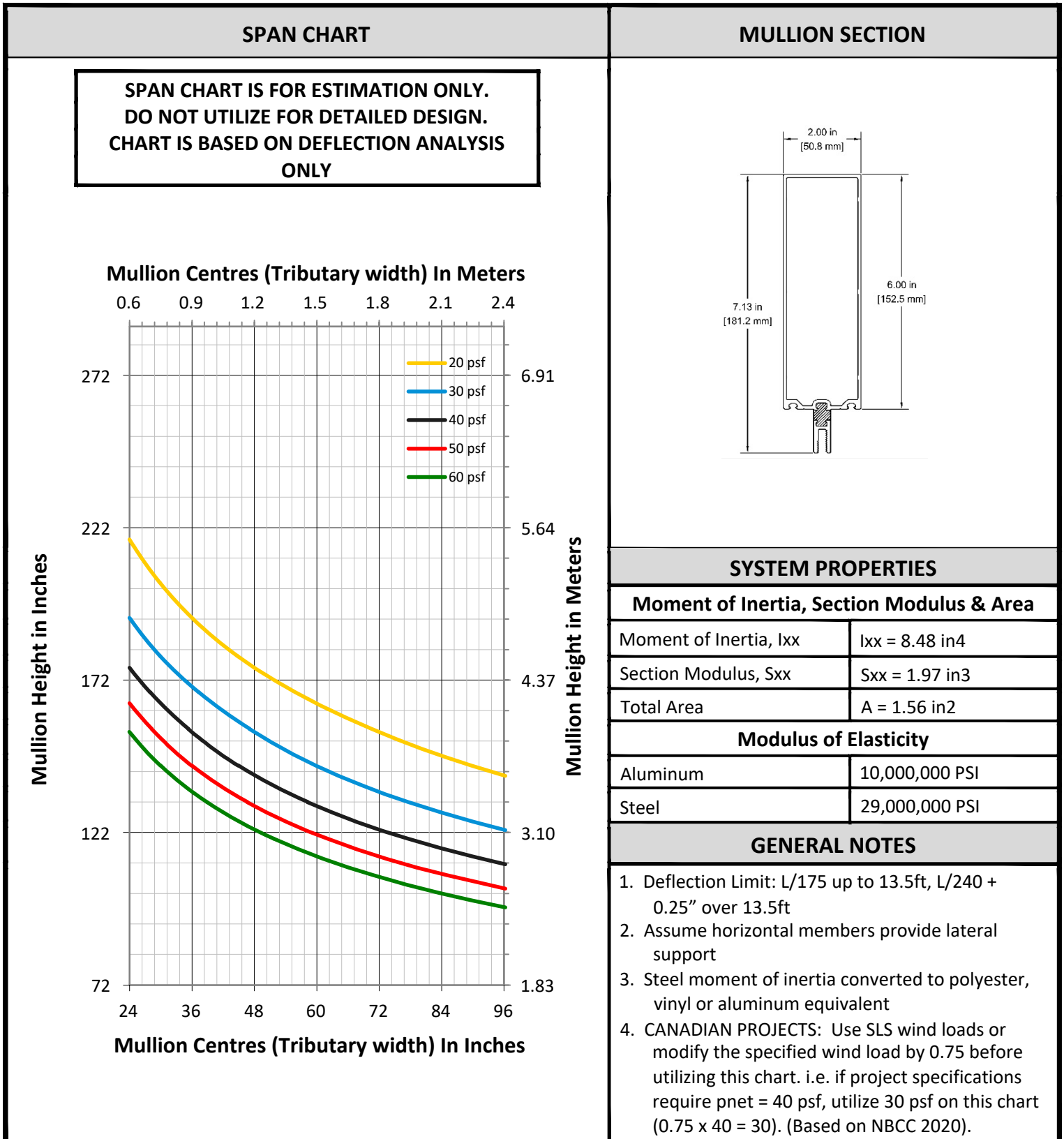

STEEL LOADED WIND LOAD CHART FOR 2" x 6" T/B MULLION - PART # 2426ST

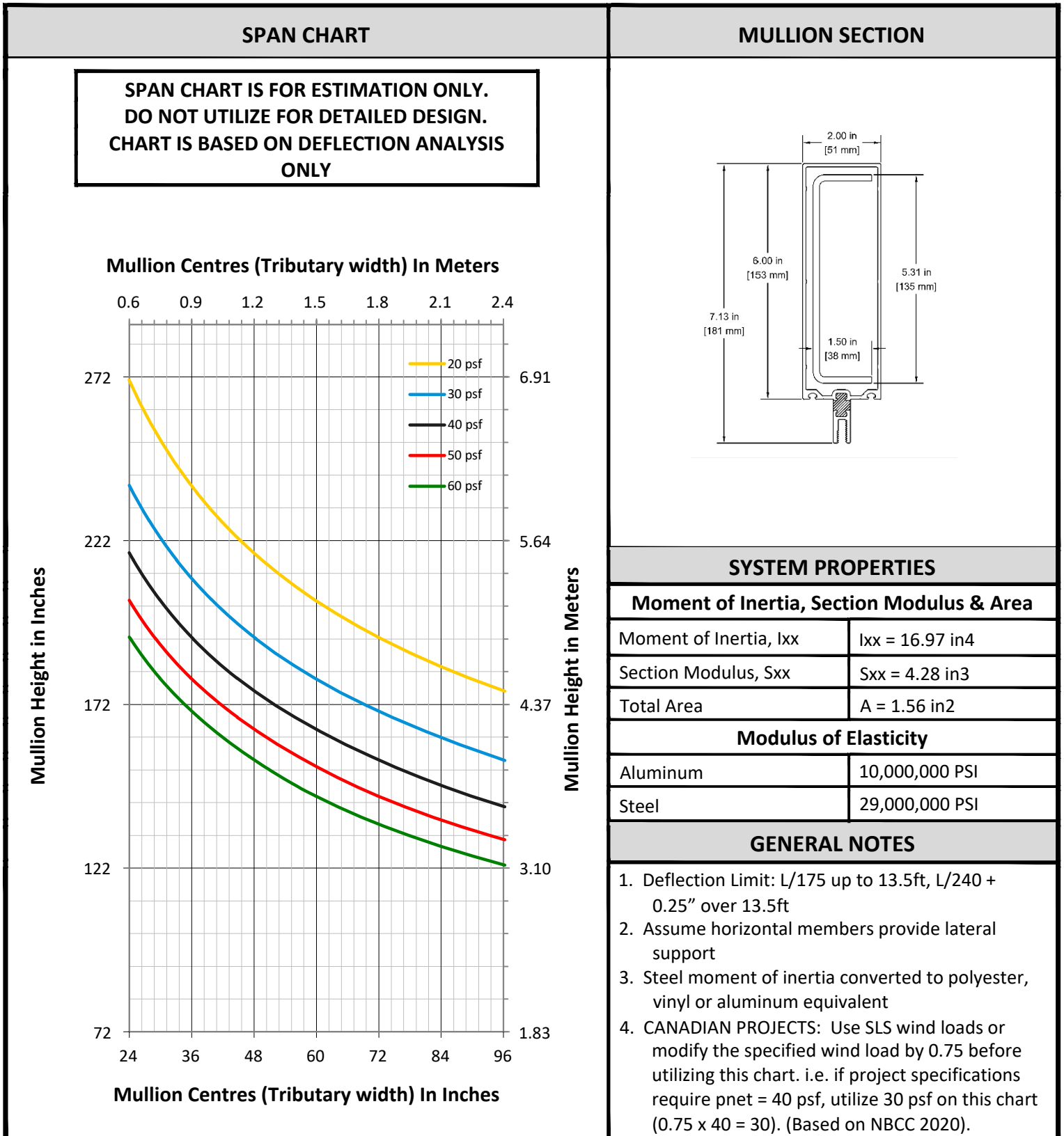

DEAD LOAD CHART FOR 2" x 6" MULLION - PART # 2426ST

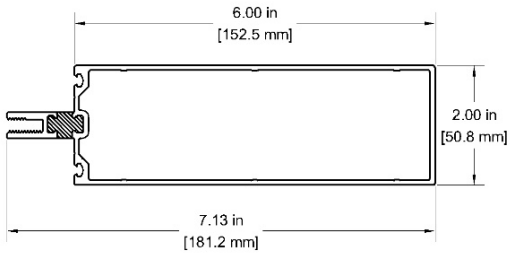
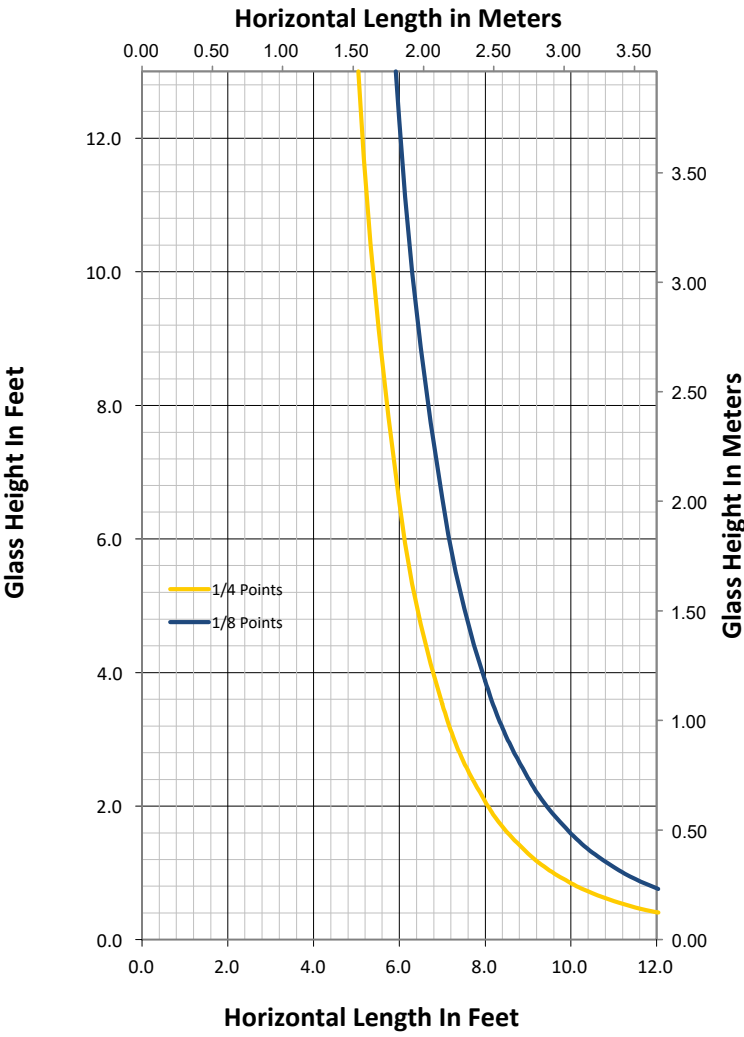
SPAN CHART	MULLION SECTION																				
<p>SPAN CHART IS FOR ESTIMATION ONLY. DO NOT UTILIZE FOR DETAILED DESIGN. CHART IS BASED ON DEFLECTION ANALYSIS ONLY</p>																					
 <p>Horizontal Length in Meters</p> <p>Glass Height In Feet</p> <p>Glass Height In Meters</p> <p>Horizontal Length In Feet</p> <p>— 1/4 Points — 1/8 Points</p>	<table border="1" style="width: 100%; border-collapse: collapse;"> <thead> <tr style="background-color: #cccccc;"> <th colspan="2" style="text-align: center;">SYSTEM PROPERTIES</th> </tr> </thead> <tbody> <tr> <th colspan="2" style="text-align: center;">Moment of Inertia, Section Modulus & Area</th> </tr> <tr> <td>Moment of Inertia, I_{yy}</td> <td>$I_{yy} = 1.01 \text{ in}^4$</td> </tr> <tr> <td>Section Modulus, S_{yy}</td> <td>$S_{yy} = 1.00 \text{ in}^3$</td> </tr> <tr> <td>Total Area</td> <td>$A = 1.56 \text{ in}^2$</td> </tr> <tr> <th colspan="2" style="text-align: center;">Modulus of Elasticity</th> </tr> <tr> <td>Aluminum</td> <td>10,000,000 PSI</td> </tr> <tr> <td>Steel</td> <td>29,000,000 PSI</td> </tr> <tr> <th colspan="2" style="text-align: center;">GENERAL NOTES</th> </tr> <tr> <td colspan="2"> <ol style="list-style-type: none"> 1. Deflection Limit: 0.125" (3.2mm). 2. Charts are calculated assuming a 1" overall sealed unit (6mm/13mm spacer/6mm) 3. Calculations are based on the position of the setting blocks being placed at 1/4 or 1/8 points. </td> </tr> </tbody> </table>	SYSTEM PROPERTIES		Moment of Inertia, Section Modulus & Area		Moment of Inertia, I_{yy}	$I_{yy} = 1.01 \text{ in}^4$	Section Modulus, S_{yy}	$S_{yy} = 1.00 \text{ in}^3$	Total Area	$A = 1.56 \text{ in}^2$	Modulus of Elasticity		Aluminum	10,000,000 PSI	Steel	29,000,000 PSI	GENERAL NOTES		<ol style="list-style-type: none"> 1. Deflection Limit: 0.125" (3.2mm). 2. Charts are calculated assuming a 1" overall sealed unit (6mm/13mm spacer/6mm) 3. Calculations are based on the position of the setting blocks being placed at 1/4 or 1/8 points. 	
SYSTEM PROPERTIES																					
Moment of Inertia, Section Modulus & Area																					
Moment of Inertia, I_{yy}	$I_{yy} = 1.01 \text{ in}^4$																				
Section Modulus, S_{yy}	$S_{yy} = 1.00 \text{ in}^3$																				
Total Area	$A = 1.56 \text{ in}^2$																				
Modulus of Elasticity																					
Aluminum	10,000,000 PSI																				
Steel	29,000,000 PSI																				
GENERAL NOTES																					
<ol style="list-style-type: none"> 1. Deflection Limit: 0.125" (3.2mm). 2. Charts are calculated assuming a 1" overall sealed unit (6mm/13mm spacer/6mm) 3. Calculations are based on the position of the setting blocks being placed at 1/4 or 1/8 points. 																					



**METRO
ALUMINUM**
Products Ltd.

2400THP SERIES
TRIPLE GLAZED - THERMALLY BROKEN
CURTAIN WALL & WINDOW SYSTEM
NARROW - 2" (50.8 mm) - FRAME

D

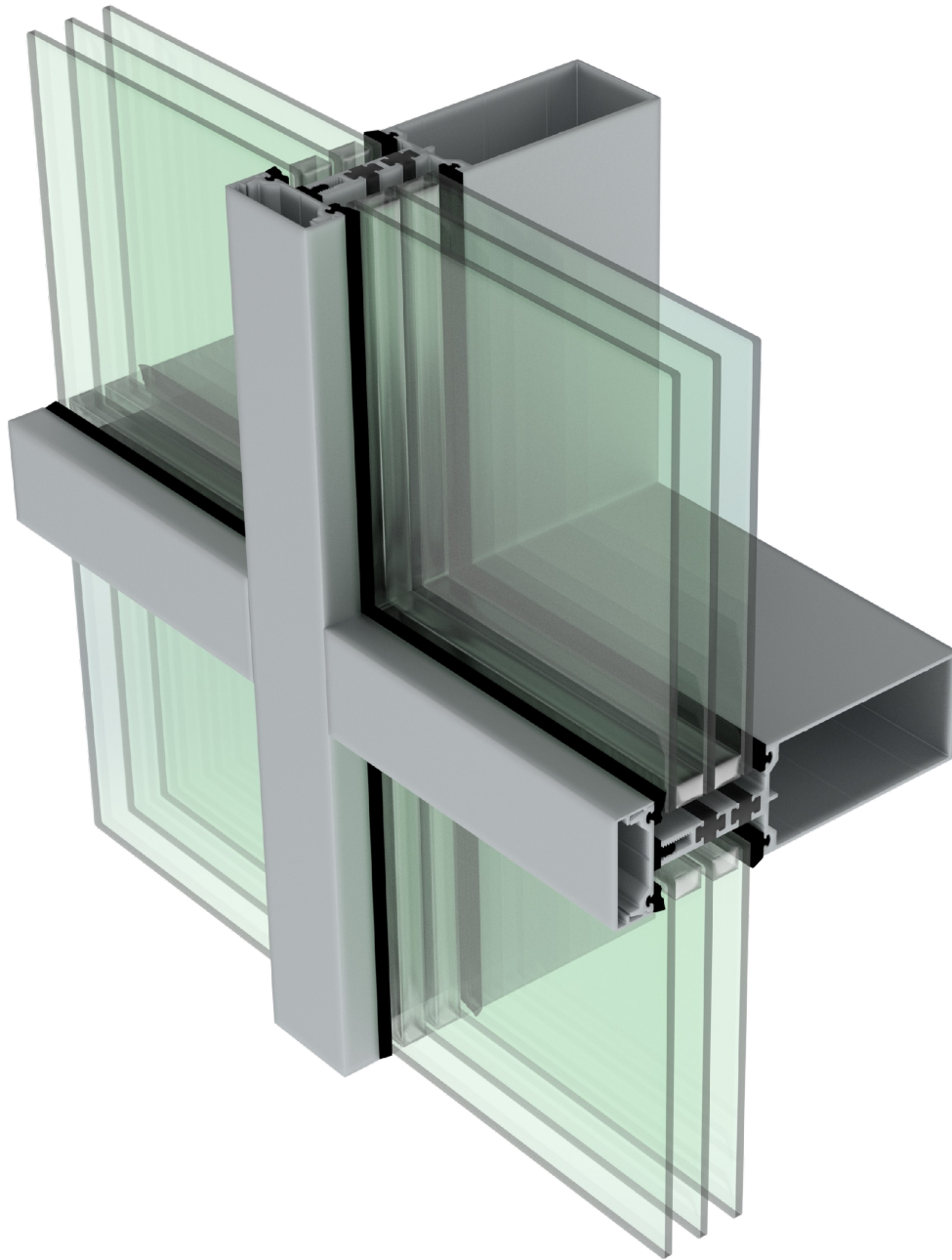



BACK SECTIONS & CAPS

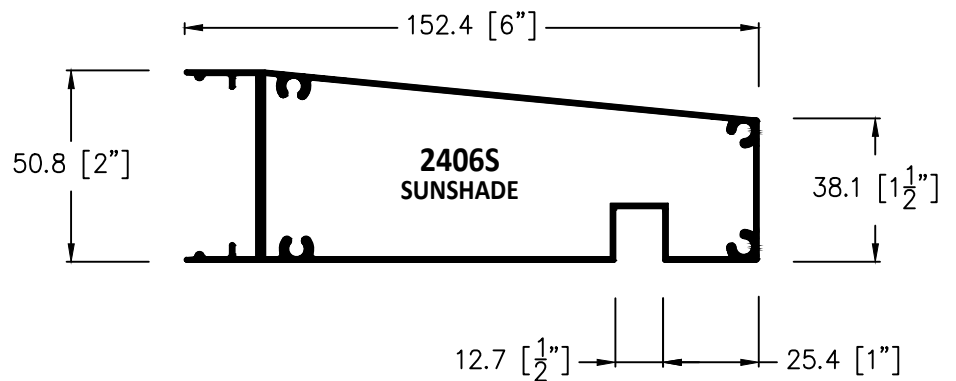
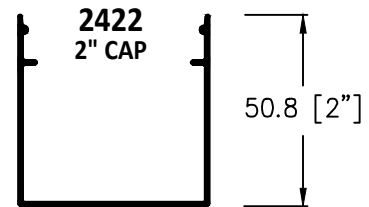
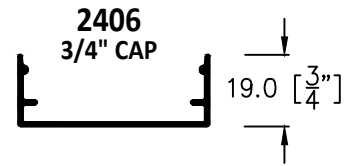
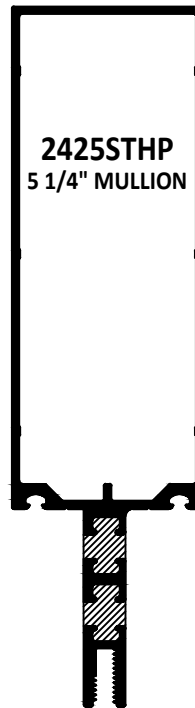
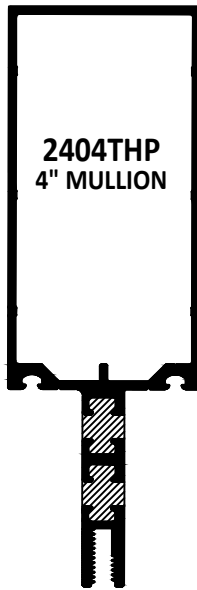



**METRO
ALUMINUM**
Products Ltd.

2400THP SERIES
TRIPLE GLAZED - THERMALLY BROKEN
CURTAIN WALL & WINDOW SYSTEM
NARROW - 2" (50.8 mm) - FRAME

**D
26**

SSG & CORNERS

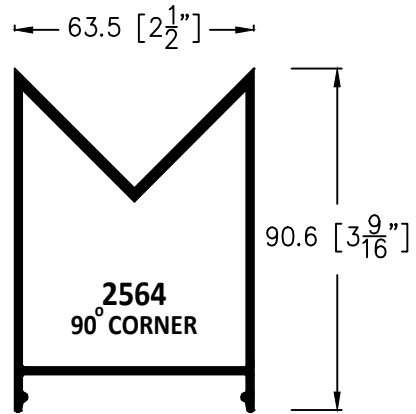

EXTENSION CAP FOR 4" BACK

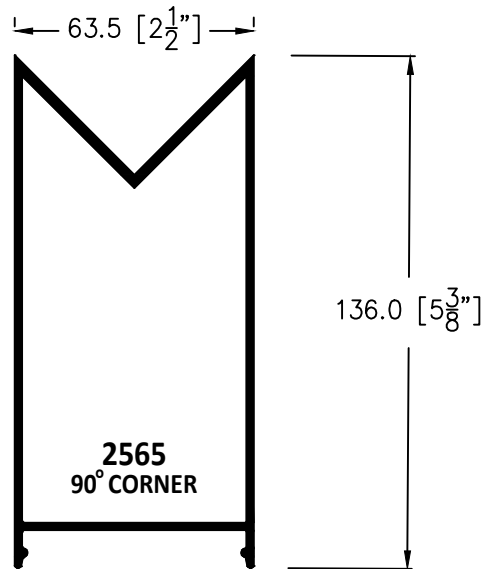

EXTENSION CAP FOR 5 1/4" BACK

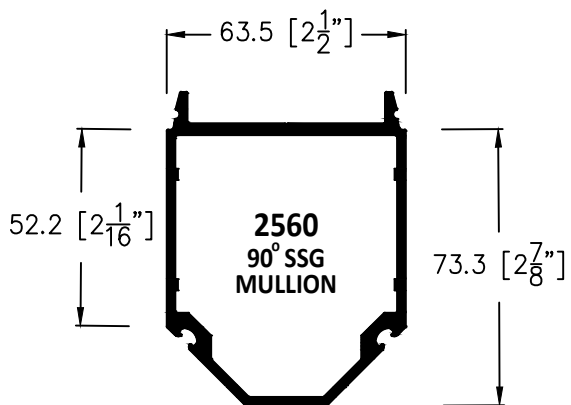



MISC. COMPONENTS



2410
THERMAL BREAK



2415-3
CORNER BLOCK



2460
SPONGE GASKET
(INTERIOR)



2450
DENSE GASKET
(EXTERIOR)

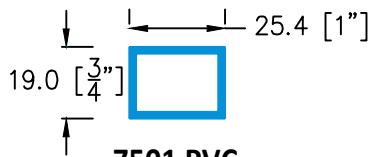

7501 PVC
ANTI-ROTATION

2435
DOOR
ADAPTER

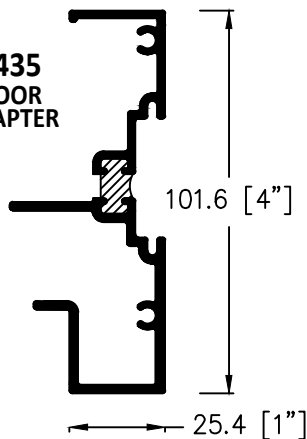

2420
SPIGOT

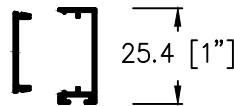
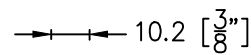

2417/2418
SURFACE APPLIED
DOOR STOP



20120T
DOOR STOP
FOR 2" DOORS



2012T
DOOR STOP
FOR 1 3/4" DOORS



2430
BACK-PAN
ADAPTOR



5100
1" X 1" PERIMETER ANGLE



5102
1" X 2" PERIMETER ANGLE



5103
1" X 3" PERIMETER ANGLE

TYPICAL DETAILS

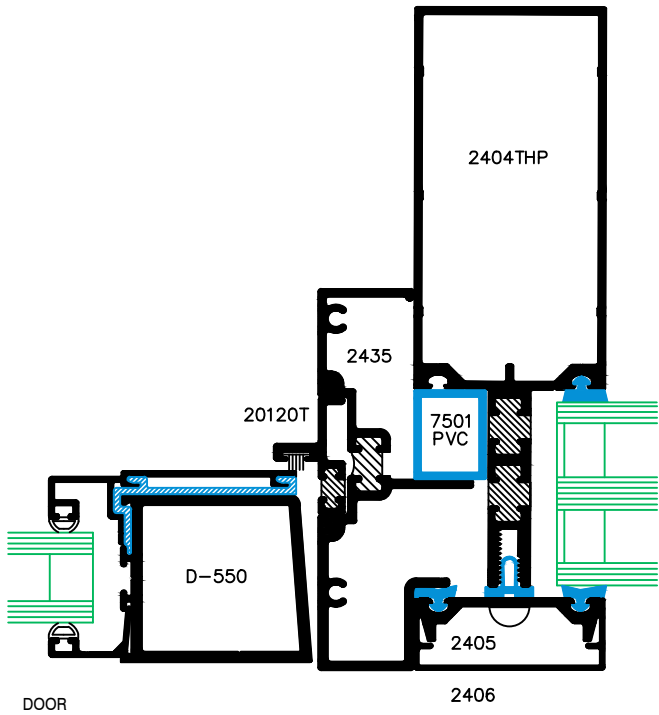

1a

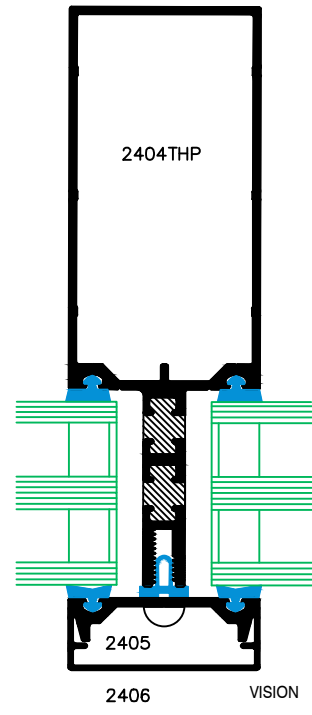

2

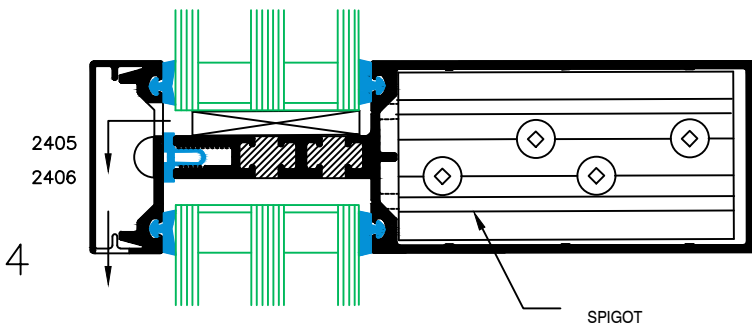

4

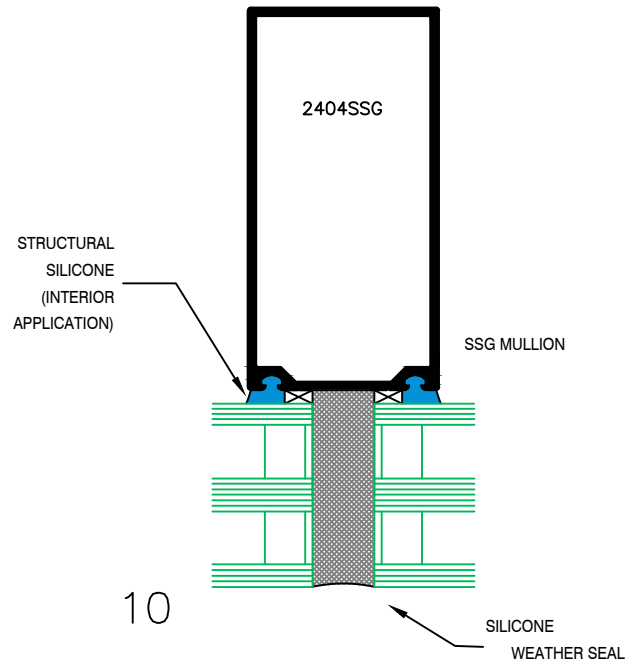

10

TYPICAL CURTAIN WALL VENT DETAILS

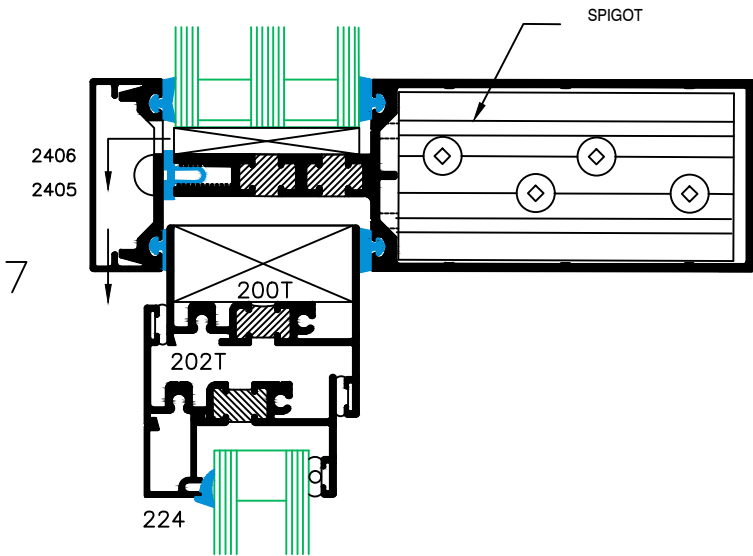

200T SERIES VENT
OPEN-OUT
OUTSIDE GLAZED

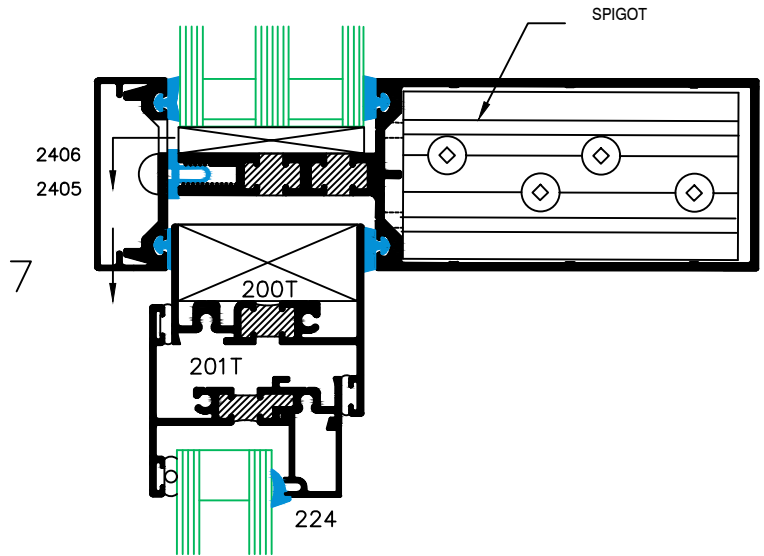

200T SERIES VENT
OPEN-OUT
INSIDE GLAZED

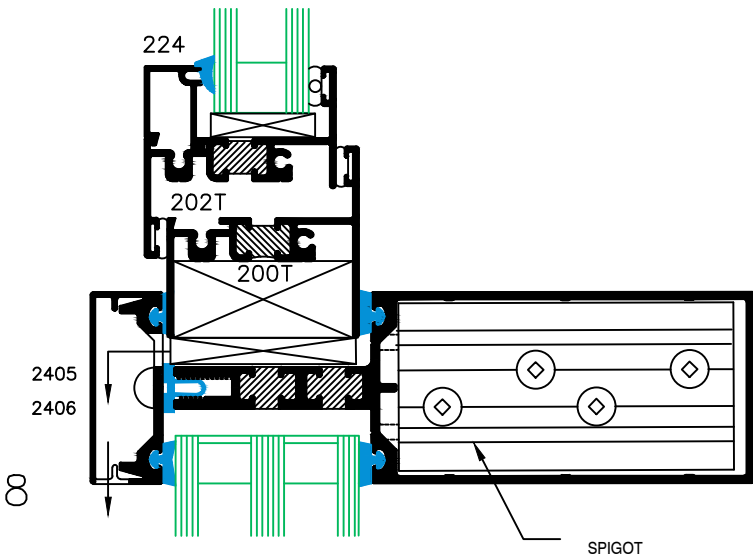

SPIGOT

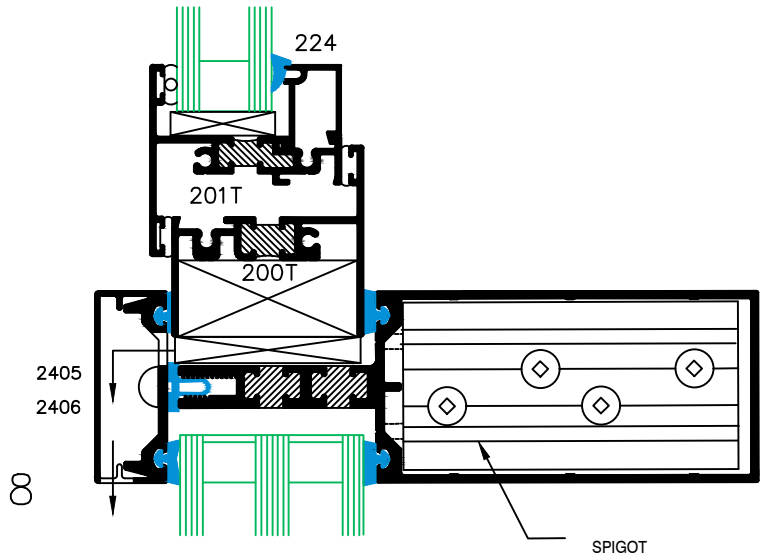

SPIGOT



**METRO
ALUMINUM**
Products Ltd.

2400THP SERIES
TRIPLE GLAZED - THERMALLY BROKEN
CURTAIN WALL & WINDOW SYSTEM
NARROW - 2" (50.8 mm) - FRAME

**D
28B**

TYPICAL CAPTURED CORNER DETAILS

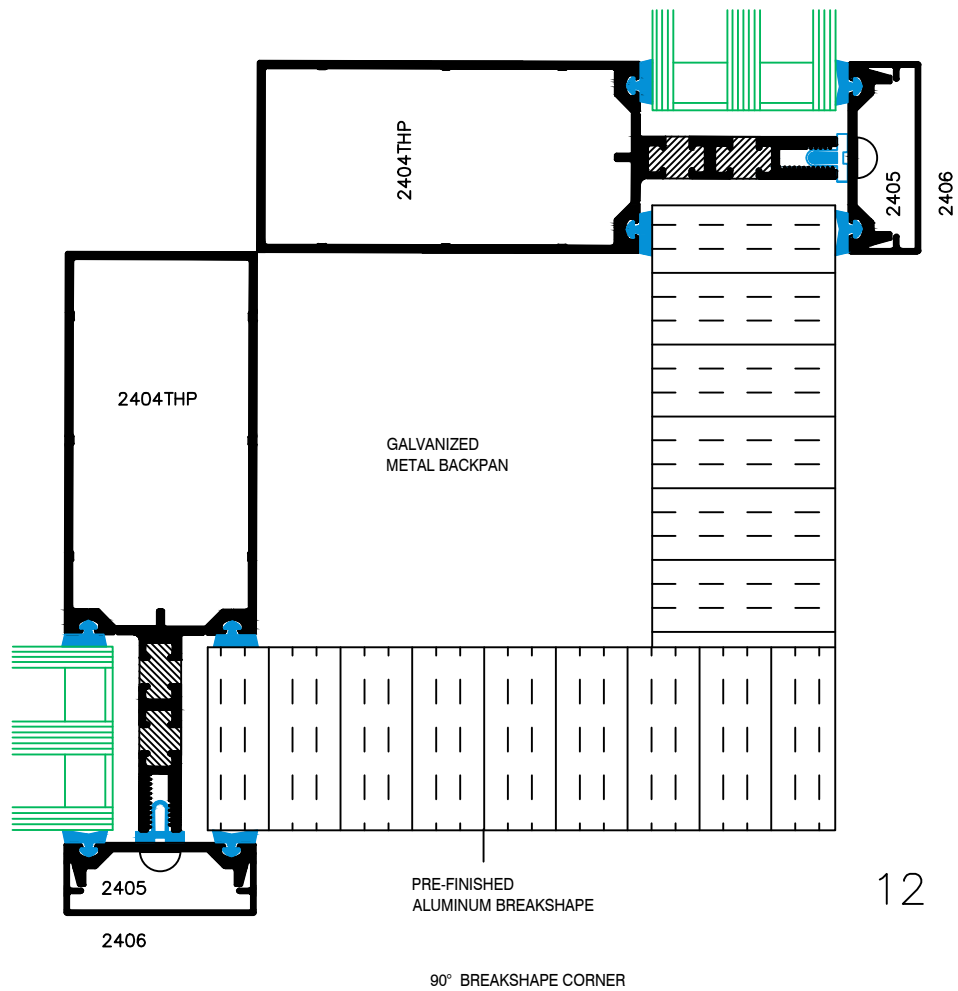

TYPICAL BUTT-JOINT CORNER DETAILS

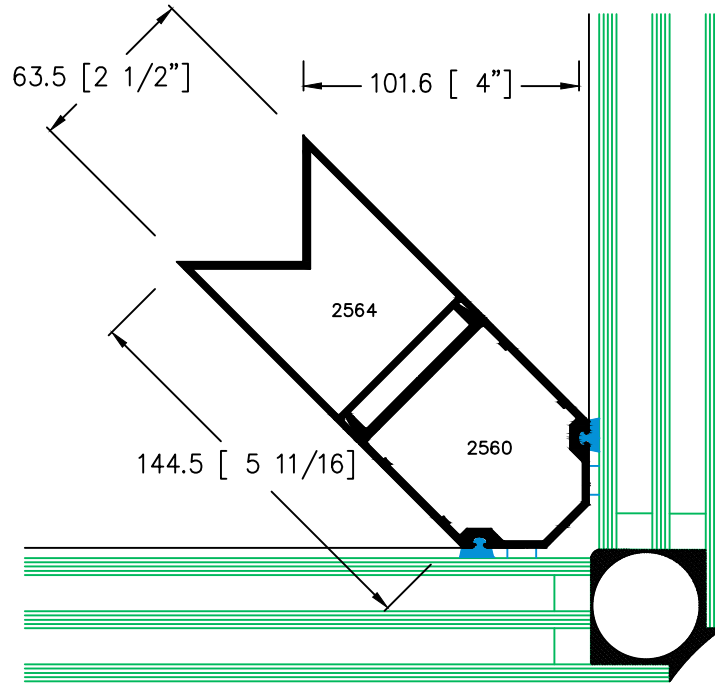

90° BUTT-JOINT CORNER
AT 4" BACK MEMBER

13

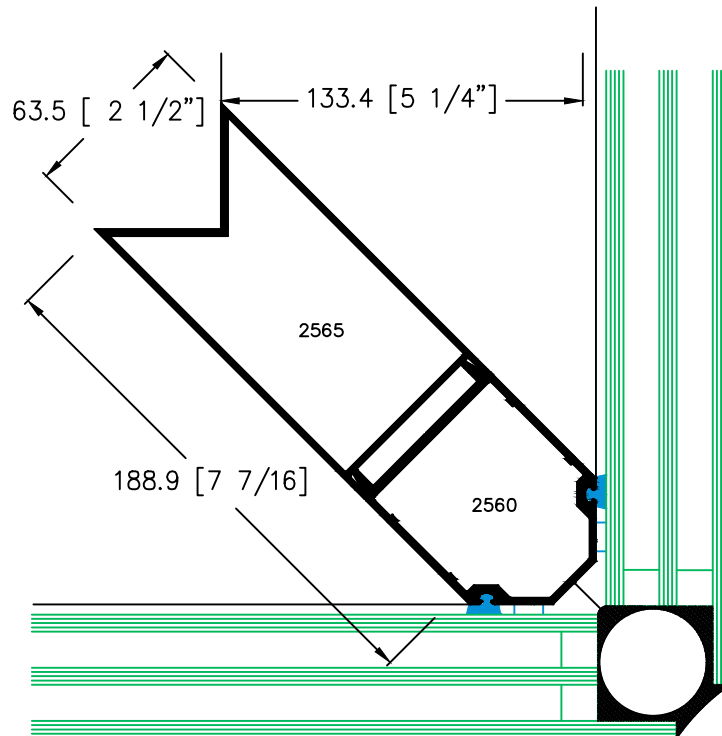

90° BUTT-JOINT CORNER
AT 5 1/4" BACK MEMBER

14

ALTERNATE DOOR DETAILS

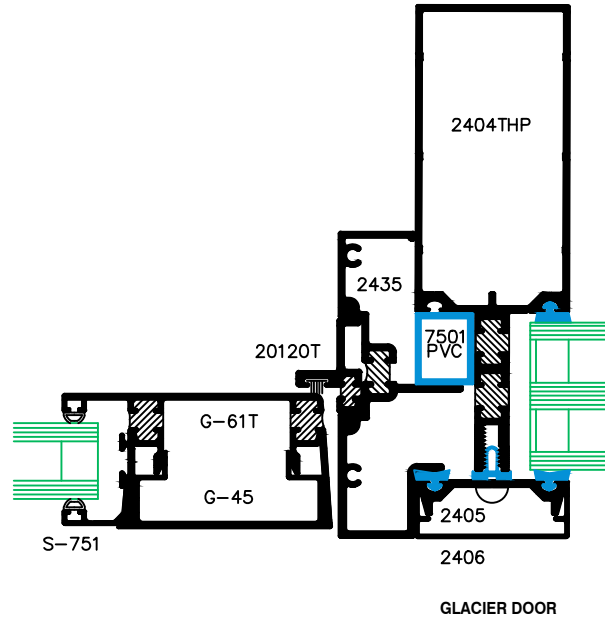

15a

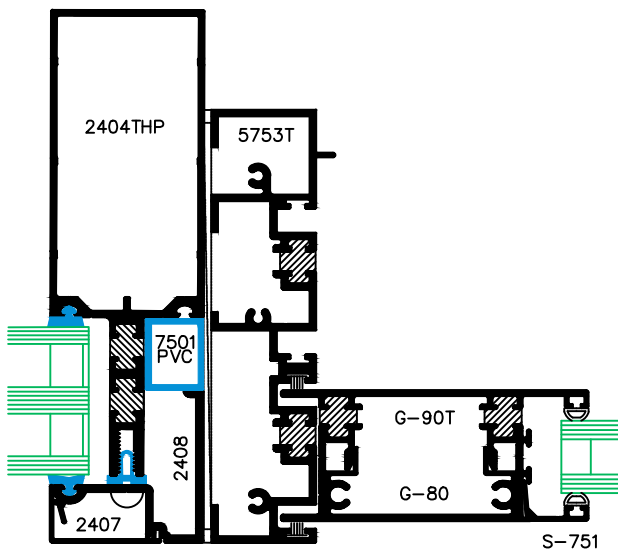

1100T JAMB AT SLIDER

16

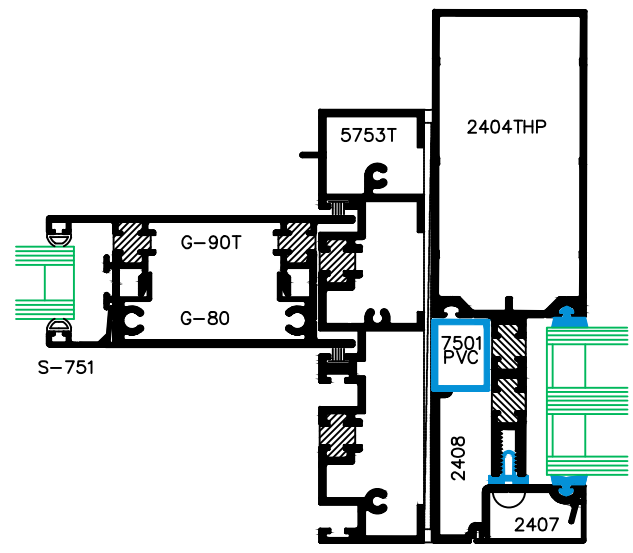

1100T JAMB AT FIXED PANEL

16a

SLIDING DOORS



**METRO
ALUMINUM**
Products Ltd.

2400THP SERIES
TRIPLE GLAZED - THERMALLY BROKEN
CURTAIN WALL & WINDOW SYSTEM
NARROW - 2" (50.8 mm) - FRAME

**D
28E**

**INTERFACE DETAILS
(SUGGESTED ONLY)**

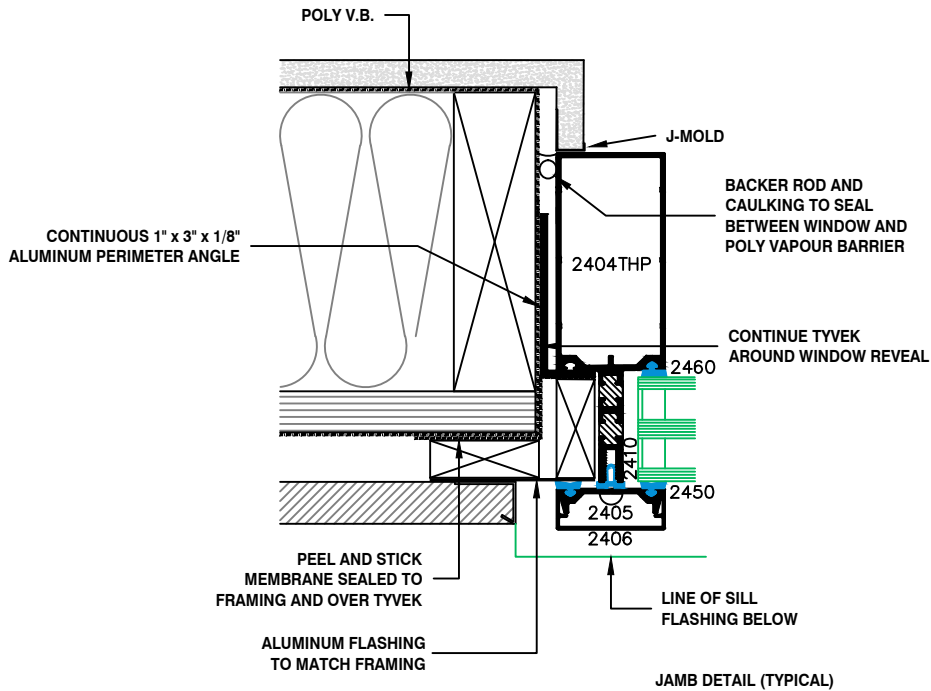
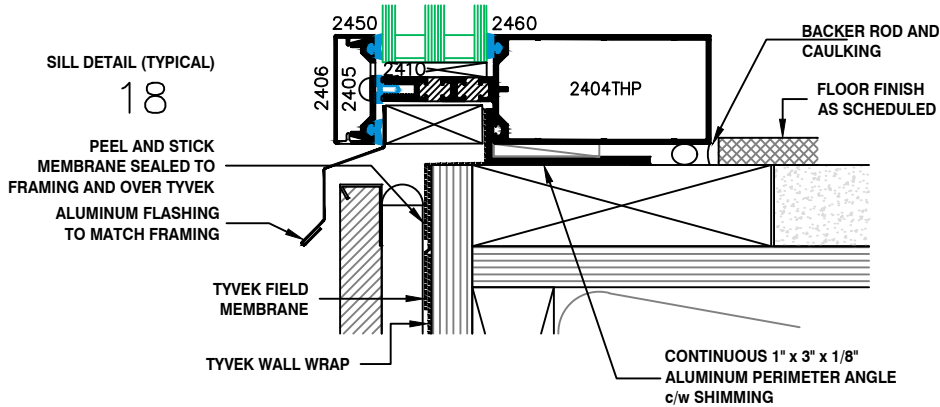
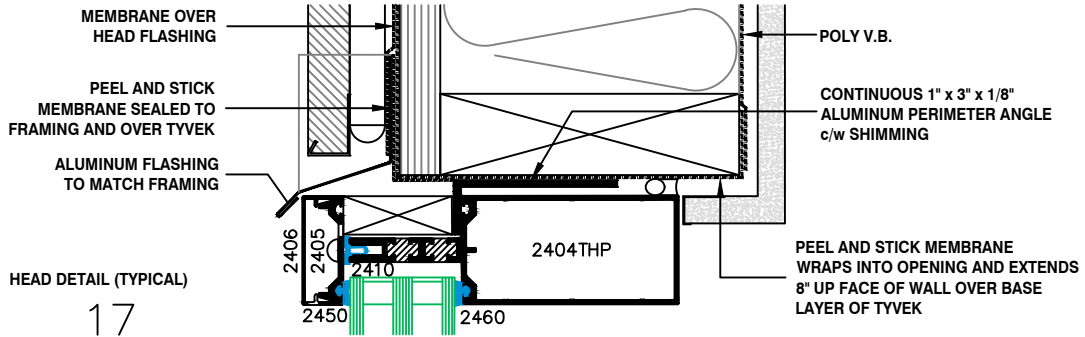



**METRO
ALUMINUM**
Products Ltd.

2400THP SERIES
TRIPLE GLAZED - THERMALLY BROKEN
CURTAIN WALL & WINDOW SYSTEM
NARROW - 2" (50.8 mm) - FRAME

**D
28F**

TYPICAL ANCHORING DETAILS

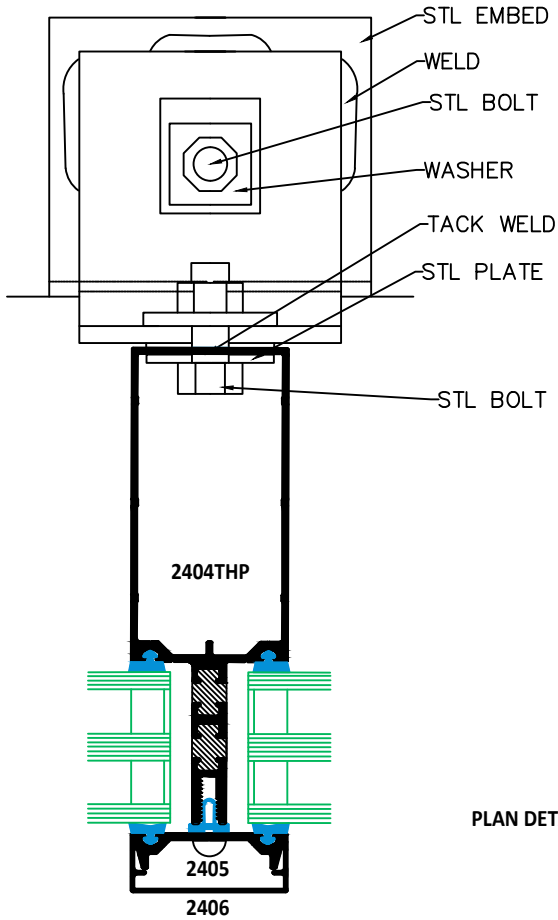

PLAN DETAILS

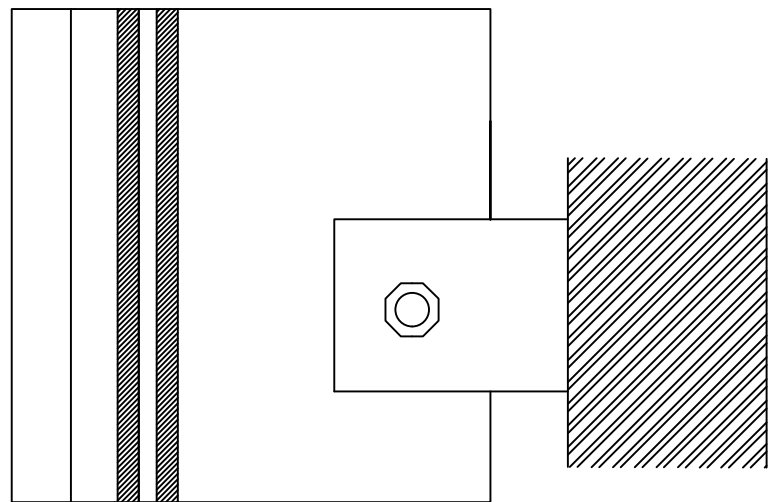
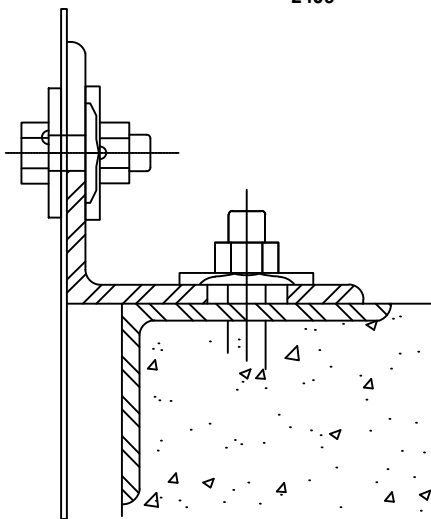
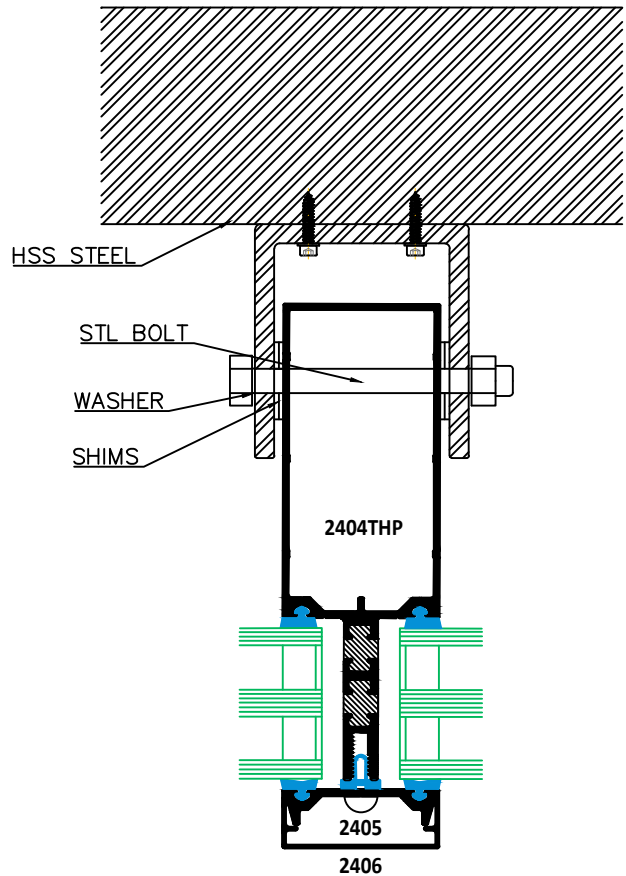

SECTION DETAILS



**METRO
ALUMINUM**
Products Ltd.

2400THP SERIES
TRIPLE GLAZED - THERMALLY BROKEN
CURTAIN WALL & WINDOW SYSTEM
NARROW - 2" (50.8 mm) - FRAME

**D
28G**

EXPANSION & SPLICE DETAILS

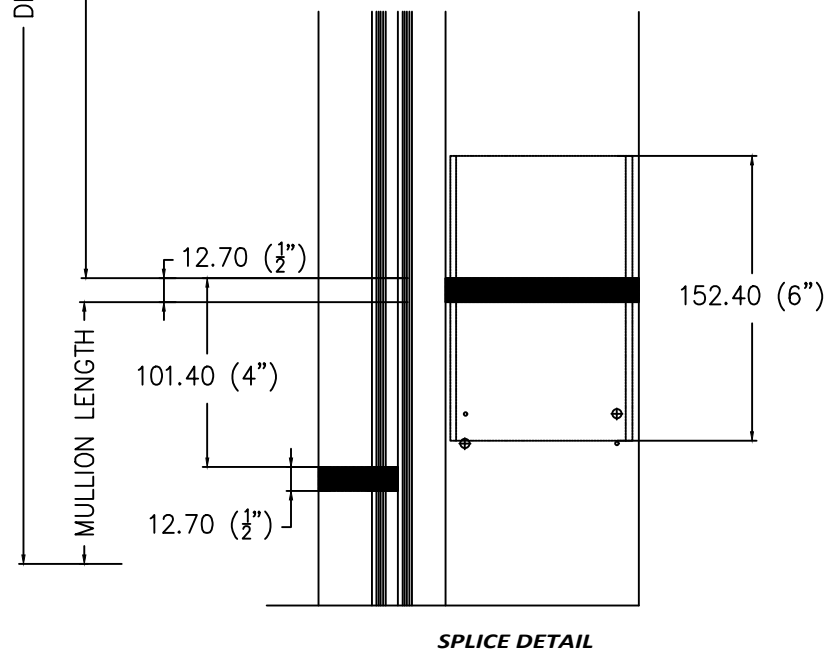
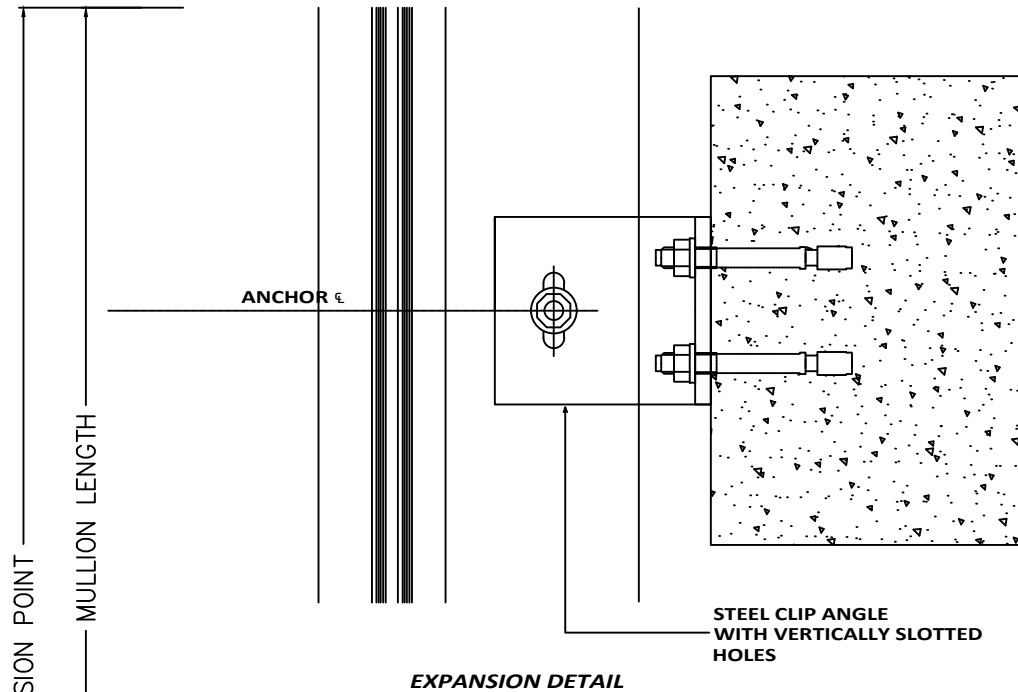

WIND LOAD CHART FOR 2" x 4" T/G MULLION - PART # 2404THP

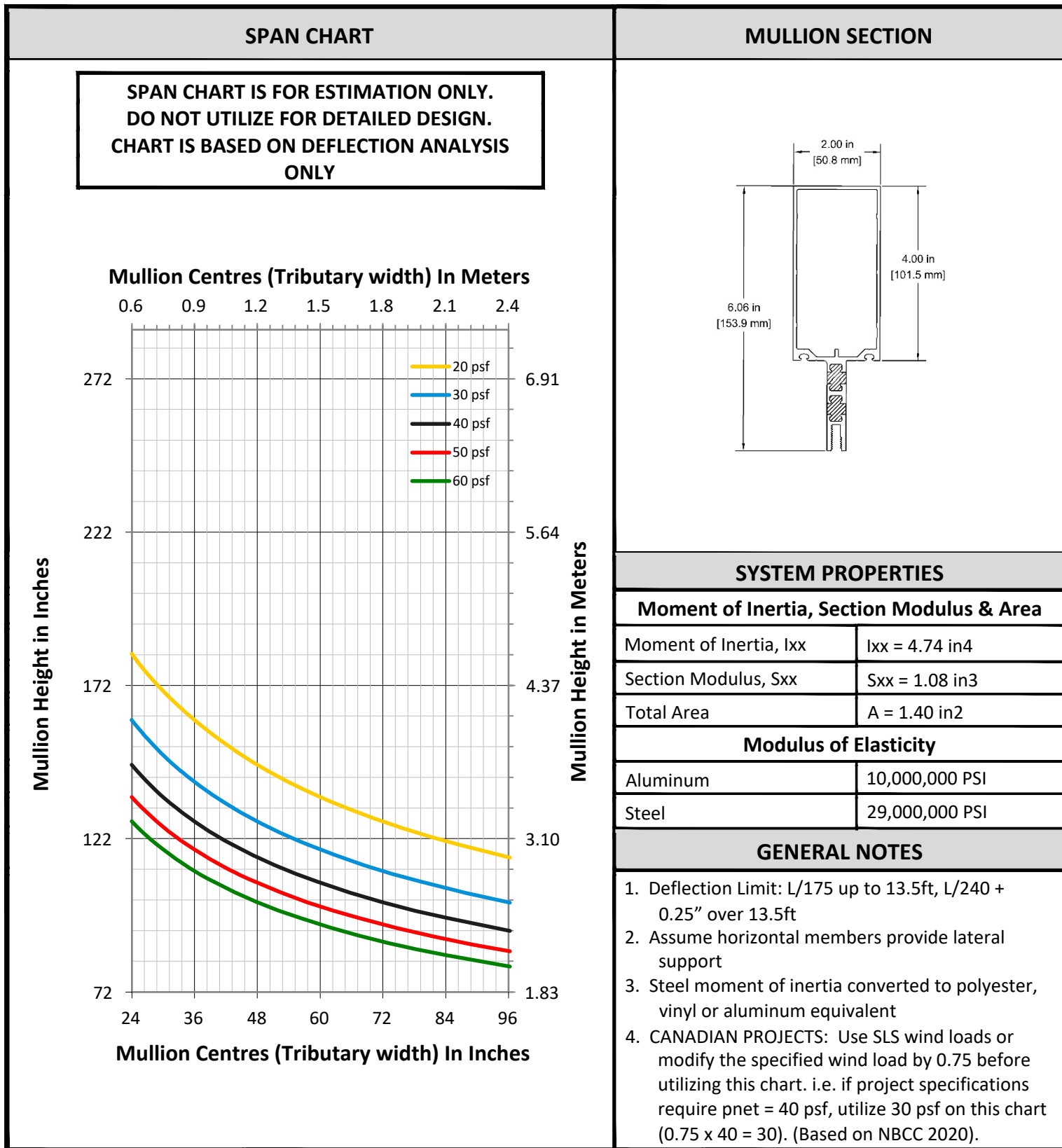

STEEL LOADED WIND LOAD CHART FOR 2" x 4" T/G MULLION - PART # 2404THP

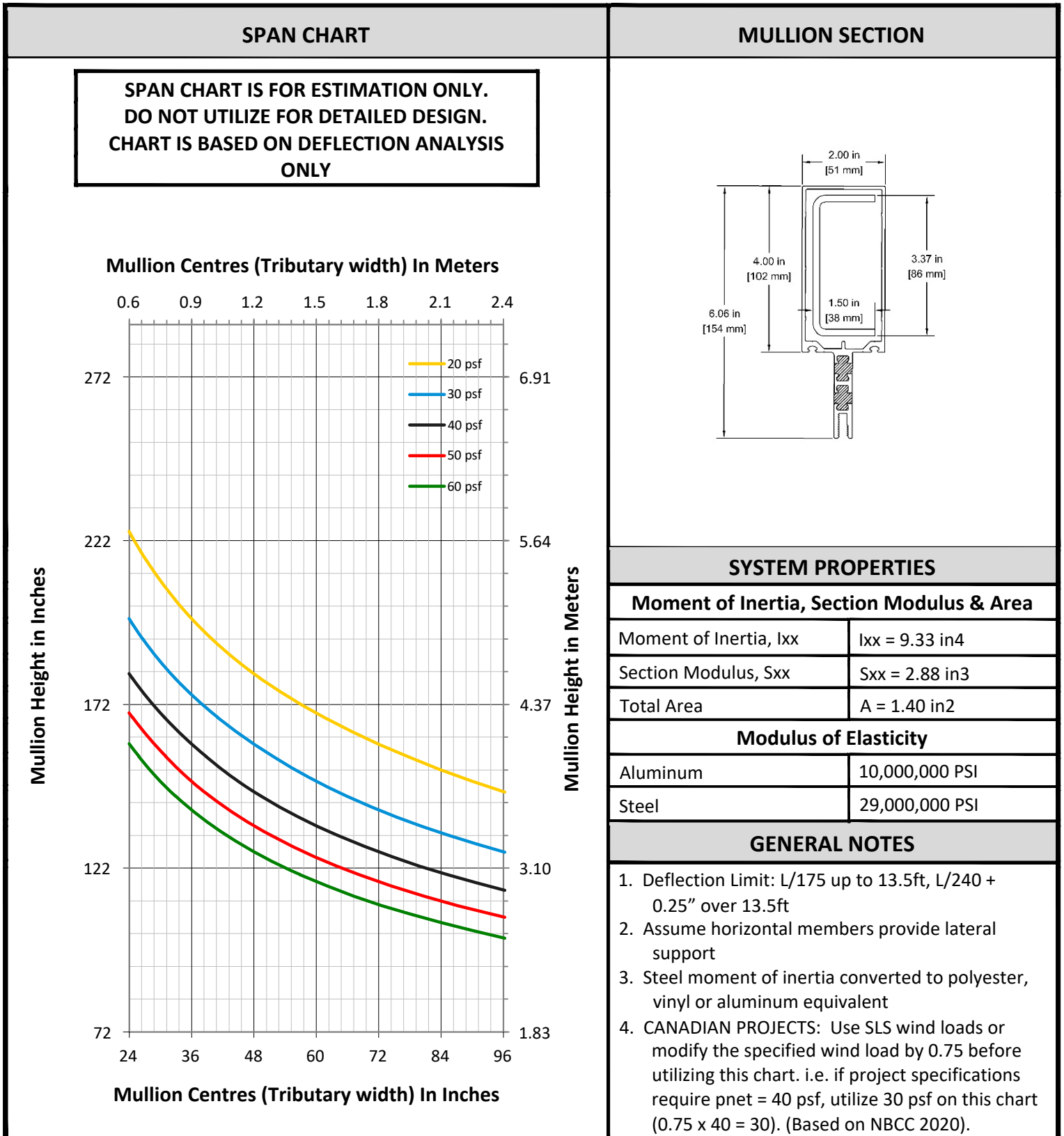

DEAD LOAD CHART FOR 2" x 4" T/G MULLION - PART # 2404THP

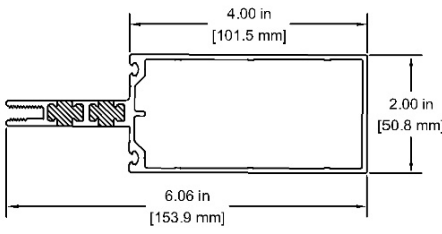
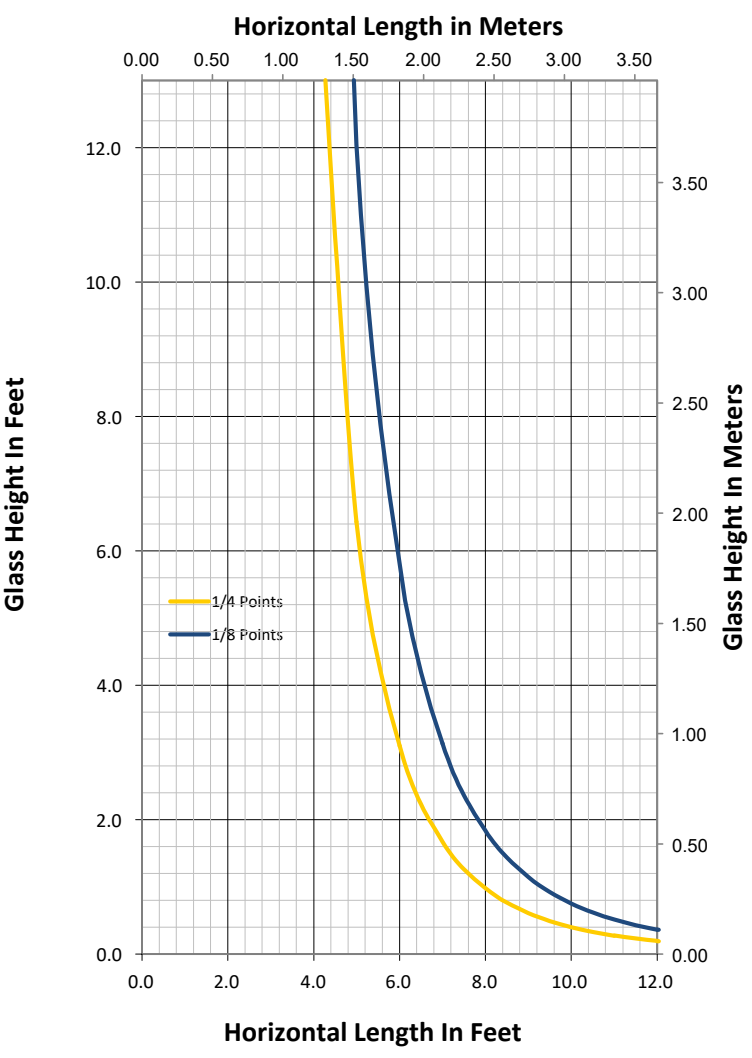
SPAN CHART	MULLION SECTION																				
<p>SPAN CHART IS FOR ESTIMATION ONLY. DO NOT UTILIZE FOR DETAILED DESIGN. CHART IS BASED ON DEFLECTION ANALYSIS ONLY</p>																					
	<table border="1" style="width: 100%; border-collapse: collapse;"> <thead> <tr style="background-color: #cccccc;"> <th colspan="2" style="text-align: center;">SYSTEM PROPERTIES</th> </tr> </thead> <tbody> <tr> <th colspan="2" style="text-align: center;">Moment of Inertia, Section Modulus & Area</th> </tr> <tr> <td>Moment of Inertia, I_{yy}</td> <td>$I_{yy} = 0.72 \text{ in}^4$</td> </tr> <tr> <td>Section Modulus, S_{yy}</td> <td>$S_{yy} = 0.71 \text{ in}^3$</td> </tr> <tr> <td>Total Area</td> <td>$A = 1.40 \text{ in}^2$</td> </tr> <tr> <th colspan="2" style="text-align: center;">Modulus of Elasticity</th> </tr> <tr> <td>Aluminum</td> <td>10,000,000 PSI</td> </tr> <tr> <td>Steel</td> <td>29,000,000 PSI</td> </tr> <tr> <th colspan="2" style="text-align: center;">GENERAL NOTES</th> </tr> <tr> <td colspan="2"> <ol style="list-style-type: none"> 1. Deflection Limit: 0.125" (3.2mm). 2. Charts are calculated assuming a 1-15/16" overall sealed unit (6mm/18mm spacer/6mm/13mm spacer/6mm). 3. Calculations are based on the position of the setting blocks being placed at 1/4 or 1/8 points. </td> </tr> </tbody> </table>	SYSTEM PROPERTIES		Moment of Inertia, Section Modulus & Area		Moment of Inertia, I_{yy}	$I_{yy} = 0.72 \text{ in}^4$	Section Modulus, S_{yy}	$S_{yy} = 0.71 \text{ in}^3$	Total Area	$A = 1.40 \text{ in}^2$	Modulus of Elasticity		Aluminum	10,000,000 PSI	Steel	29,000,000 PSI	GENERAL NOTES		<ol style="list-style-type: none"> 1. Deflection Limit: 0.125" (3.2mm). 2. Charts are calculated assuming a 1-15/16" overall sealed unit (6mm/18mm spacer/6mm/13mm spacer/6mm). 3. Calculations are based on the position of the setting blocks being placed at 1/4 or 1/8 points. 	
SYSTEM PROPERTIES																					
Moment of Inertia, Section Modulus & Area																					
Moment of Inertia, I_{yy}	$I_{yy} = 0.72 \text{ in}^4$																				
Section Modulus, S_{yy}	$S_{yy} = 0.71 \text{ in}^3$																				
Total Area	$A = 1.40 \text{ in}^2$																				
Modulus of Elasticity																					
Aluminum	10,000,000 PSI																				
Steel	29,000,000 PSI																				
GENERAL NOTES																					
<ol style="list-style-type: none"> 1. Deflection Limit: 0.125" (3.2mm). 2. Charts are calculated assuming a 1-15/16" overall sealed unit (6mm/18mm spacer/6mm/13mm spacer/6mm). 3. Calculations are based on the position of the setting blocks being placed at 1/4 or 1/8 points. 																					

WIND LOAD CHART FOR 2" x 4" SSG MULLION - PART # 2404SSG

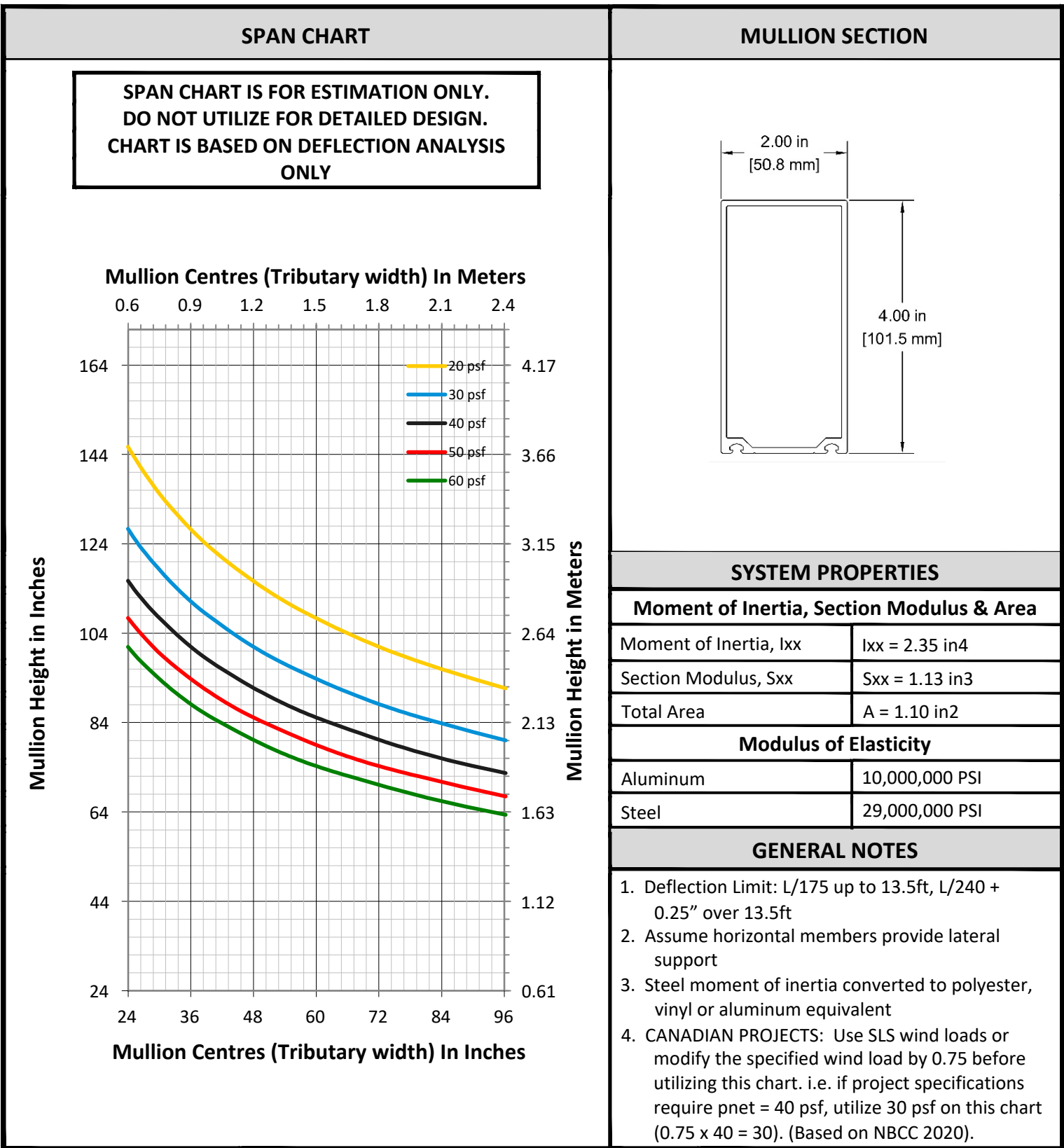

STEEL LOADED WIND LOAD CHART FOR 2" x 4" T/G SSG MULLION - PART # 2404SSG

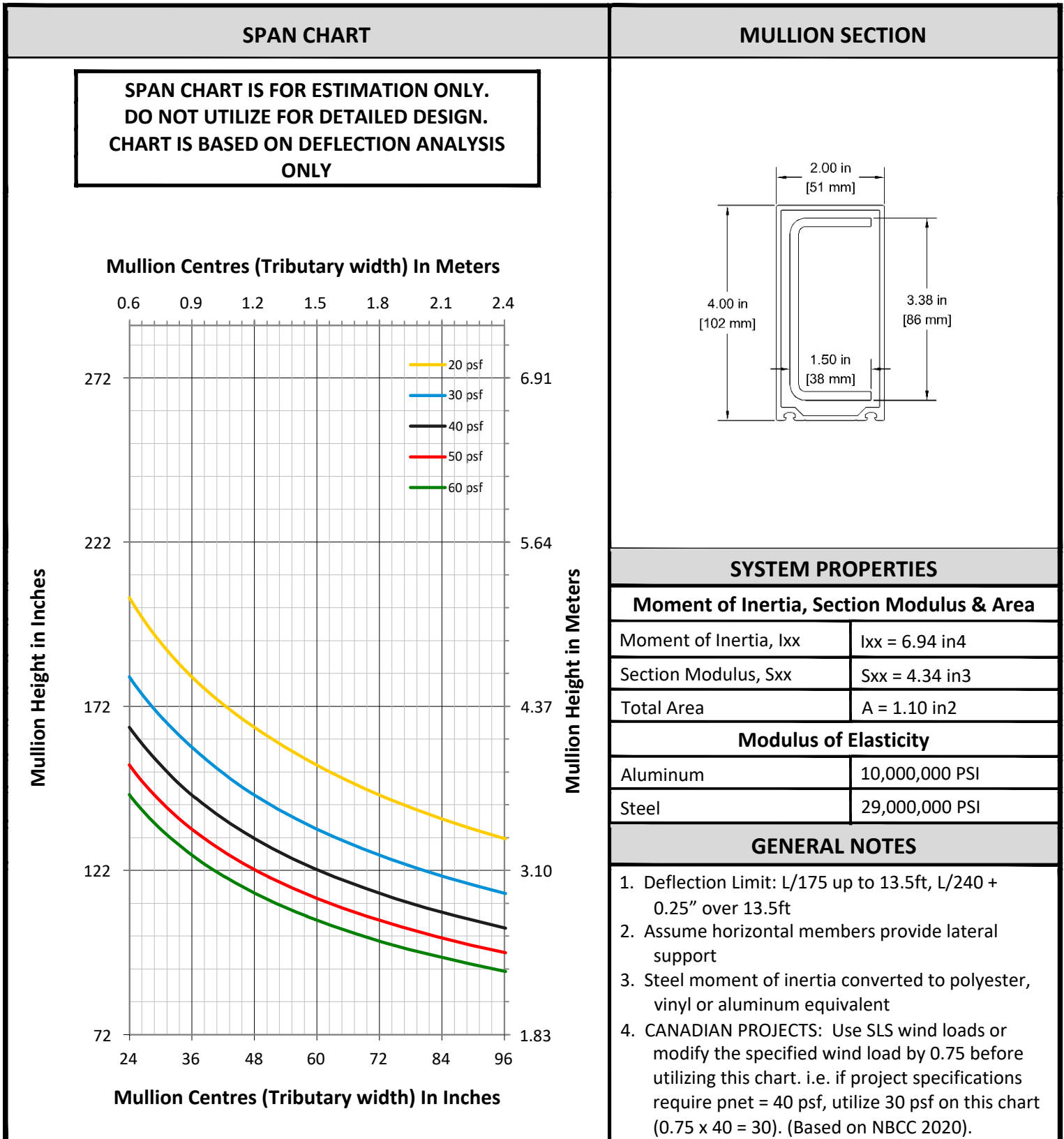

DEAD LOAD CHART FOR 2" x 4" T/G SSG MULLION - PART # 2404SSG

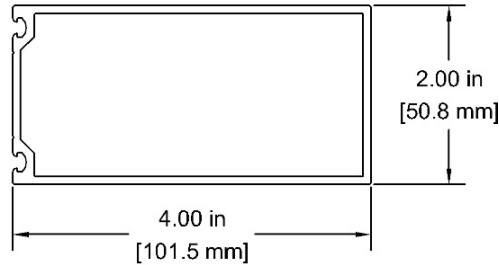
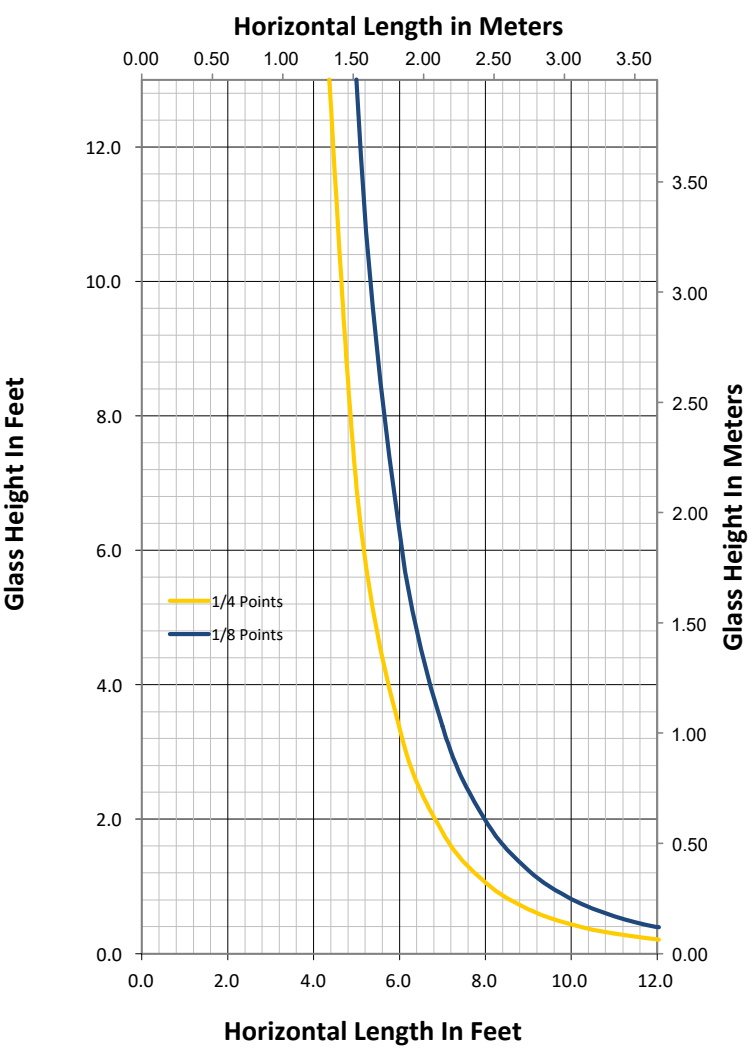
SPAN CHART	MULLION SECTION																				
<p>SPAN CHART IS FOR ESTIMATION ONLY. DO NOT UTILIZE FOR DETAILED DESIGN. CHART IS BASED ON DEFLECTION ANALYSIS ONLY</p>																					
	<table border="1" style="width: 100%; border-collapse: collapse;"> <thead> <tr style="background-color: #cccccc;"> <th colspan="2" style="text-align: center;">SYSTEM PROPERTIES</th> </tr> </thead> <tbody> <tr style="background-color: #cccccc;"> <th colspan="2" style="text-align: center;">Moment of Inertia, Section Modulus & Area</th> </tr> <tr> <td style="text-align: left;">Moment of Inertia, I_{yy}</td> <td style="text-align: right;">$I_{yy} = 0.77 \text{ in}^4$</td> </tr> <tr> <td style="text-align: left;">Section Modulus, S_{yy}</td> <td style="text-align: right;">$S_{yy} = 0.77 \text{ in}^3$</td> </tr> <tr> <td style="text-align: left;">Total Area</td> <td style="text-align: right;">$A = 1.10 \text{ in}^2$</td> </tr> <tr style="background-color: #cccccc;"> <th colspan="2" style="text-align: center;">Modulus of Elasticity</th> </tr> <tr> <td style="text-align: left;">Aluminum</td> <td style="text-align: right;">10,000,000 PSI</td> </tr> <tr> <td style="text-align: left;">Steel</td> <td style="text-align: right;">29,000,000 PSI</td> </tr> <tr style="background-color: #cccccc;"> <th colspan="2" style="text-align: center;">GENERAL NOTES</th> </tr> <tr> <td colspan="2"> <ol style="list-style-type: none"> 1. Deflection Limit: 0.125" (3.2mm). 2. Charts are calculated assuming a 1-15/16" overall sealed unit (6mm/18mm spacer/6mm/13mm spacer/6mm). 3. Calculations are based on the position of the setting blocks being placed at 1/4 or 1/8 points. </td> </tr> </tbody> </table>	SYSTEM PROPERTIES		Moment of Inertia, Section Modulus & Area		Moment of Inertia, I_{yy}	$I_{yy} = 0.77 \text{ in}^4$	Section Modulus, S_{yy}	$S_{yy} = 0.77 \text{ in}^3$	Total Area	$A = 1.10 \text{ in}^2$	Modulus of Elasticity		Aluminum	10,000,000 PSI	Steel	29,000,000 PSI	GENERAL NOTES		<ol style="list-style-type: none"> 1. Deflection Limit: 0.125" (3.2mm). 2. Charts are calculated assuming a 1-15/16" overall sealed unit (6mm/18mm spacer/6mm/13mm spacer/6mm). 3. Calculations are based on the position of the setting blocks being placed at 1/4 or 1/8 points. 	
SYSTEM PROPERTIES																					
Moment of Inertia, Section Modulus & Area																					
Moment of Inertia, I_{yy}	$I_{yy} = 0.77 \text{ in}^4$																				
Section Modulus, S_{yy}	$S_{yy} = 0.77 \text{ in}^3$																				
Total Area	$A = 1.10 \text{ in}^2$																				
Modulus of Elasticity																					
Aluminum	10,000,000 PSI																				
Steel	29,000,000 PSI																				
GENERAL NOTES																					
<ol style="list-style-type: none"> 1. Deflection Limit: 0.125" (3.2mm). 2. Charts are calculated assuming a 1-15/16" overall sealed unit (6mm/18mm spacer/6mm/13mm spacer/6mm). 3. Calculations are based on the position of the setting blocks being placed at 1/4 or 1/8 points. 																					

WIND LOAD CHART FOR 2" x 5 1/4" T/G MULLION - PART # 2425STHP

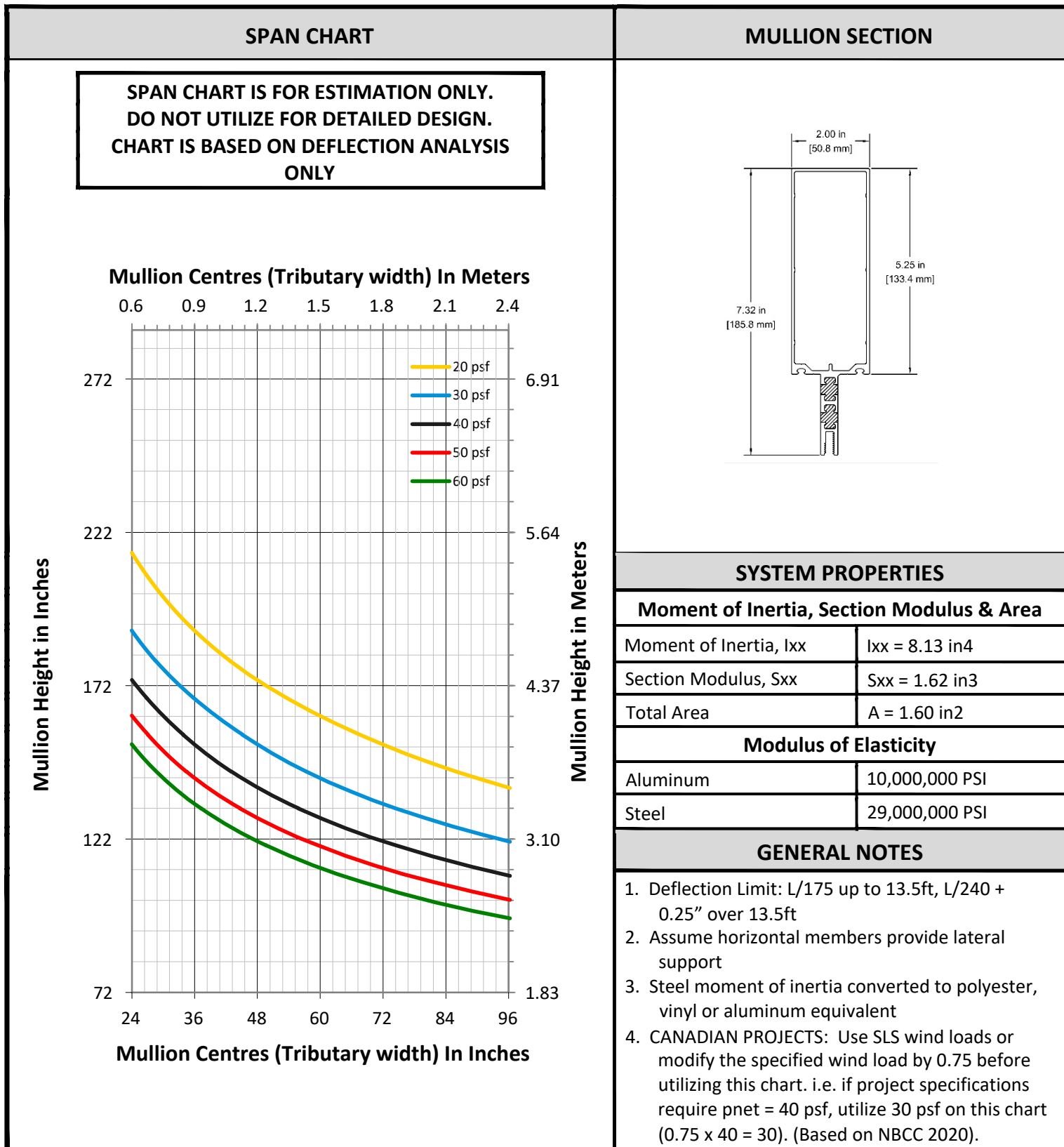

STEEL LOADED WIND LOAD CHART FOR 2" x 5 1/4" T/G MULLION - PART # 2425STHP

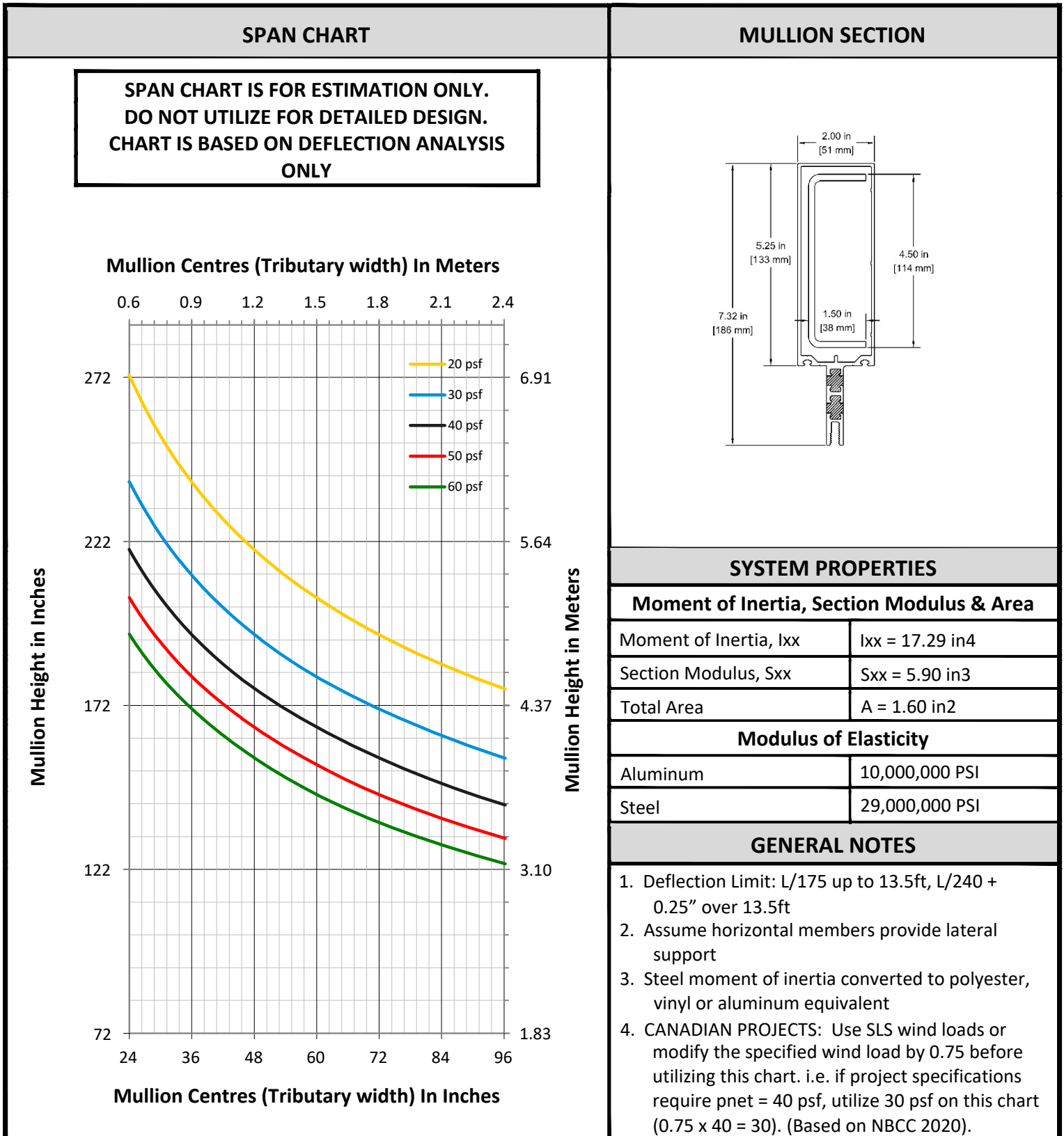

DEAD LOAD CHART FOR 2" x 5 1/4" T/G MULLION - PART # 2425STHP

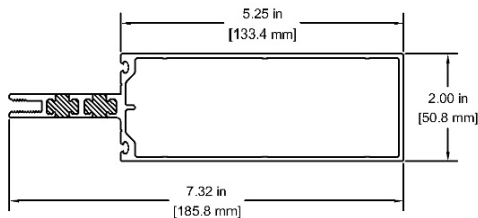
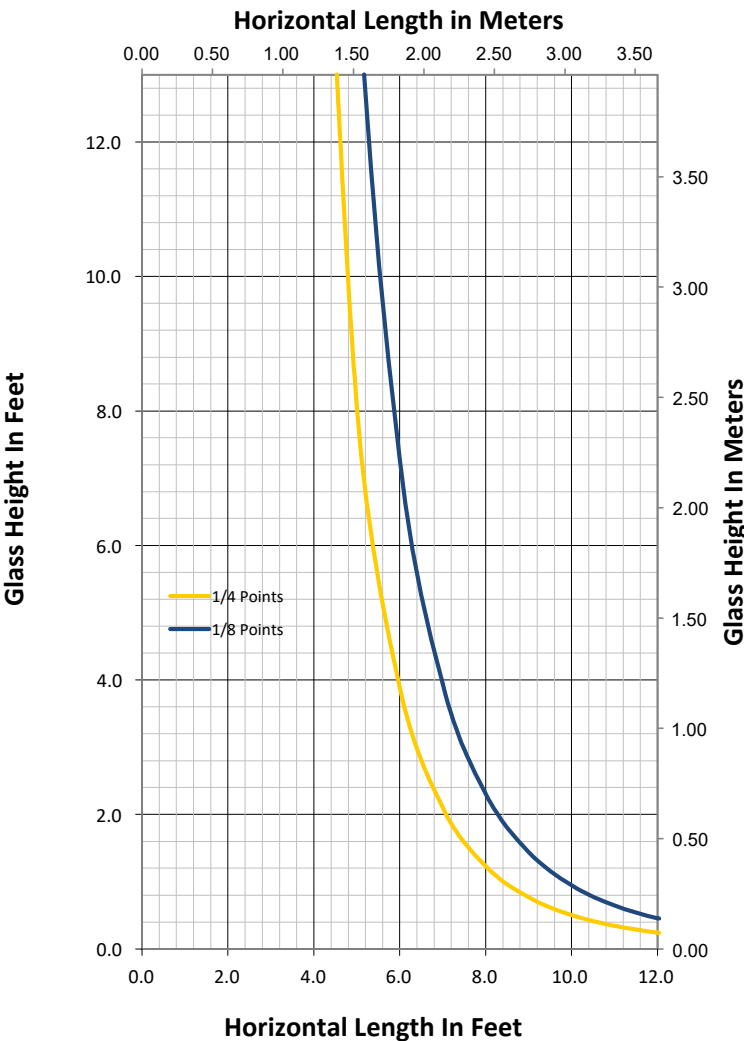
SPAN CHART	MULLION SECTION																				
<p>SPAN CHART IS FOR ESTIMATION ONLY. DO NOT UTILIZE FOR DETAILED DESIGN. CHART IS BASED ON DEFLECTION ANALYSIS ONLY</p>																					
	<table border="1" style="width: 100%; border-collapse: collapse;"> <thead> <tr style="background-color: #cccccc;"> <th colspan="2" style="text-align: center;">SYSTEM PROPERTIES</th> </tr> </thead> <tbody> <tr> <th colspan="2" style="text-align: center;">Moment of Inertia, Section Modulus & Area</th> </tr> <tr> <td style="text-align: right;">Moment of Inertia, I_{yy}</td> <td>I_{yy} = 0.90 in⁴</td> </tr> <tr> <td style="text-align: right;">Section Modulus, S_{yy}</td> <td>S_{yy} = 0.89 in³</td> </tr> <tr> <td style="text-align: right;">Total Area</td> <td>A = 1.60 in²</td> </tr> <tr> <th colspan="2" style="text-align: center;">Modulus of Elasticity</th> </tr> <tr> <td style="text-align: right;">Aluminum</td> <td>10,000,000 PSI</td> </tr> <tr> <td style="text-align: right;">Steel</td> <td>29,000,000 PSI</td> </tr> <tr style="background-color: #cccccc;"> <th colspan="2" style="text-align: center;">GENERAL NOTES</th> </tr> <tr> <td colspan="2"> <ol style="list-style-type: none"> 1. Deflection Limit: 0.125" (3.2mm). 2. Charts are calculated assuming a 1-15/16" overall sealed unit (6mm/18mm spacer/6mm/13mm spacer/6mm). 3. Calculations are based on the position of the setting blocks being placed at 1/4 or 1/8 points. </td> </tr> </tbody> </table>	SYSTEM PROPERTIES		Moment of Inertia, Section Modulus & Area		Moment of Inertia, I _{yy}	I _{yy} = 0.90 in ⁴	Section Modulus, S _{yy}	S _{yy} = 0.89 in ³	Total Area	A = 1.60 in ²	Modulus of Elasticity		Aluminum	10,000,000 PSI	Steel	29,000,000 PSI	GENERAL NOTES		<ol style="list-style-type: none"> 1. Deflection Limit: 0.125" (3.2mm). 2. Charts are calculated assuming a 1-15/16" overall sealed unit (6mm/18mm spacer/6mm/13mm spacer/6mm). 3. Calculations are based on the position of the setting blocks being placed at 1/4 or 1/8 points. 	
SYSTEM PROPERTIES																					
Moment of Inertia, Section Modulus & Area																					
Moment of Inertia, I _{yy}	I _{yy} = 0.90 in ⁴																				
Section Modulus, S _{yy}	S _{yy} = 0.89 in ³																				
Total Area	A = 1.60 in ²																				
Modulus of Elasticity																					
Aluminum	10,000,000 PSI																				
Steel	29,000,000 PSI																				
GENERAL NOTES																					
<ol style="list-style-type: none"> 1. Deflection Limit: 0.125" (3.2mm). 2. Charts are calculated assuming a 1-15/16" overall sealed unit (6mm/18mm spacer/6mm/13mm spacer/6mm). 3. Calculations are based on the position of the setting blocks being placed at 1/4 or 1/8 points. 																					



**METRO
ALUMINUM**

Products Ltd.

2500 SERIES

CURTAIN WALL & WINDOW SYSTEM
2 1/2" (63.5 mm) - FRAME

D

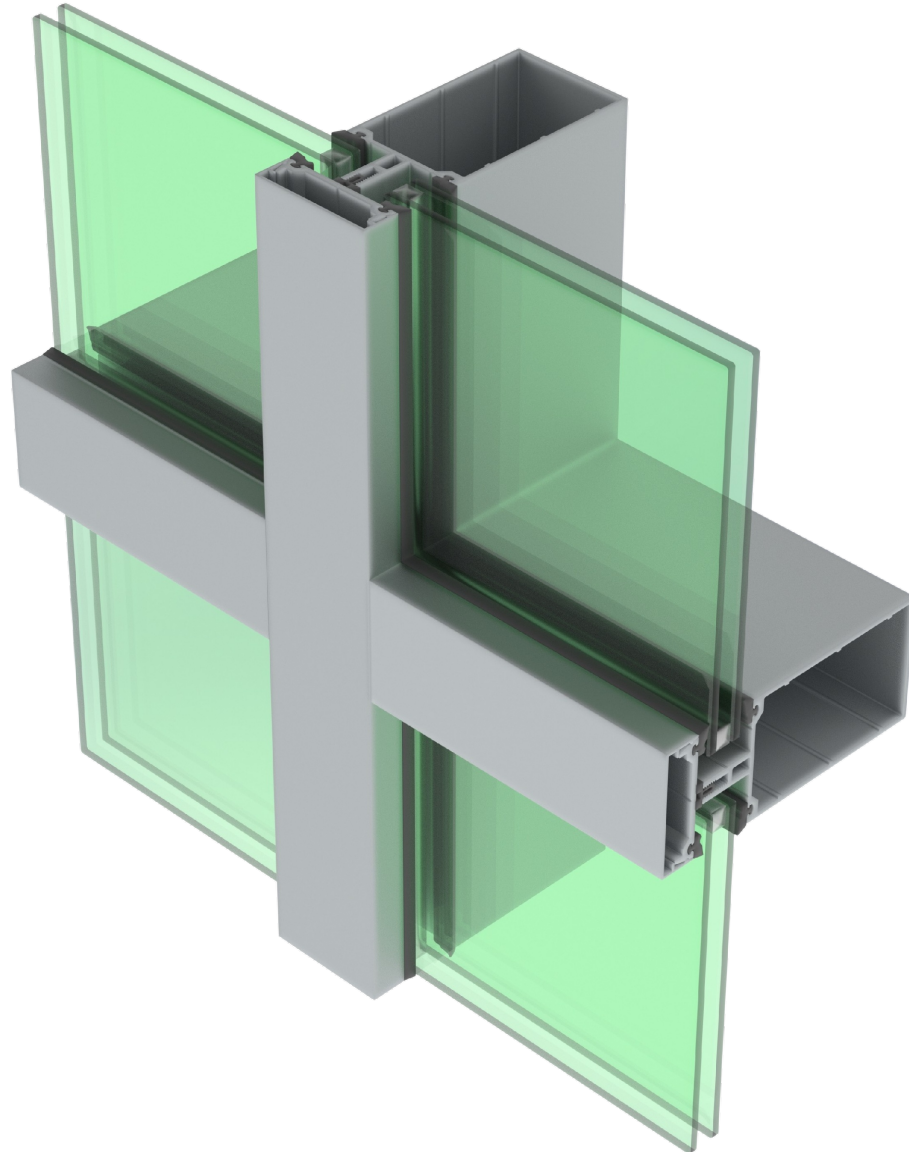



**METRO
ALUMINUM**
Products Ltd.

2500 SERIES

CURTAIN WALL & WINDOW SYSTEM
2 1/2" (63.5 mm) - FRAME

**D
35**

PICTORIAL (3D) PRESENTATION

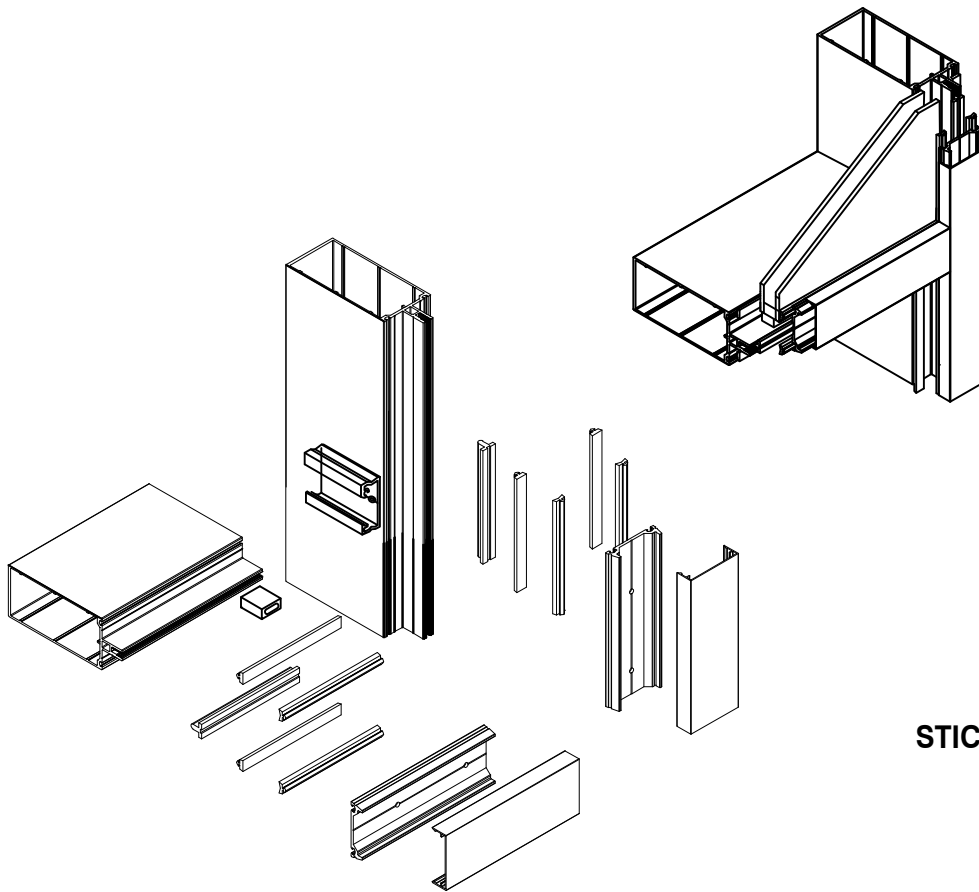

STICK SYSTEM FRAMING



**METRO
ALUMINUM**
Products Ltd.

2500 SERIES

CURTAIN WALL & WINDOW SYSTEM
2 1/2" (63.5 mm) - FRAME

**D
36**

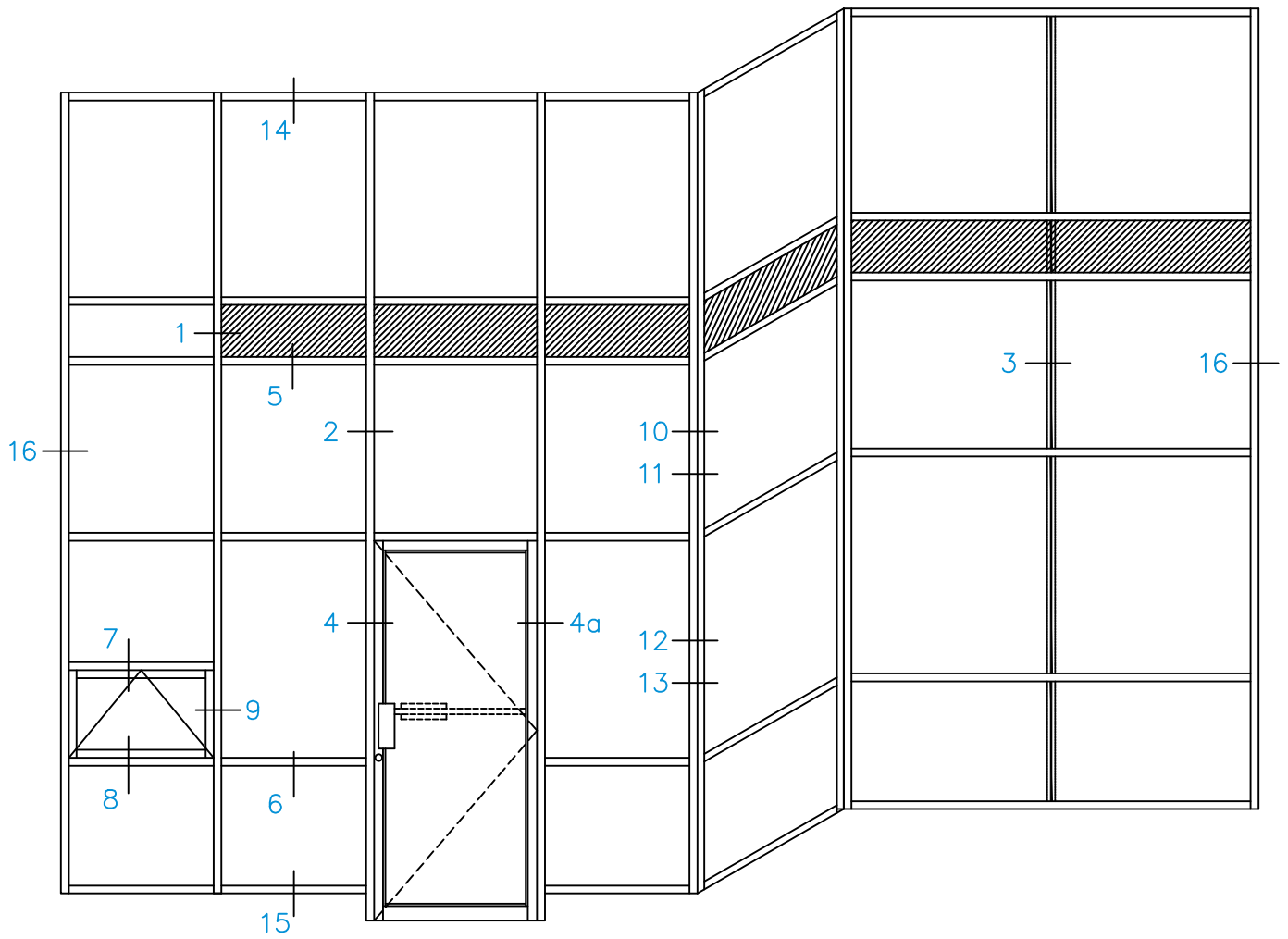

ELEVATION



BACK SECTIONS

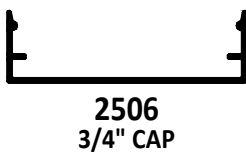
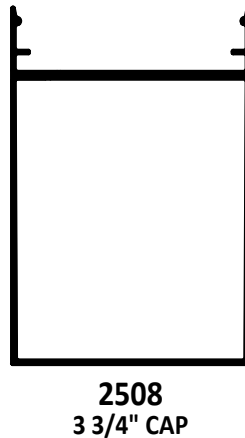
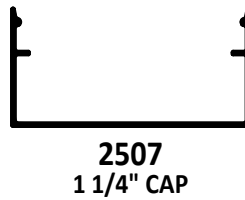
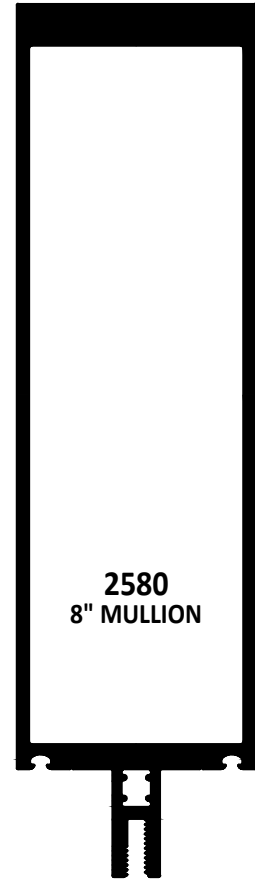
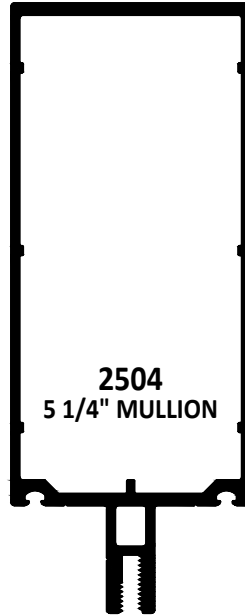
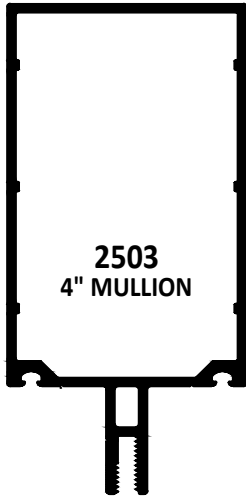



SSG COMPONENTS

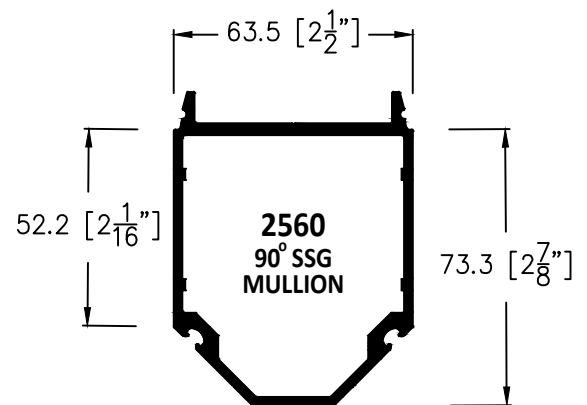
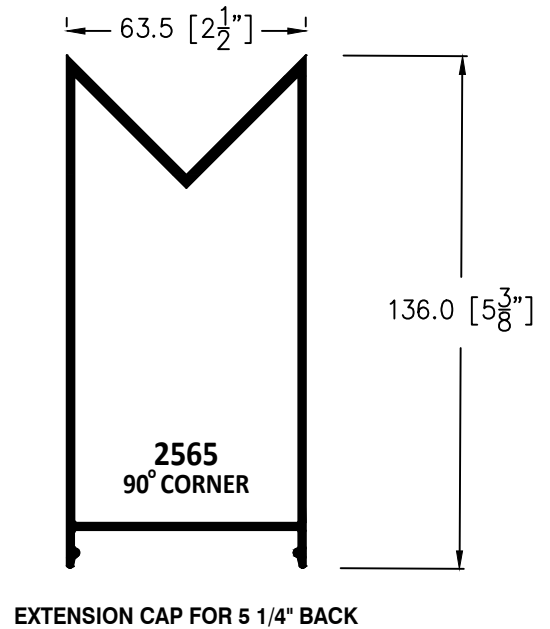
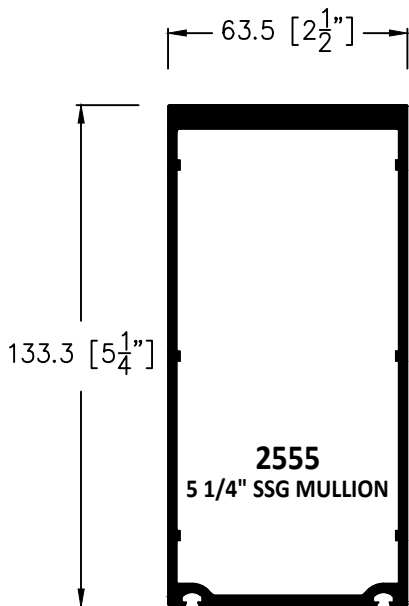
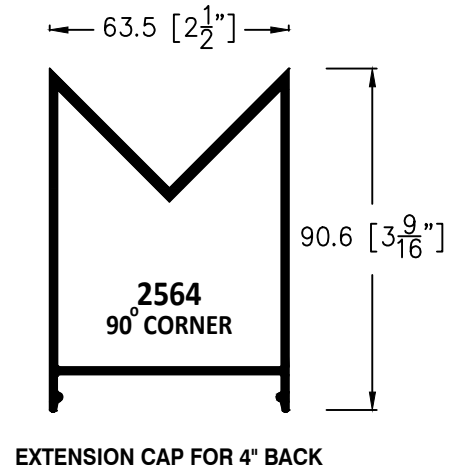
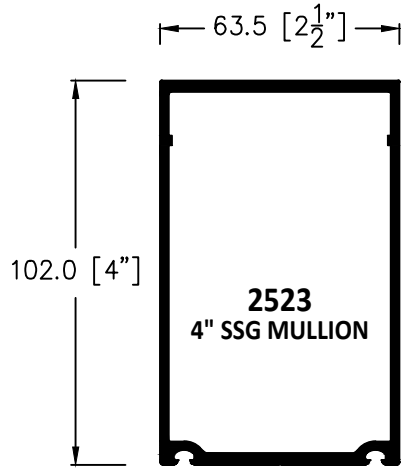



MISC. COMPONENTS



2410
THERMAL BREAK



2515
CORNER BLOCK



2460
SPONGE GASKET
(INTERIOR)



2450
DENSE GASKET
(EXTERIOR)

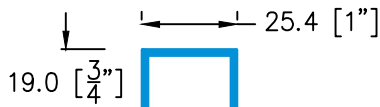

7501 PVC
ANTI-ROTATION

2435
DOOR
ADAPTER

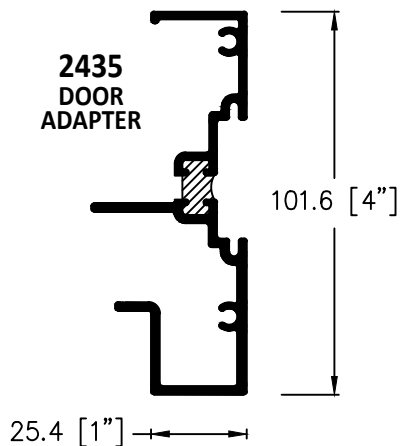

2520
SPIGOT

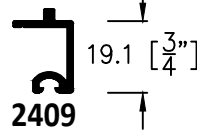

2409
SINGLE GLASS
ADAPTOR

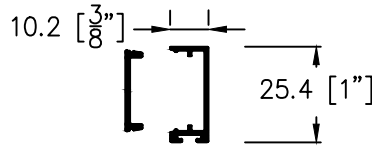

2417/2418
SURFACE APPLIED
DOOR STOP



2430
BACK-PAN
ADAPTOR

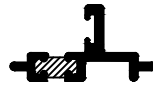

20120T
DOOR STOP
FOR 2" DOORS



2012T
DOOR STOP
FOR 1 3/4" DOORS

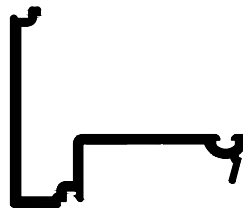

2517
FLUSH DOOR
ADAPTOR



5102
1" X 2" PERIMETER ANGLE



2518
FLUSH DOOR
ADAPTOR CAP



5103
1" X 3" PERIMETER ANGLE

TYPICAL DETAILS

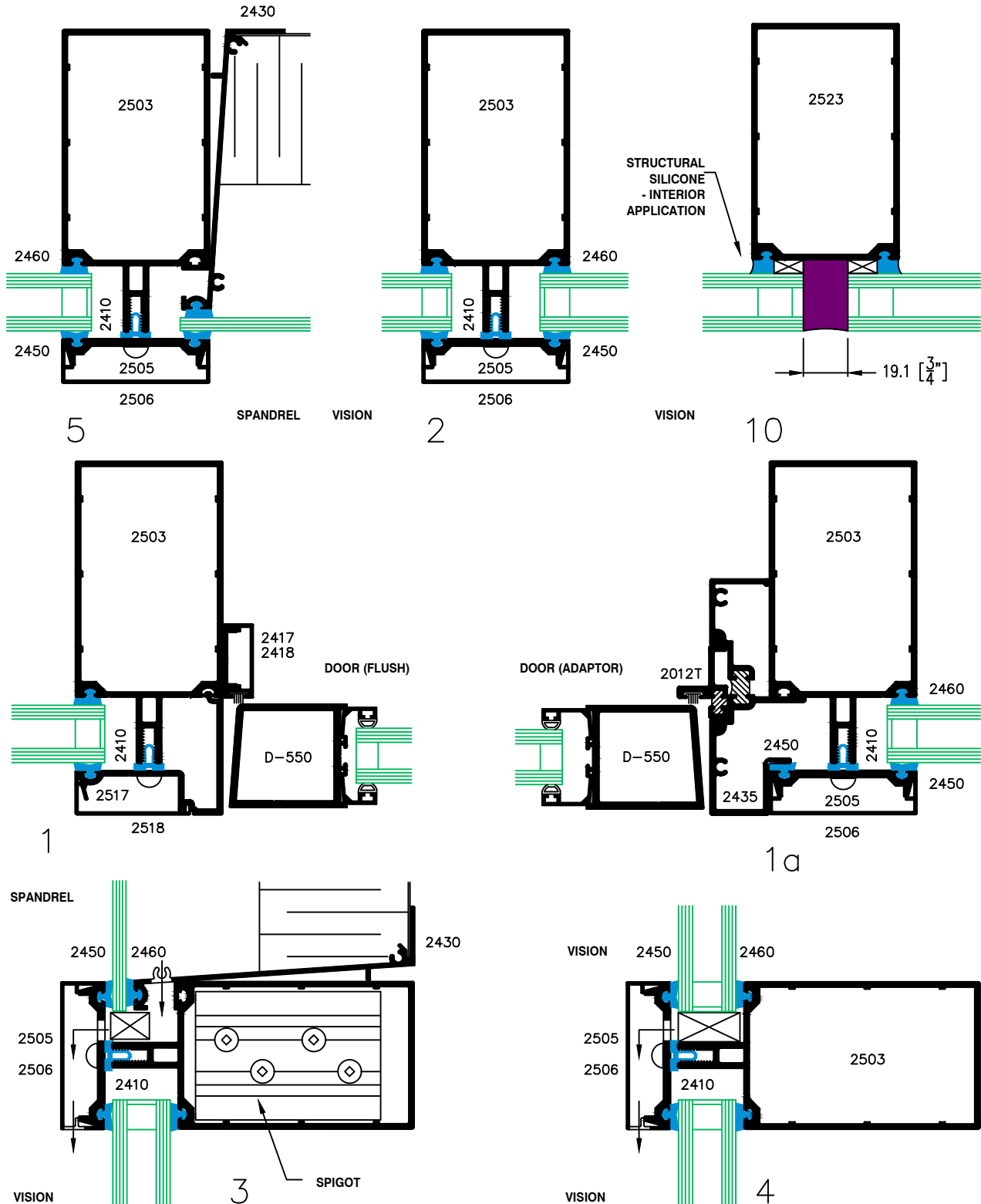

TYPICAL CURTAIN WALL VENT DETAILS

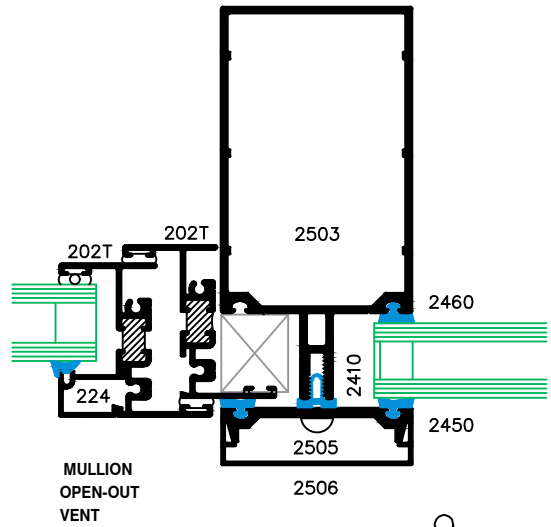
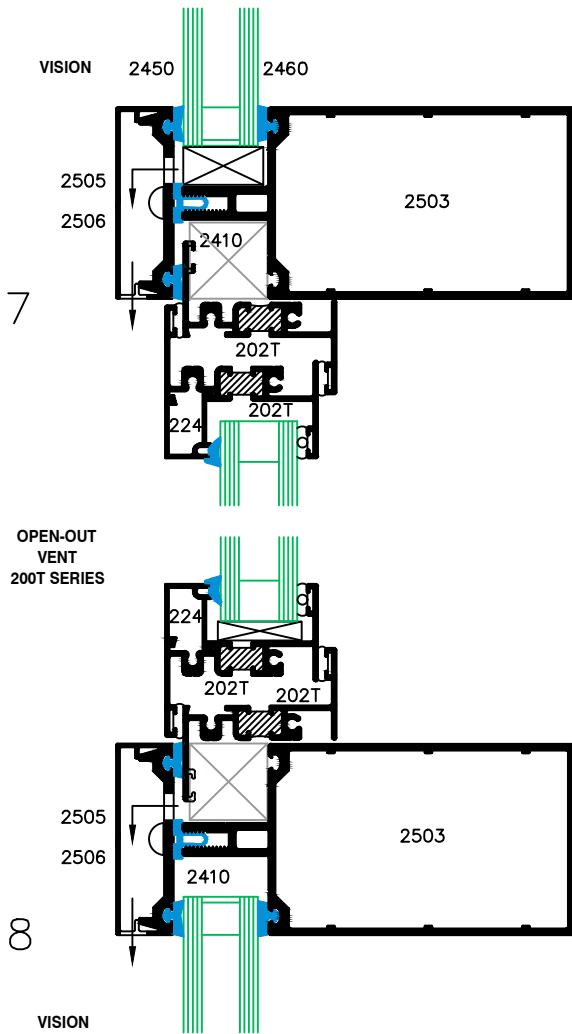

TYPICAL CAPTURED CORNER DETAILS

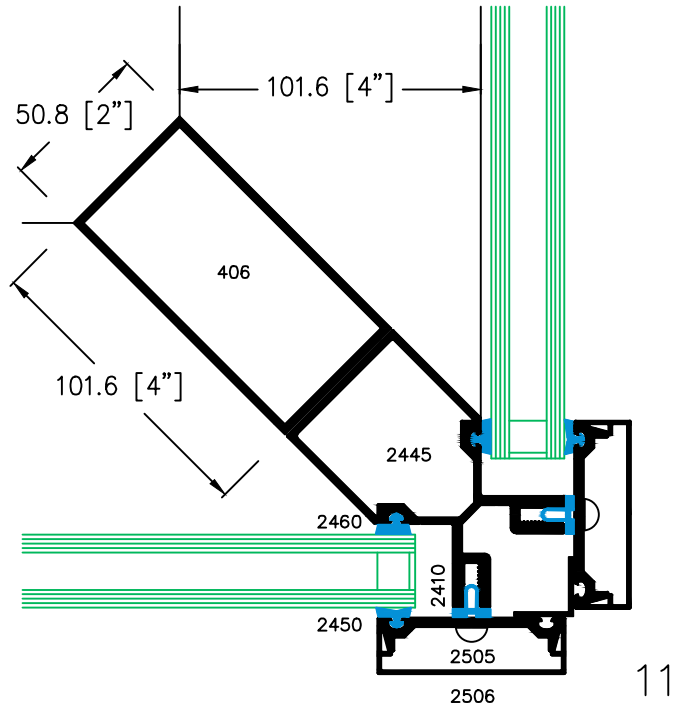

90° CAPTURED CORNER

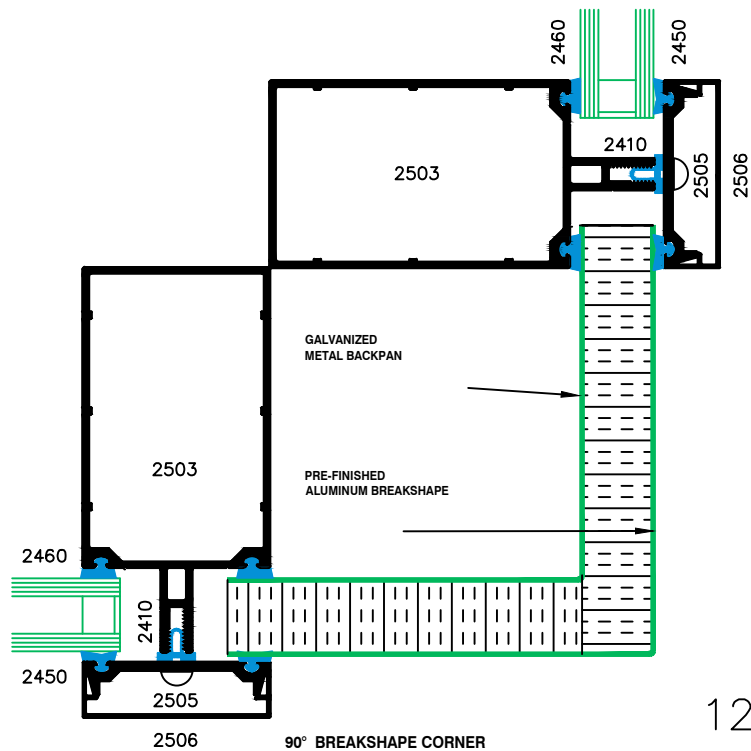

90° BREAKSHAPE CORNER

TYPICAL BUTT-JOINT CORNER DETAILS

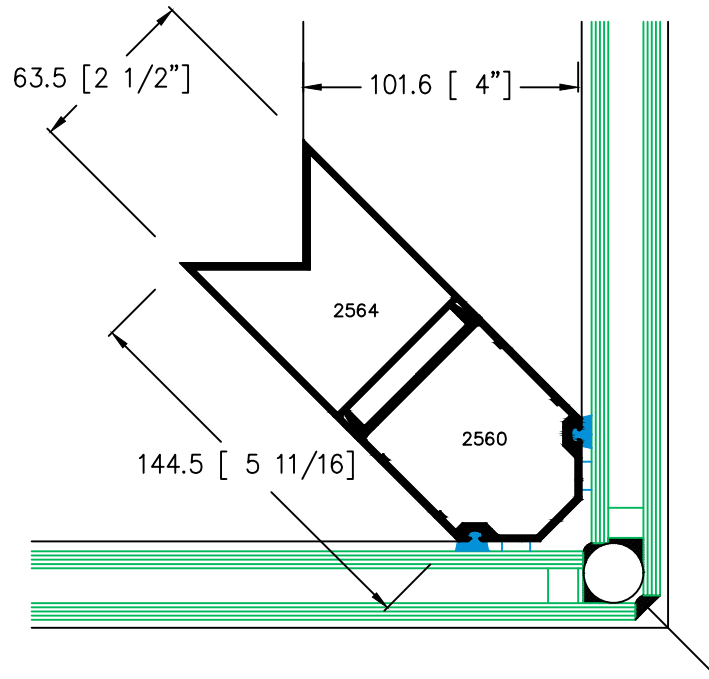

90° BUTT-JOINT CORNER
AT 4" BACK MEMBER

12

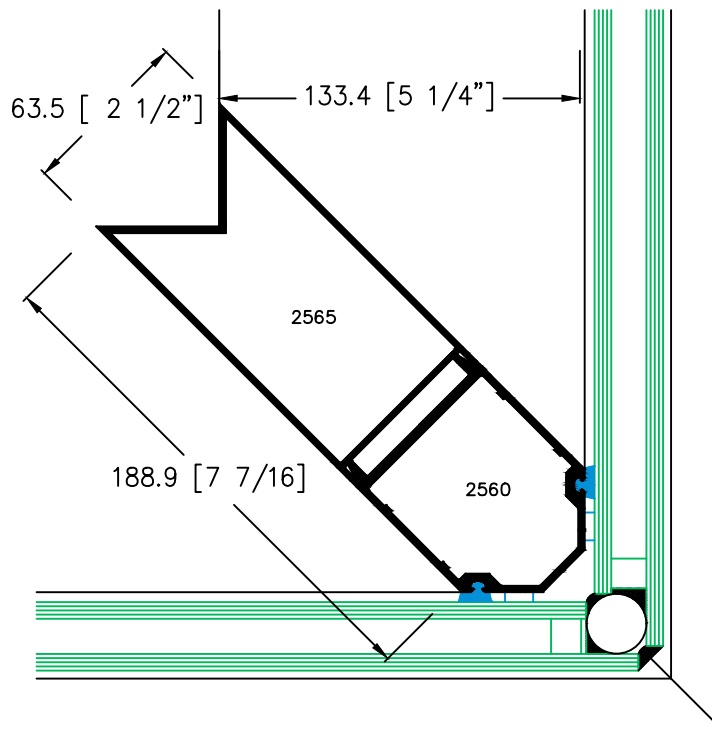

90° BUTT-JOINT CORNER
AT 5 1/4" BACK MEMBER

13

ALTERNATE DOOR DETAILS

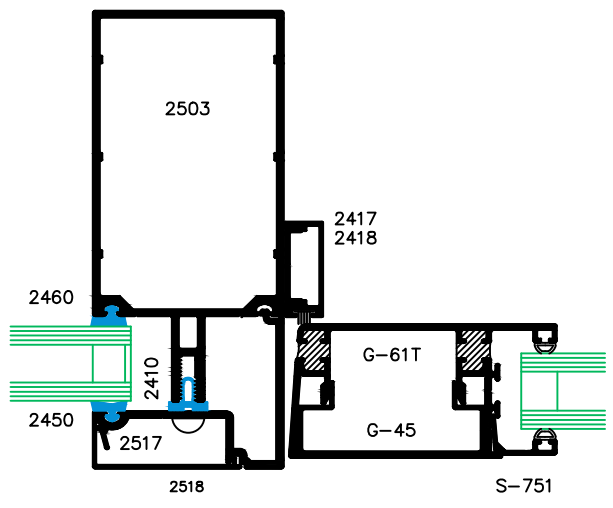

GLACIER DOOR

15

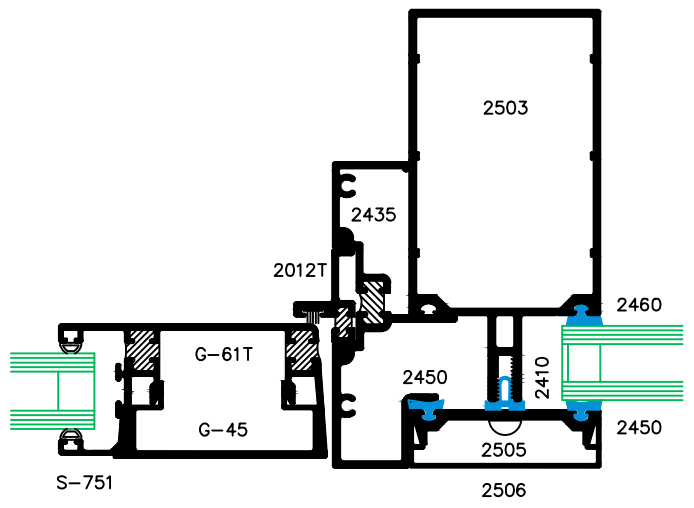

SWING DOORS

15a

GLACIER DOOR

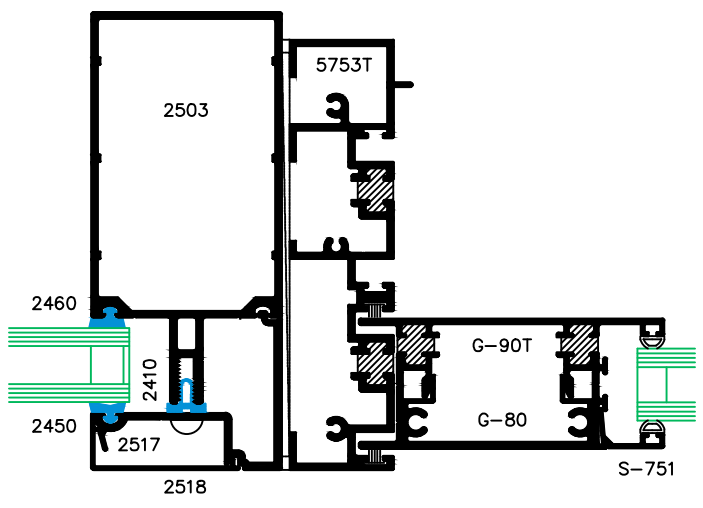

1100T JAMB AT SLIDER

16

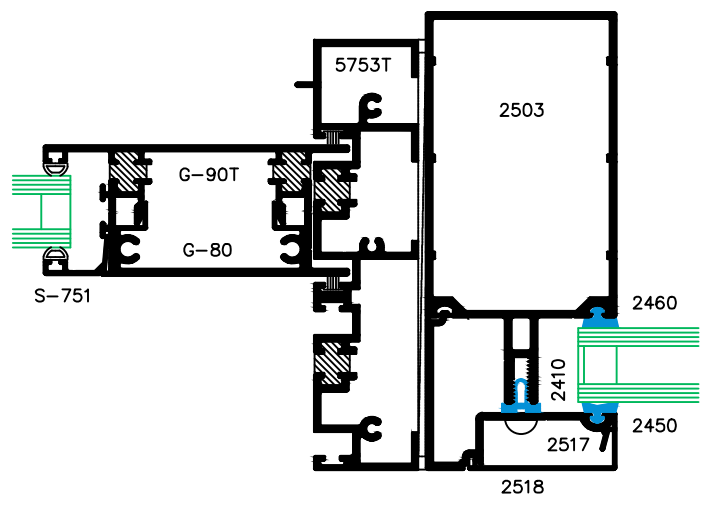

SLIDING DOORS

16a

1100T JAMB AT FIXED PANEL



**INTERFACE DETAILS
(SUGGESTED ONLY)**

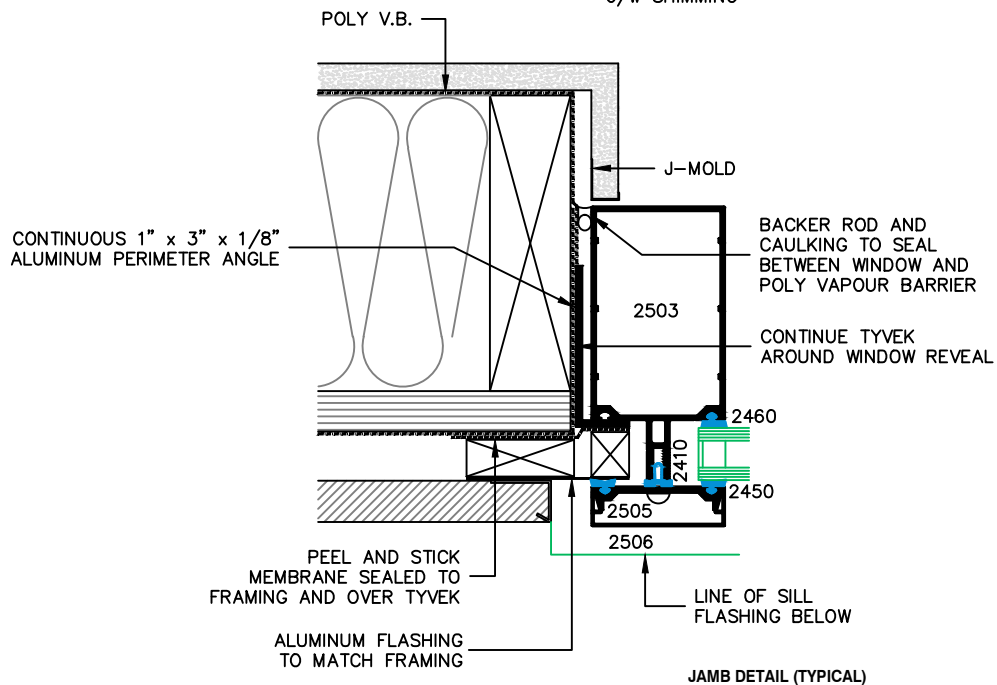
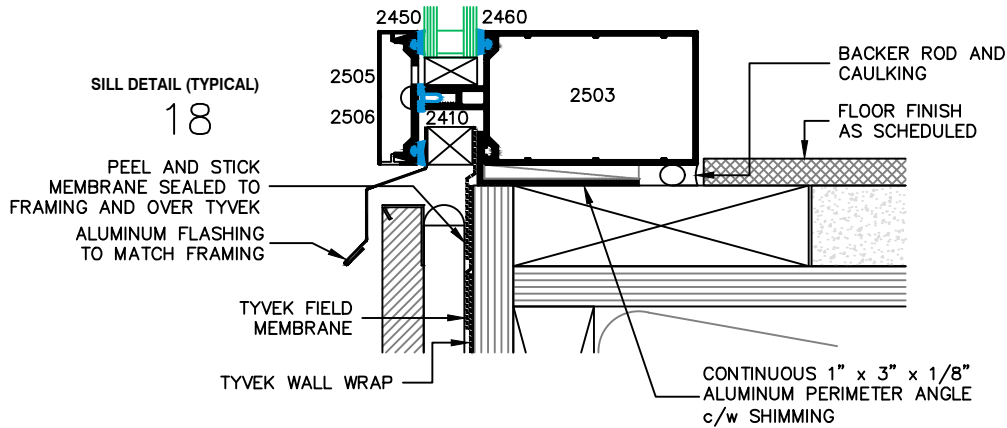
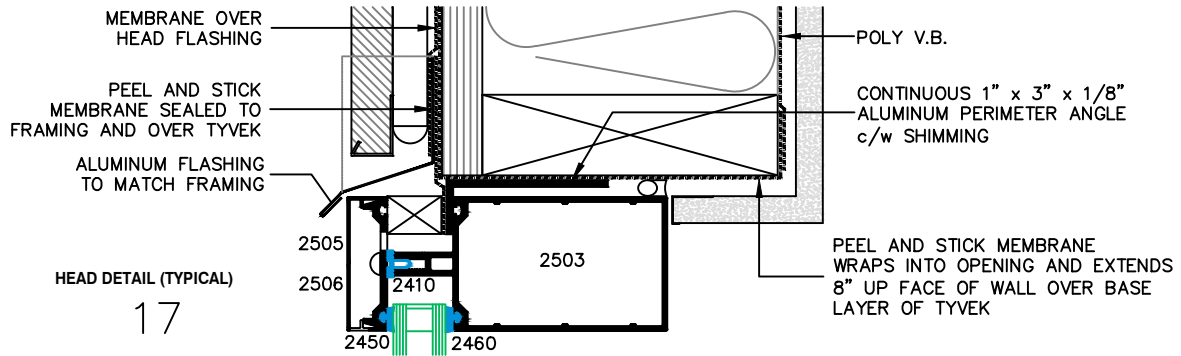

TYPICAL ANCHORING DETAILS

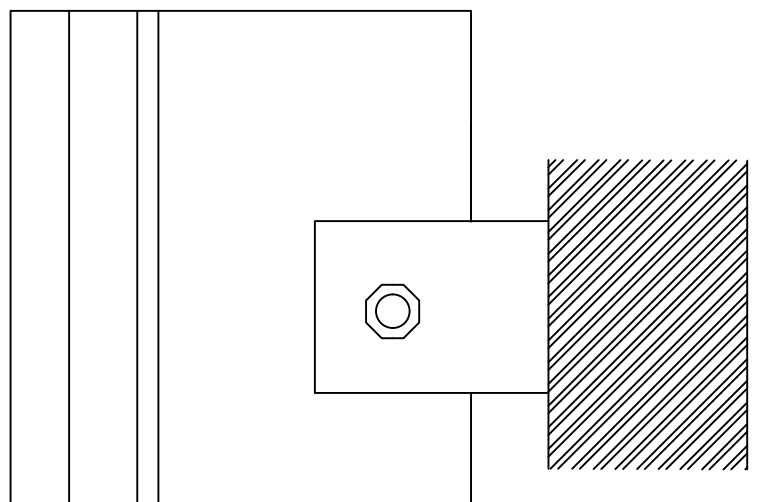
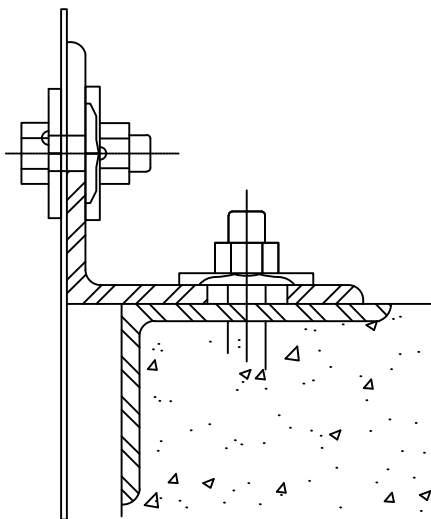
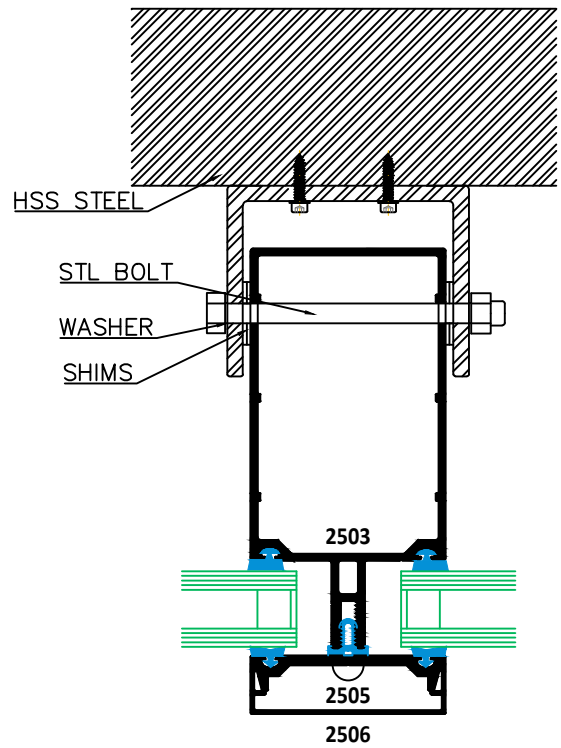
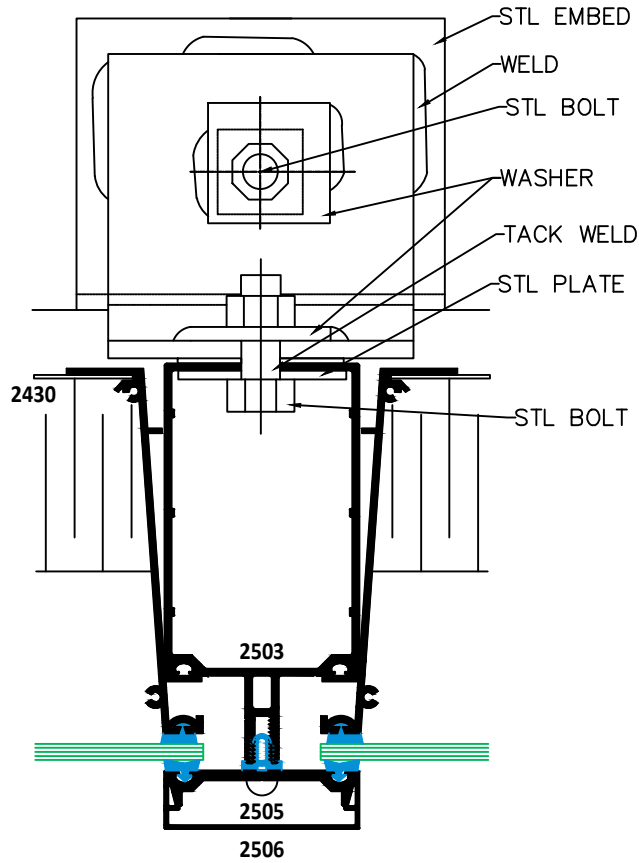

SECTION DETAILS

EXPANSION & SPLICE DETAILS

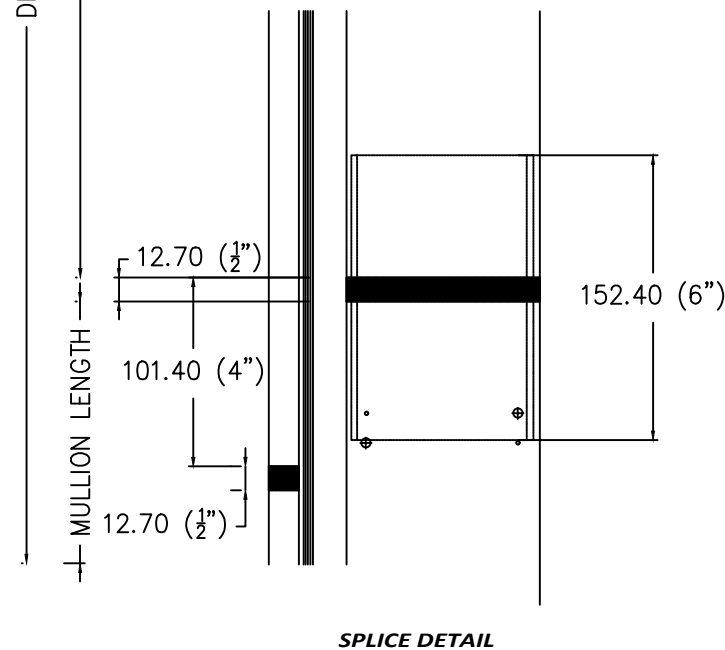
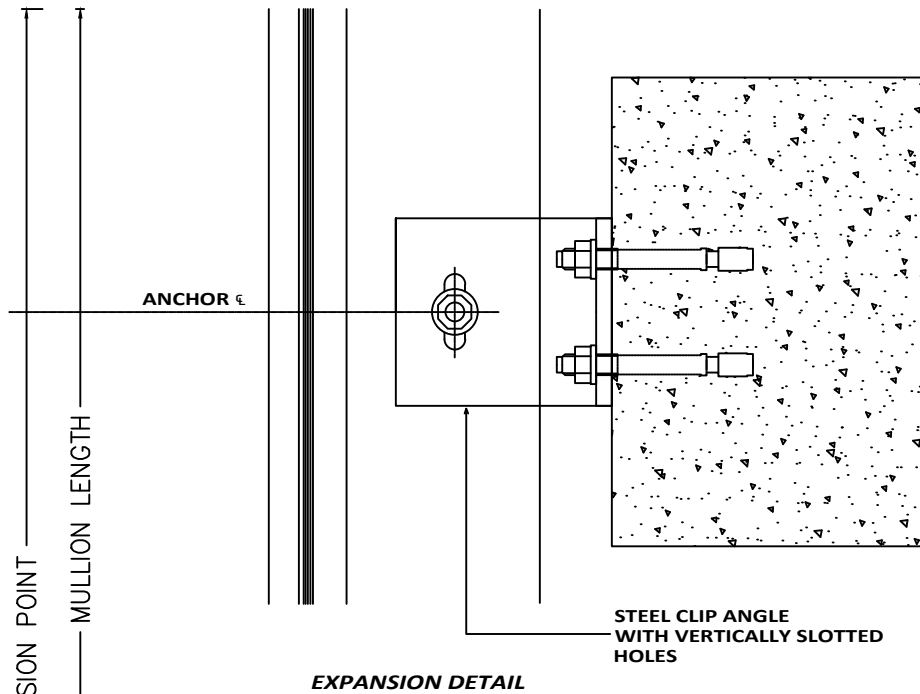

WIND LOAD CHART FOR 2 1/2" x 4" MULLION - PART # 2503

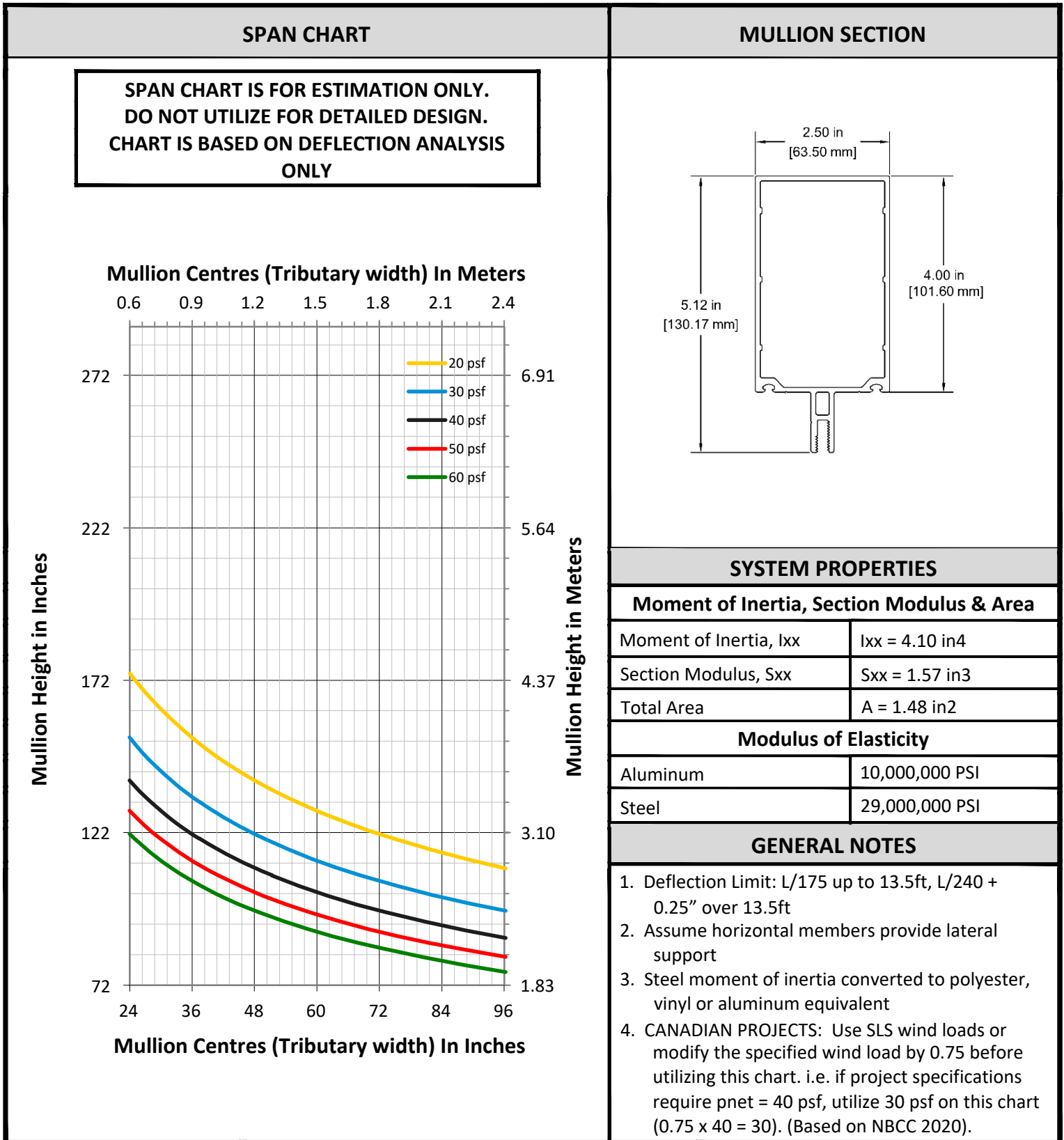

STEEL LOADED WIND LOAD CHART FOR 2 1/2" x 4" MULLION - PART # 2503

SPAN CHART

MULLION SECTION

**SPAN CHART IS FOR ESTIMATION ONLY.
DO NOT UTILIZE FOR DETAILED DESIGN.
CHART IS BASED ON DEFLECTION ANALYSIS
ONLY**

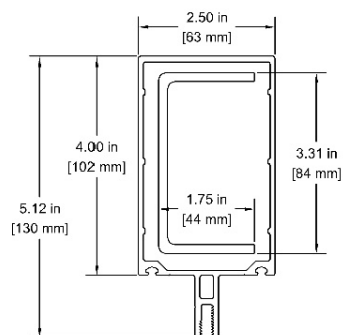

Mullion Centres (Tributary width) In Meters

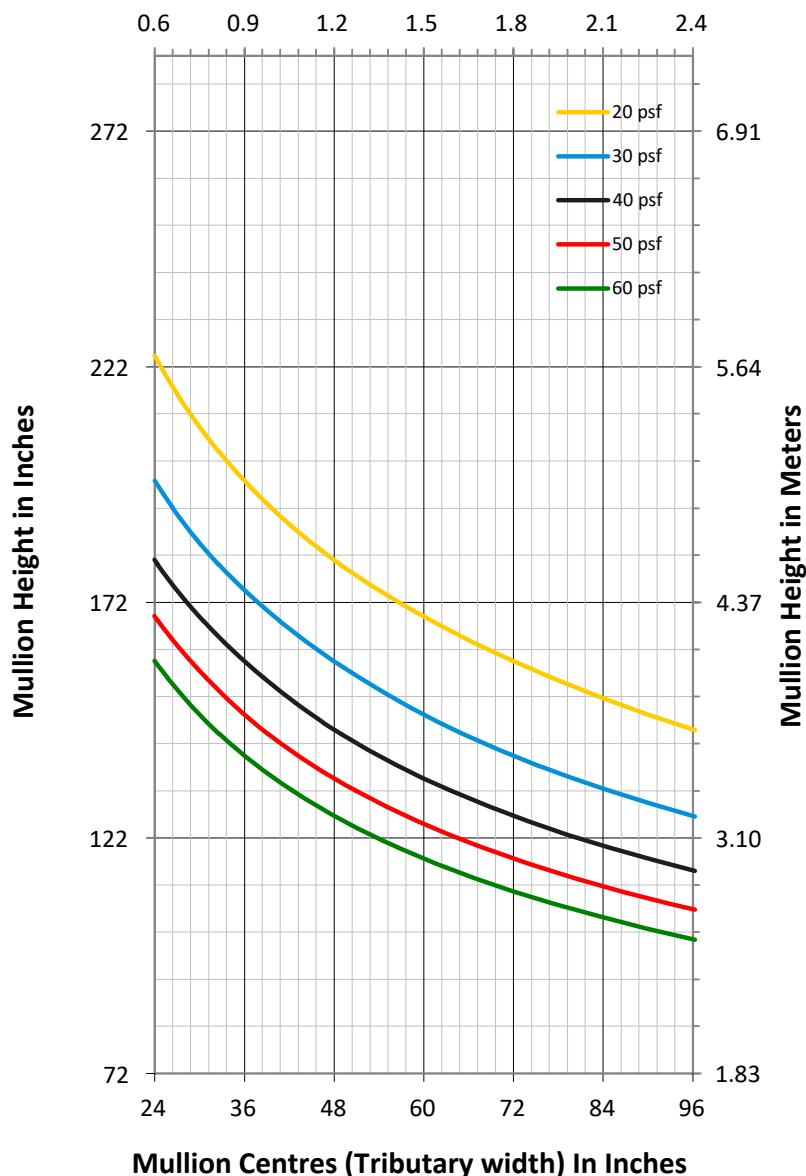

SYSTEM PROPERTIES

Moment of Inertia, Section Modulus & Area

Moment of Inertia, Ixx	Ixx = 9.26 in ⁴
Section Modulus, Sxx	Sxx = 3.20 in ³
Total Area	A = 1.48 in ²

Modulus of Elasticity

Aluminum	10,000,000 PSI
Steel	29,000,000 PSI

GENERAL NOTES

1. Deflection Limit: L/175 up to 13.5ft, L/240 + 0.25" over 13.5ft
2. Assume horizontal members provide lateral support
3. Steel moment of inertia converted to polyester, vinyl or aluminum equivalent
4. CANADIAN PROJECTS: Use SLS wind loads or modify the specified wind load by 0.75 before utilizing this chart. i.e. if project specifications require pnet = 40 psf, utilize 30 psf on this chart (0.75 x 40 = 30). (Based on NBCC 2020).

DEAD LOAD CHART FOR 2 1/2" x 4" MULLION - PART # 2503

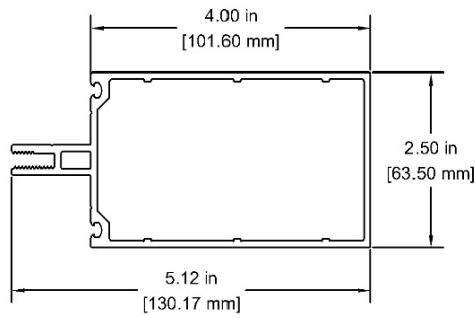
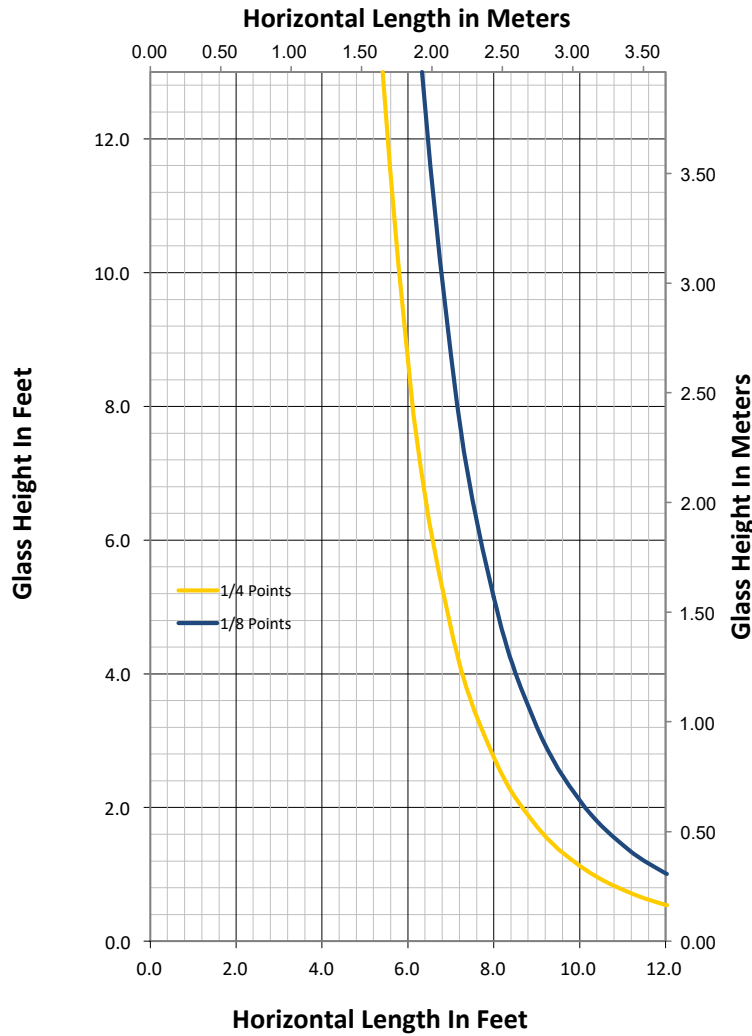
SPAN CHART	MULLION SECTION																				
<p>SPAN CHART IS FOR ESTIMATION ONLY. DO NOT UTILIZE FOR DETAILED DESIGN. CHART IS BASED ON DEFLECTION ANALYSIS ONLY</p>																					
	<table border="1" style="width: 100%; border-collapse: collapse;"> <thead> <tr style="background-color: #cccccc;"> <th colspan="2" style="text-align: center;">SYSTEM PROPERTIES</th> </tr> </thead> <tbody> <tr style="background-color: #cccccc;"> <th colspan="2" style="text-align: center;">Moment of Inertia, Section Modulus & Area</th> </tr> <tr> <td style="text-align: left;">Moment of Inertia, I_{yy}</td> <td>I_{yy} = 1.34 in⁴</td> </tr> <tr> <td style="text-align: left;">Section Modulus, S_{yy}</td> <td>S_{yy} = 1.07 in³</td> </tr> <tr> <td style="text-align: left;">Total Area</td> <td>A = 1.48 in²</td> </tr> <tr style="background-color: #cccccc;"> <th colspan="2" style="text-align: center;">Modulus of Elasticity</th> </tr> <tr> <td style="text-align: left;">Aluminum</td> <td>10,000,000 PSI</td> </tr> <tr> <td style="text-align: left;">Steel</td> <td>29,000,000 PSI</td> </tr> <tr style="background-color: #cccccc;"> <th colspan="2" style="text-align: center;">GENERAL NOTES</th> </tr> <tr> <td colspan="2"> <ol style="list-style-type: none"> 1. Deflection Limit: 0.125" (3.2mm). 2. Charts are calculated assuming a 1" overall sealed unit (6mm/13mm spacer/6mm) 3. Calculations are based on the position of the setting blocks being placed at 1/4 or 1/8 points. </td> </tr> </tbody> </table>	SYSTEM PROPERTIES		Moment of Inertia, Section Modulus & Area		Moment of Inertia, I _{yy}	I _{yy} = 1.34 in ⁴	Section Modulus, S _{yy}	S _{yy} = 1.07 in ³	Total Area	A = 1.48 in ²	Modulus of Elasticity		Aluminum	10,000,000 PSI	Steel	29,000,000 PSI	GENERAL NOTES		<ol style="list-style-type: none"> 1. Deflection Limit: 0.125" (3.2mm). 2. Charts are calculated assuming a 1" overall sealed unit (6mm/13mm spacer/6mm) 3. Calculations are based on the position of the setting blocks being placed at 1/4 or 1/8 points. 	
SYSTEM PROPERTIES																					
Moment of Inertia, Section Modulus & Area																					
Moment of Inertia, I _{yy}	I _{yy} = 1.34 in ⁴																				
Section Modulus, S _{yy}	S _{yy} = 1.07 in ³																				
Total Area	A = 1.48 in ²																				
Modulus of Elasticity																					
Aluminum	10,000,000 PSI																				
Steel	29,000,000 PSI																				
GENERAL NOTES																					
<ol style="list-style-type: none"> 1. Deflection Limit: 0.125" (3.2mm). 2. Charts are calculated assuming a 1" overall sealed unit (6mm/13mm spacer/6mm) 3. Calculations are based on the position of the setting blocks being placed at 1/4 or 1/8 points. 																					

WIND LOAD CHART FOR 2 1/2" x 4" SSG MULLION - PART # 2523

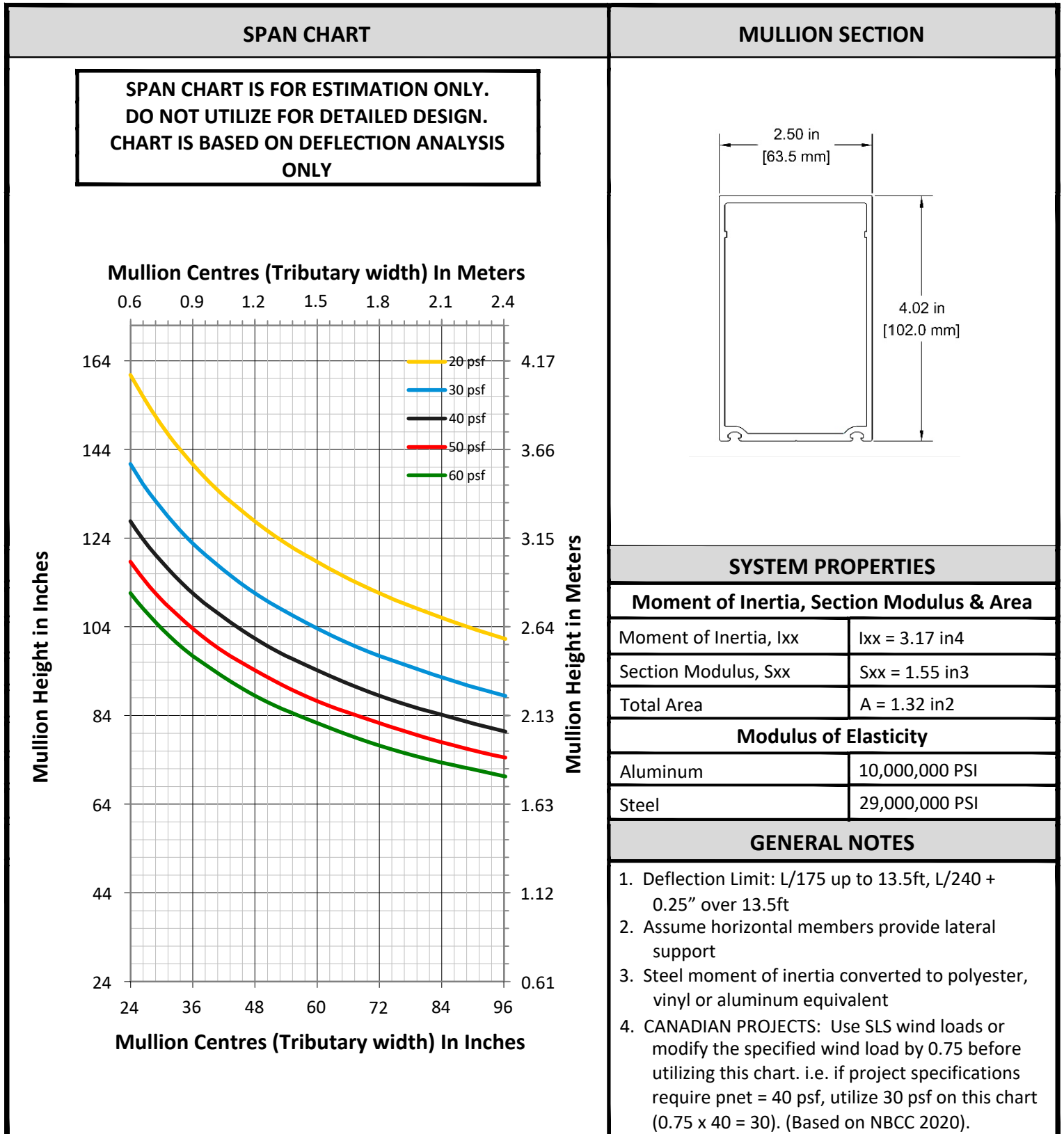

STEEL LOADED WIND LOAD CHART FOR 2 1/2" x 4" SSG MULLION - PART # 2523

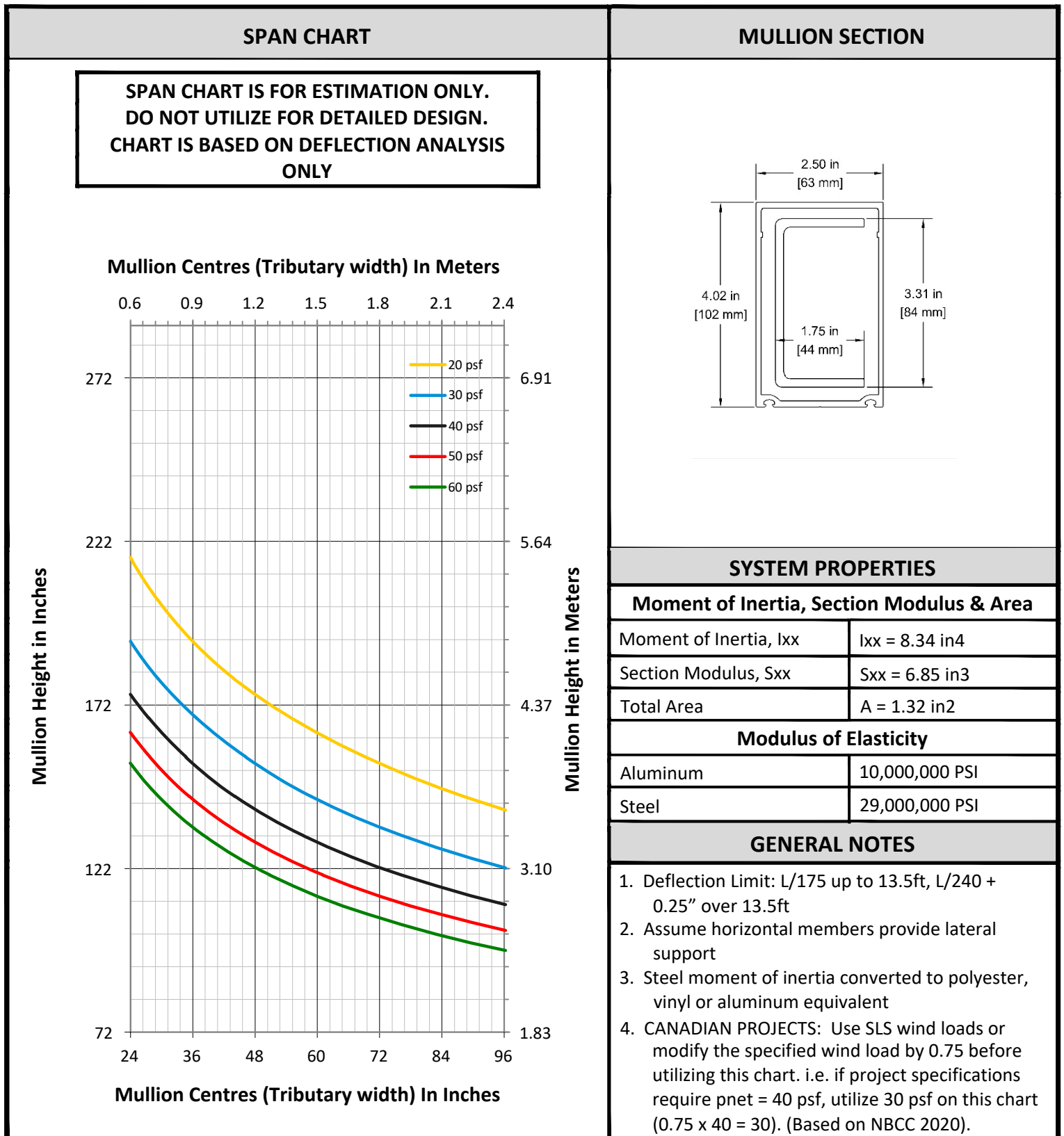

DEAD LOAD CHART FOR 2 1/2" x 4" SSG MULLION - PART # 2523

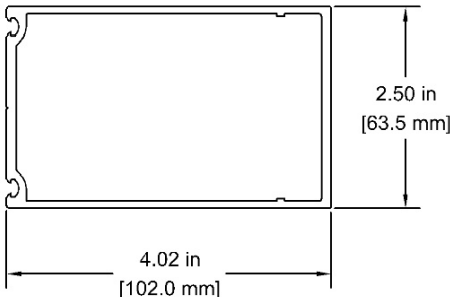
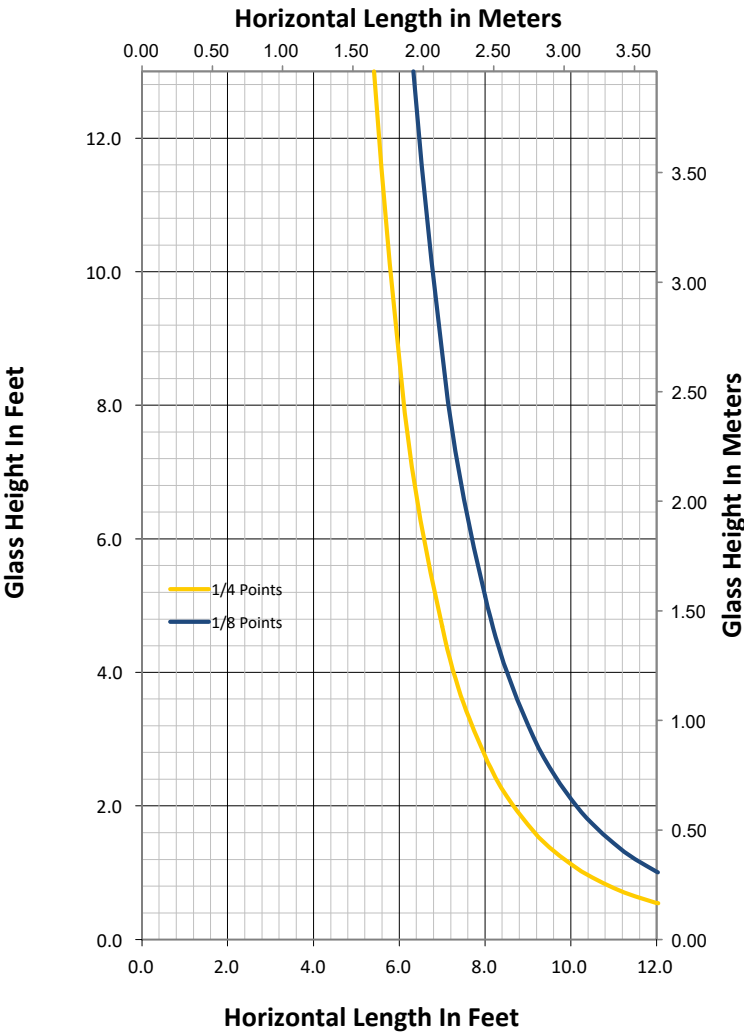
SPAN CHART	MULLION SECTION																				
<p>SPAN CHART IS FOR ESTIMATION ONLY. DO NOT UTILIZE FOR DETAILED DESIGN. CHART IS BASED ON DEFLECTION ANALYSIS ONLY</p>																					
	<table border="1" style="width: 100%; border-collapse: collapse;"> <thead> <tr style="background-color: #cccccc;"> <th colspan="2" style="text-align: center;">SYSTEM PROPERTIES</th> </tr> </thead> <tbody> <tr style="background-color: #cccccc;"> <th colspan="2" style="text-align: center;">Moment of Inertia, Section Modulus & Area</th> </tr> <tr> <td style="text-align: left;">Moment of Inertia, I_{yy}</td> <td style="text-align: right;">$I_{yy} = 1.34 \text{ in}^4$</td> </tr> <tr> <td style="text-align: left;">Section Modulus, S_{yy}</td> <td style="text-align: right;">$S_{yy} = 1.07 \text{ in}^3$</td> </tr> <tr> <td style="text-align: left;">Total Area</td> <td style="text-align: right;">$A = 1.32 \text{ in}^2$</td> </tr> <tr style="background-color: #cccccc;"> <th colspan="2" style="text-align: center;">Modulus of Elasticity</th> </tr> <tr> <td style="text-align: left;">Aluminum</td> <td style="text-align: right;">10,000,000 PSI</td> </tr> <tr> <td style="text-align: left;">Steel</td> <td style="text-align: right;">29,000,000 PSI</td> </tr> <tr style="background-color: #cccccc;"> <th colspan="2" style="text-align: center;">GENERAL NOTES</th> </tr> <tr> <td colspan="2"> <ol style="list-style-type: none"> 1. Deflection Limit: 0.125" (3.2mm). 2. Charts are calculated assuming a 1" overall sealed unit (6mm/13mm spacer/6mm) 3. Calculations are based on the position of the setting blocks being placed at 1/4 or 1/8 points. </td> </tr> </tbody> </table>	SYSTEM PROPERTIES		Moment of Inertia, Section Modulus & Area		Moment of Inertia, I_{yy}	$I_{yy} = 1.34 \text{ in}^4$	Section Modulus, S_{yy}	$S_{yy} = 1.07 \text{ in}^3$	Total Area	$A = 1.32 \text{ in}^2$	Modulus of Elasticity		Aluminum	10,000,000 PSI	Steel	29,000,000 PSI	GENERAL NOTES		<ol style="list-style-type: none"> 1. Deflection Limit: 0.125" (3.2mm). 2. Charts are calculated assuming a 1" overall sealed unit (6mm/13mm spacer/6mm) 3. Calculations are based on the position of the setting blocks being placed at 1/4 or 1/8 points. 	
SYSTEM PROPERTIES																					
Moment of Inertia, Section Modulus & Area																					
Moment of Inertia, I_{yy}	$I_{yy} = 1.34 \text{ in}^4$																				
Section Modulus, S_{yy}	$S_{yy} = 1.07 \text{ in}^3$																				
Total Area	$A = 1.32 \text{ in}^2$																				
Modulus of Elasticity																					
Aluminum	10,000,000 PSI																				
Steel	29,000,000 PSI																				
GENERAL NOTES																					
<ol style="list-style-type: none"> 1. Deflection Limit: 0.125" (3.2mm). 2. Charts are calculated assuming a 1" overall sealed unit (6mm/13mm spacer/6mm) 3. Calculations are based on the position of the setting blocks being placed at 1/4 or 1/8 points. 																					

WIND LOAD CHART FOR 2 1/2" x 5 1/4" MULLION - PART # 2504

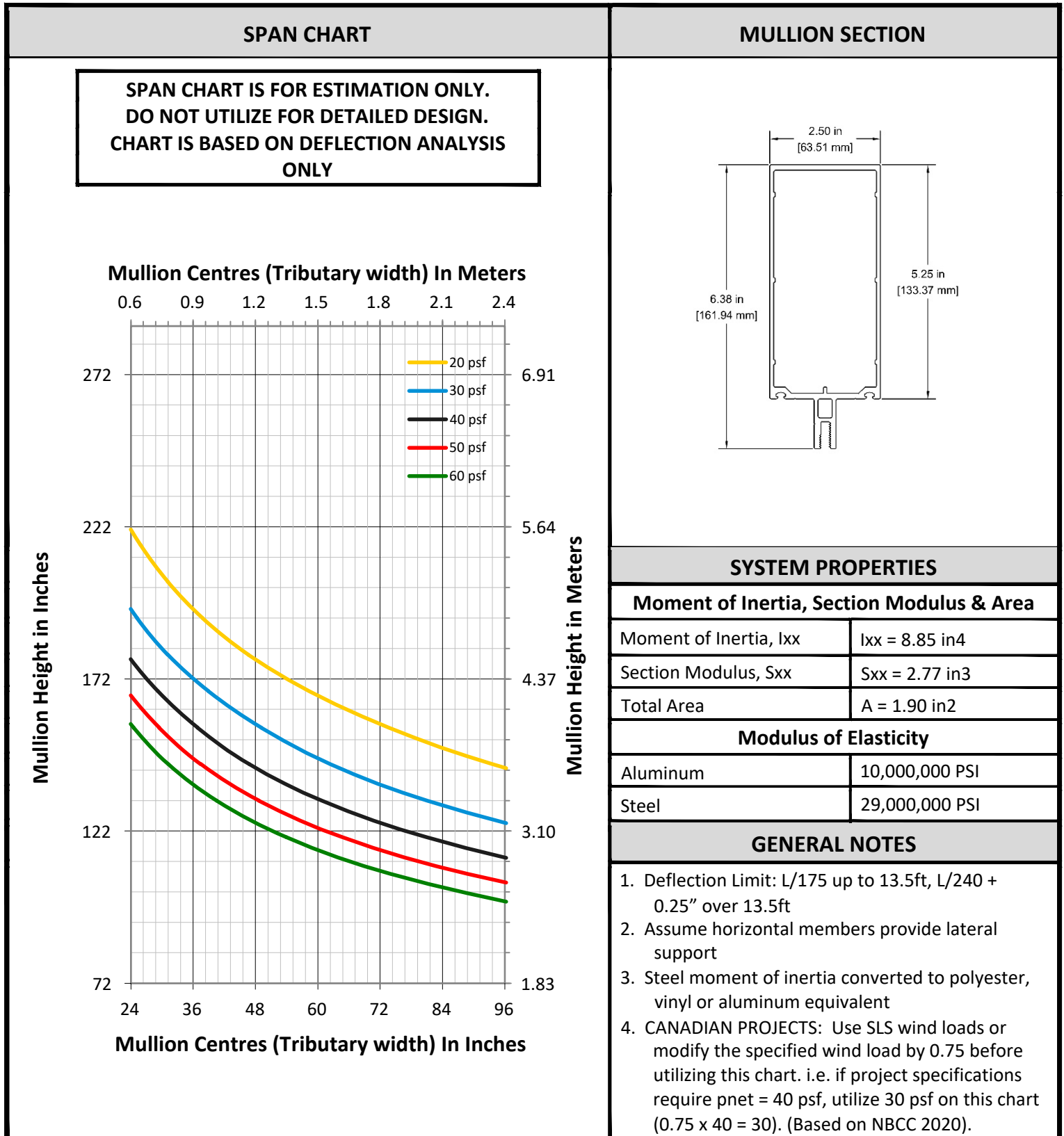

STEEL LOADED WIND LOAD CHART FOR 2 1/2" x 5 1/4" MULLION - PART # 2504

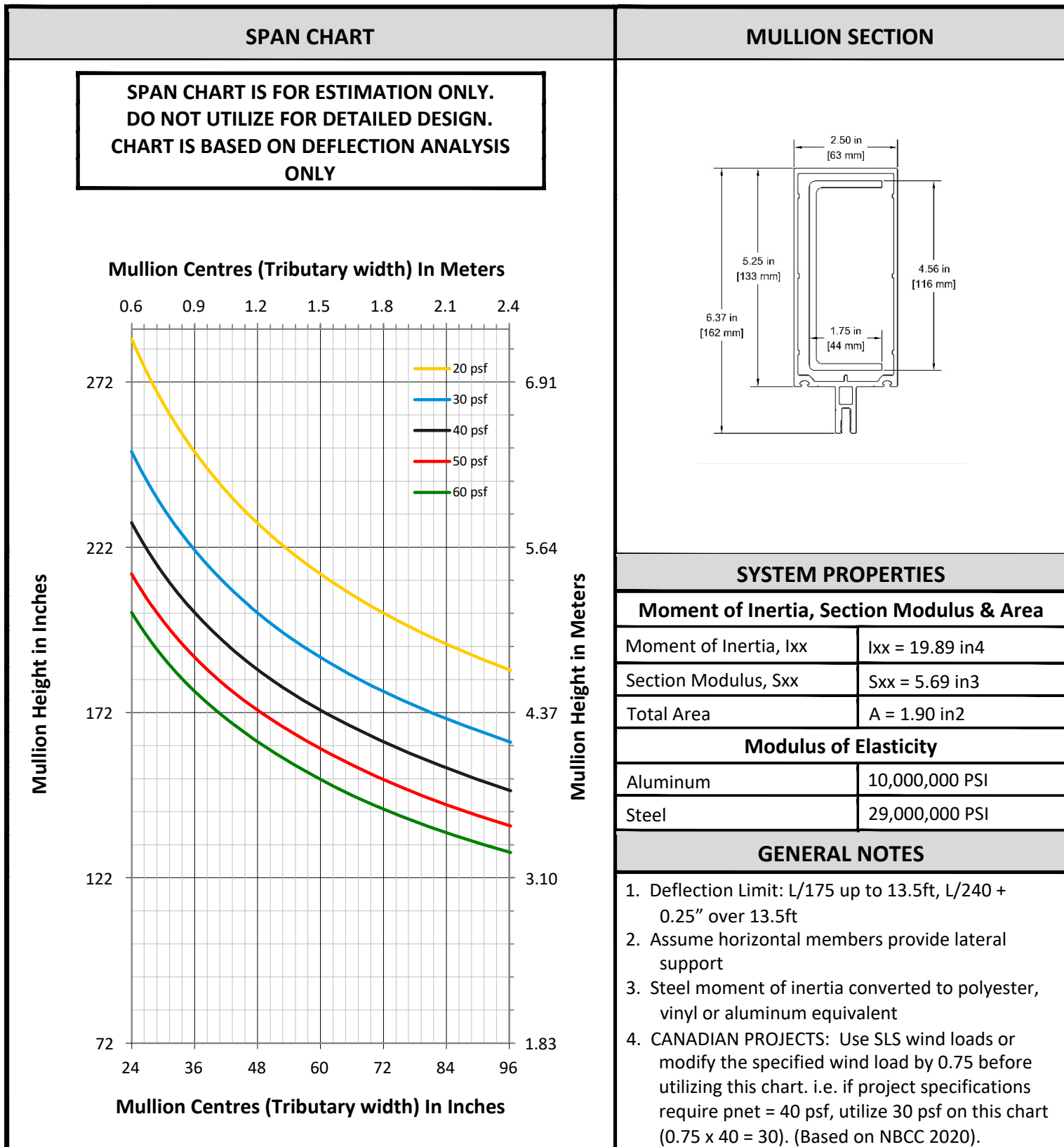

DEAD LOAD CHART FOR 2 1/2" x 5 1/4" MULLION - PART # 2504

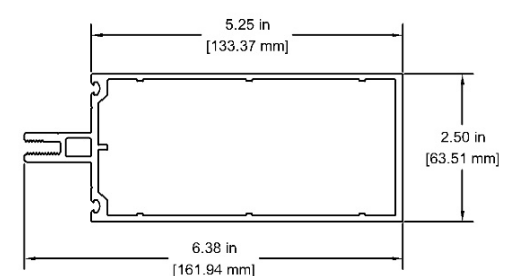
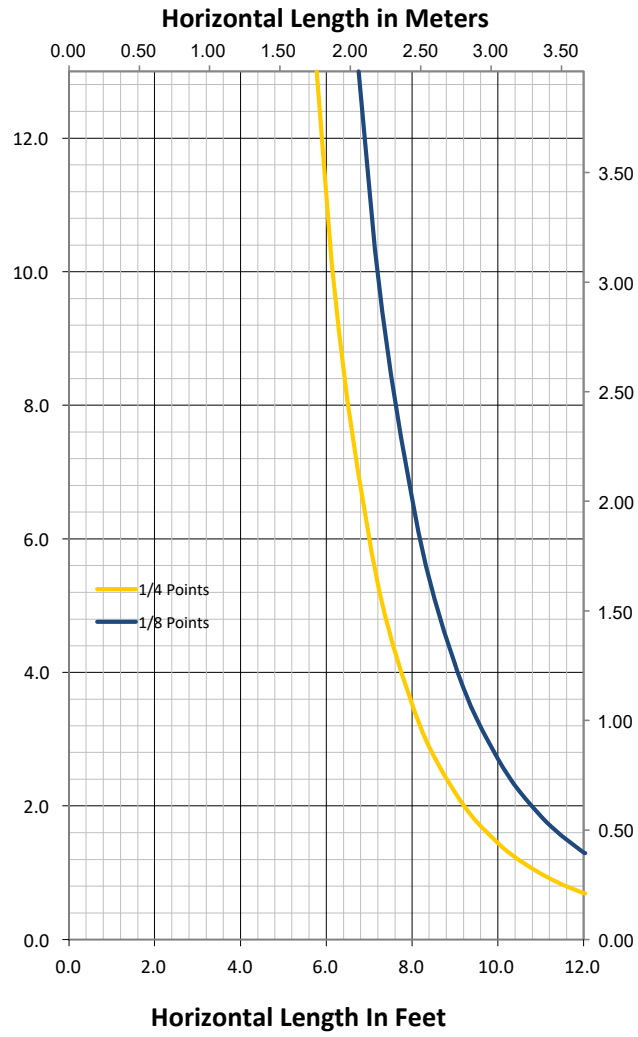
SPAN CHART	MULLION SECTION																				
<p>SPAN CHART IS FOR ESTIMATION ONLY. DO NOT UTILIZE FOR DETAILED DESIGN. CHART IS BASED ON DEFLECTION ANALYSIS ONLY</p>																					
	<table border="1" style="width: 100%; border-collapse: collapse;"> <thead> <tr style="background-color: #cccccc;"> <th colspan="2" style="text-align: center;">SYSTEM PROPERTIES</th> </tr> </thead> <tbody> <tr> <th colspan="2" style="text-align: center;">Moment of Inertia, Section Modulus & Area</th> </tr> <tr> <td style="text-align: left;">Moment of Inertia, I_{yy}</td> <td>I_{yy} = 1.72 in⁴</td> </tr> <tr> <td style="text-align: left;">Section Modulus, S_{yy}</td> <td>S_{yy} = 1.37 in³</td> </tr> <tr> <td style="text-align: left;">Total Area</td> <td>A = 1.90 in²</td> </tr> <tr> <th colspan="2" style="text-align: center;">Modulus of Elasticity</th> </tr> <tr> <td style="text-align: left;">Aluminum</td> <td>10,000,000 PSI</td> </tr> <tr> <td style="text-align: left;">Steel</td> <td>29,000,000 PSI</td> </tr> <tr> <th colspan="2" style="text-align: center;">GENERAL NOTES</th> </tr> <tr> <td colspan="2"> <ol style="list-style-type: none"> 1. Deflection Limit: 0.125" (3.2mm). 2. Charts are calculated assuming a 1" overall sealed unit (6mm/13mm spacer/6mm) 3. Calculations are based on the position of the setting blocks being placed at 1/4 or 1/8 points. </td> </tr> </tbody> </table>	SYSTEM PROPERTIES		Moment of Inertia, Section Modulus & Area		Moment of Inertia, I _{yy}	I _{yy} = 1.72 in ⁴	Section Modulus, S _{yy}	S _{yy} = 1.37 in ³	Total Area	A = 1.90 in ²	Modulus of Elasticity		Aluminum	10,000,000 PSI	Steel	29,000,000 PSI	GENERAL NOTES		<ol style="list-style-type: none"> 1. Deflection Limit: 0.125" (3.2mm). 2. Charts are calculated assuming a 1" overall sealed unit (6mm/13mm spacer/6mm) 3. Calculations are based on the position of the setting blocks being placed at 1/4 or 1/8 points. 	
SYSTEM PROPERTIES																					
Moment of Inertia, Section Modulus & Area																					
Moment of Inertia, I _{yy}	I _{yy} = 1.72 in ⁴																				
Section Modulus, S _{yy}	S _{yy} = 1.37 in ³																				
Total Area	A = 1.90 in ²																				
Modulus of Elasticity																					
Aluminum	10,000,000 PSI																				
Steel	29,000,000 PSI																				
GENERAL NOTES																					
<ol style="list-style-type: none"> 1. Deflection Limit: 0.125" (3.2mm). 2. Charts are calculated assuming a 1" overall sealed unit (6mm/13mm spacer/6mm) 3. Calculations are based on the position of the setting blocks being placed at 1/4 or 1/8 points. 																					

WIND LOAD CHART FOR 2 1/2" x 5 1/4" SSG MULLION - PART # 2555

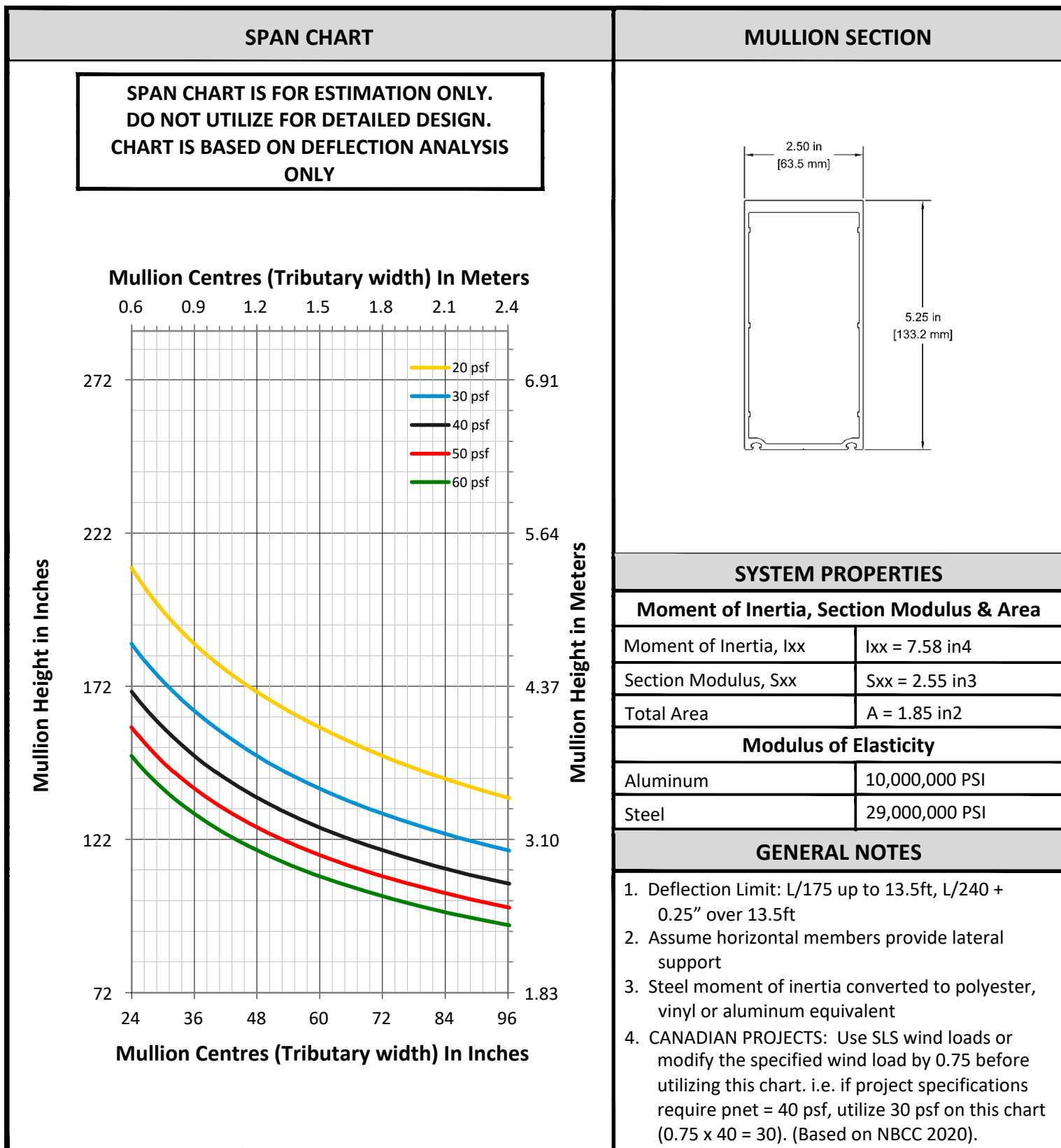

STEEL LOADED WIND LOAD CHART FOR 2 1/2" x 5 1/4" SSG MULLION - PART # 2555

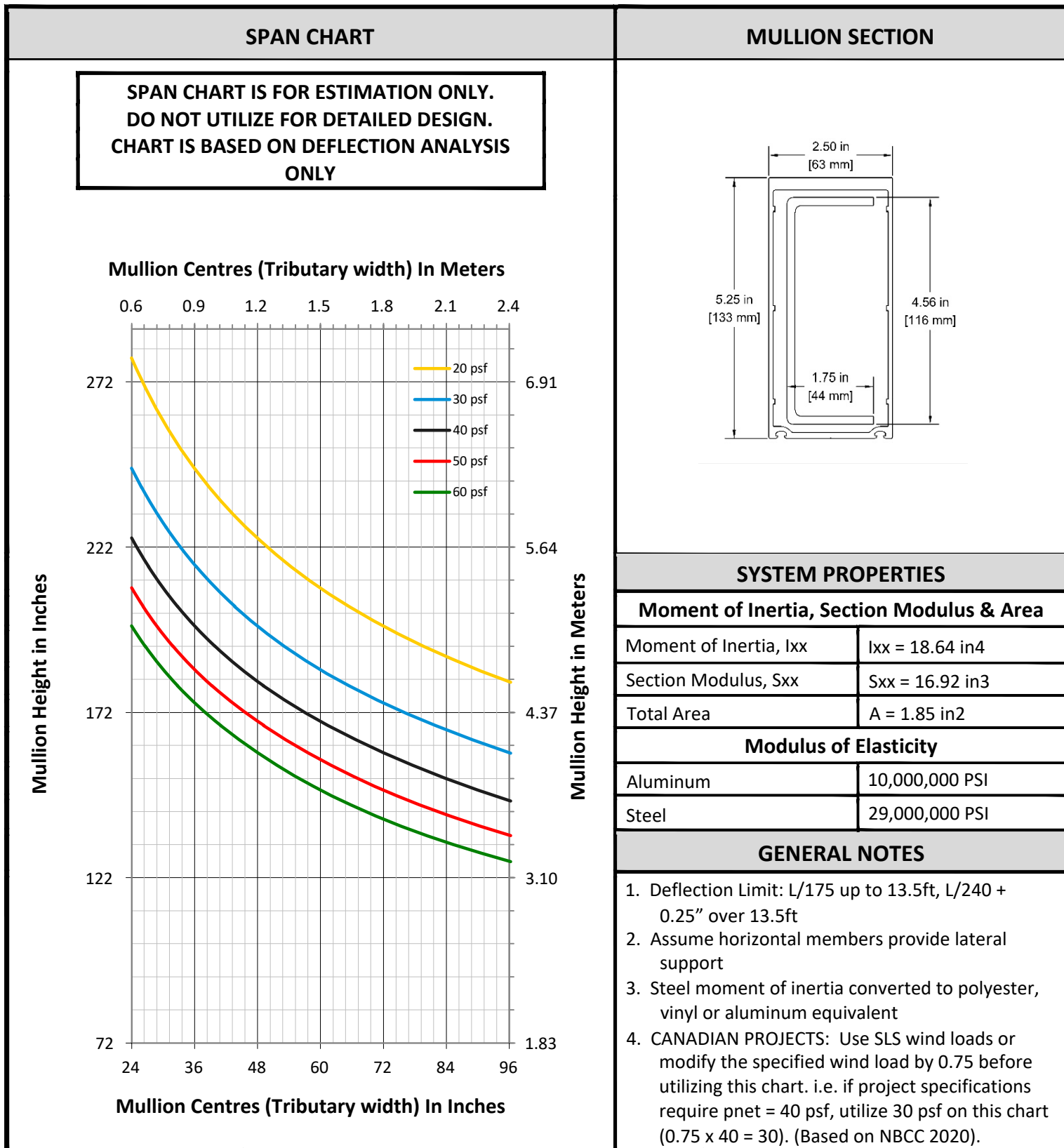

DEAD LOAD CHART FOR 2 1/2" x 5 1/4" SSG MULLION - PART # 2555

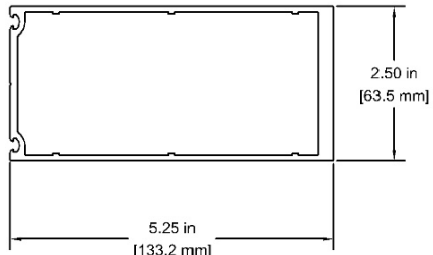
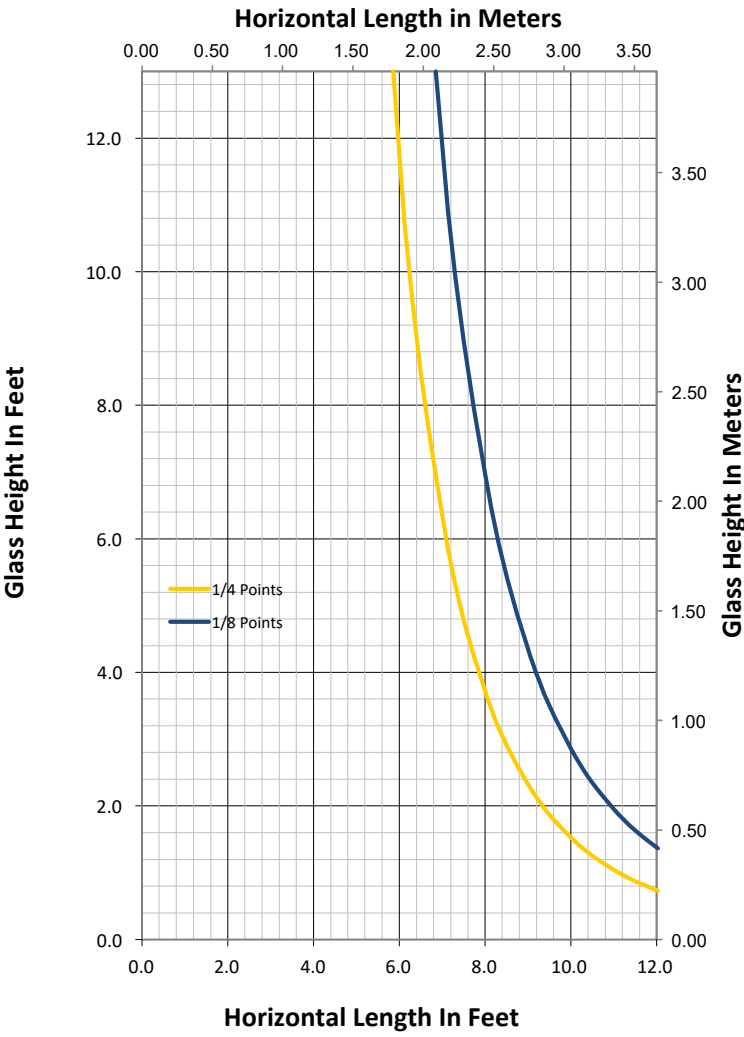
SPAN CHART	MULLION SECTION																				
<p>SPAN CHART IS FOR ESTIMATION ONLY. DO NOT UTILIZE FOR DETAILED DESIGN. CHART IS BASED ON DEFLECTION ANALYSIS ONLY</p>																					
	<table border="1" style="width: 100%; border-collapse: collapse;"> <thead> <tr style="background-color: #cccccc;"> <th colspan="2" style="text-align: center;">SYSTEM PROPERTIES</th> </tr> </thead> <tbody> <tr style="background-color: #cccccc;"> <th colspan="2" style="text-align: center;">Moment of Inertia, Section Modulus & Area</th> </tr> <tr> <td style="text-align: left;">Moment of Inertia, I_{yy}</td> <td style="text-align: right;">$I_{yy} = 1.81 \text{ in}^4$</td> </tr> <tr> <td style="text-align: left;">Section Modulus, S_{yy}</td> <td style="text-align: right;">$S_{yy} = 1.45 \text{ in}^3$</td> </tr> <tr> <td style="text-align: left;">Total Area</td> <td style="text-align: right;">$A = 1.85 \text{ in}^2$</td> </tr> <tr style="background-color: #cccccc;"> <th colspan="2" style="text-align: center;">Modulus of Elasticity</th> </tr> <tr> <td style="text-align: left;">Aluminum</td> <td style="text-align: right;">10,000,000 PSI</td> </tr> <tr> <td style="text-align: left;">Steel</td> <td style="text-align: right;">29,000,000 PSI</td> </tr> <tr style="background-color: #cccccc;"> <th colspan="2" style="text-align: center;">GENERAL NOTES</th> </tr> <tr> <td colspan="2"> <ol style="list-style-type: none"> 1. Deflection Limit: 0.125" (3.2mm). 2. Charts are calculated assuming a 1" overall sealed unit (6mm/13mm spacer/6mm) 3. Calculations are based on the position of the setting blocks being placed at 1/4 or 1/8 points. </td> </tr> </tbody> </table>	SYSTEM PROPERTIES		Moment of Inertia, Section Modulus & Area		Moment of Inertia, I_{yy}	$I_{yy} = 1.81 \text{ in}^4$	Section Modulus, S_{yy}	$S_{yy} = 1.45 \text{ in}^3$	Total Area	$A = 1.85 \text{ in}^2$	Modulus of Elasticity		Aluminum	10,000,000 PSI	Steel	29,000,000 PSI	GENERAL NOTES		<ol style="list-style-type: none"> 1. Deflection Limit: 0.125" (3.2mm). 2. Charts are calculated assuming a 1" overall sealed unit (6mm/13mm spacer/6mm) 3. Calculations are based on the position of the setting blocks being placed at 1/4 or 1/8 points. 	
SYSTEM PROPERTIES																					
Moment of Inertia, Section Modulus & Area																					
Moment of Inertia, I_{yy}	$I_{yy} = 1.81 \text{ in}^4$																				
Section Modulus, S_{yy}	$S_{yy} = 1.45 \text{ in}^3$																				
Total Area	$A = 1.85 \text{ in}^2$																				
Modulus of Elasticity																					
Aluminum	10,000,000 PSI																				
Steel	29,000,000 PSI																				
GENERAL NOTES																					
<ol style="list-style-type: none"> 1. Deflection Limit: 0.125" (3.2mm). 2. Charts are calculated assuming a 1" overall sealed unit (6mm/13mm spacer/6mm) 3. Calculations are based on the position of the setting blocks being placed at 1/4 or 1/8 points. 																					

WIND LOAD CHART FOR 2 1/2" x 8" MULLION - PART # 2580

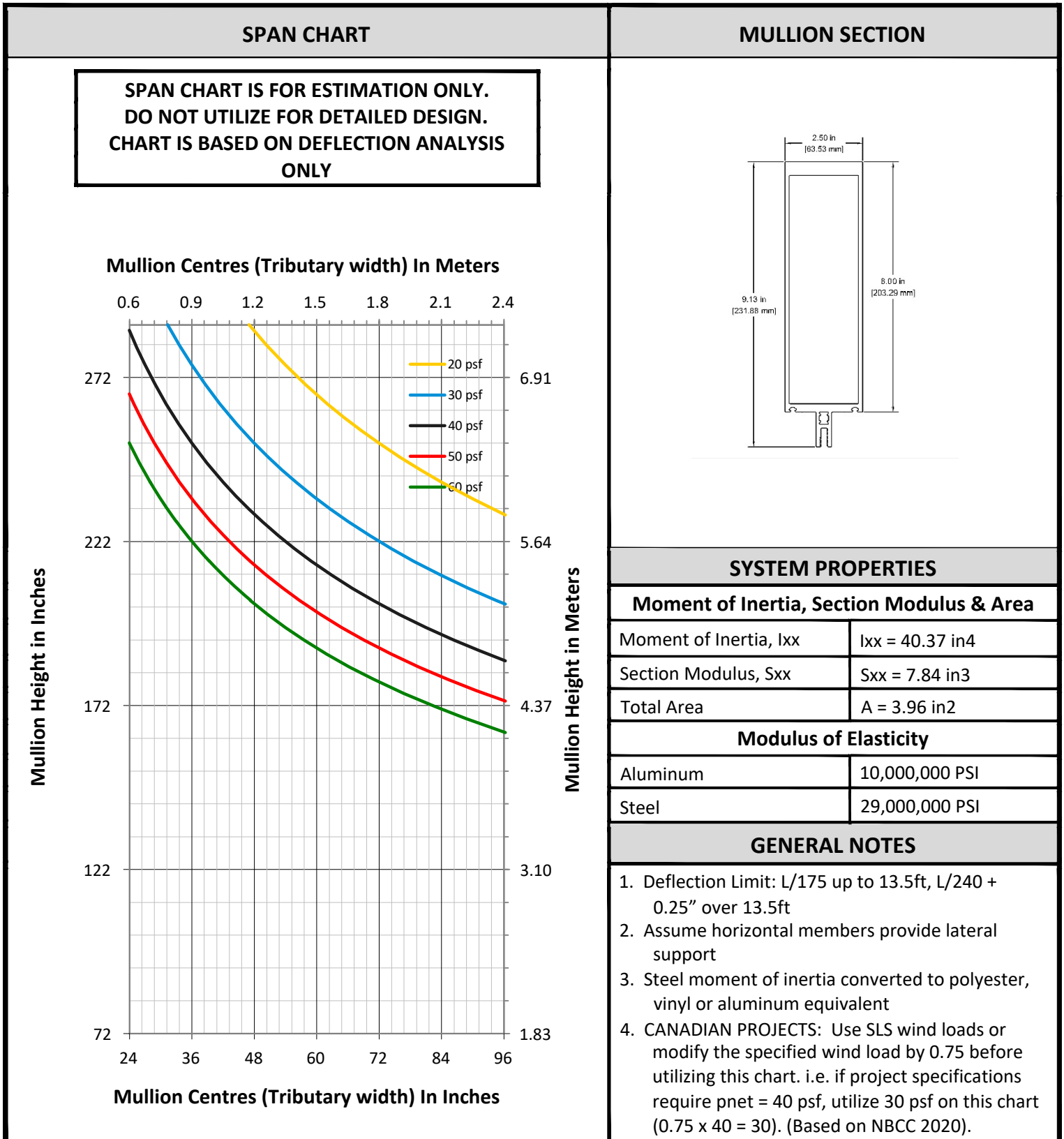

STEEL LOADED WIND LOAD CHART FOR 2 1/2" x 8" MULLION - PART # 2580

SPAN CHART

SPAN CHART IS FOR ESTIMATION ONLY.
DO NOT UTILIZE FOR DETAILED DESIGN.
CHART IS BASED ON DEFLECTION ANALYSIS
ONLY

Mullion Centres (Tributary width) In Meters

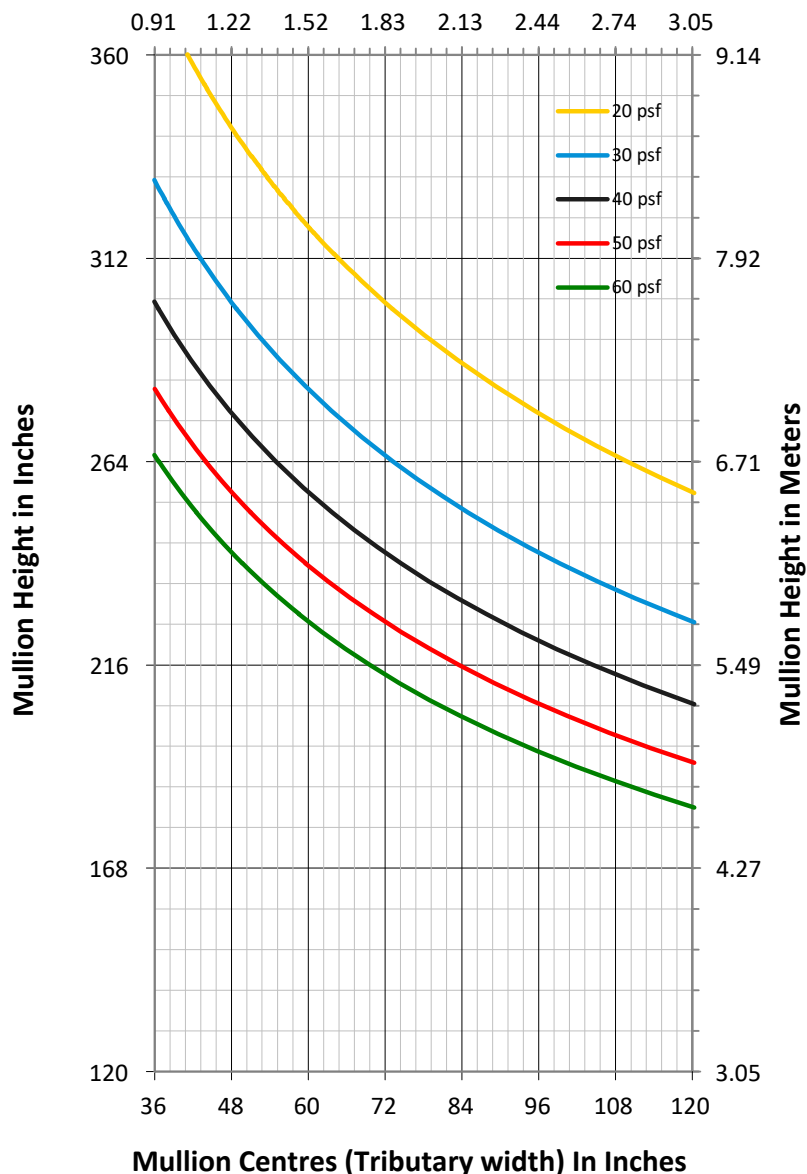

MULLION SECTION

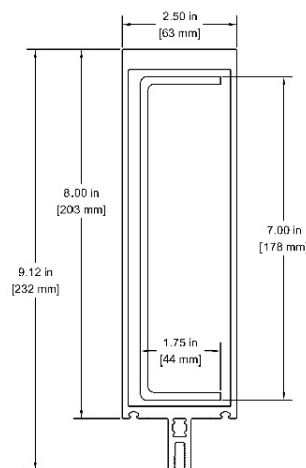

SYSTEM PROPERTIES

Moment of Inertia, Section Modulus & Area

Moment of Inertia, I _{xx}	I _{xx} = 71.48 in ⁴
Section Modulus, S _{xx}	S _{xx} = 14.07 in ³
Total Area	A = 3.96 in ²

Modulus of Elasticity

Aluminum	10,000,000 PSI
Steel	29,000,000 PSI

GENERAL NOTES

1. Deflection Limit: L/175 up to 13.5ft, L/240 + 0.25" over 13.5ft
2. Assume horizontal members provide lateral support
3. Steel moment of inertia converted to polyester, vinyl or aluminum equivalent
4. CANADIAN PROJECTS: Use SLS wind loads or modify the specified wind load by 0.75 before utilizing this chart. i.e. if project specifications require pnet = 40 psf, utilize 30 psf on this chart (0.75 x 40 = 30). (Based on NBCC 2020).

DEAD LOAD CHART FOR 2 1/2" x 8" MULLION - PART # 2580

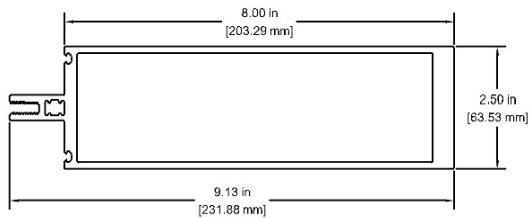
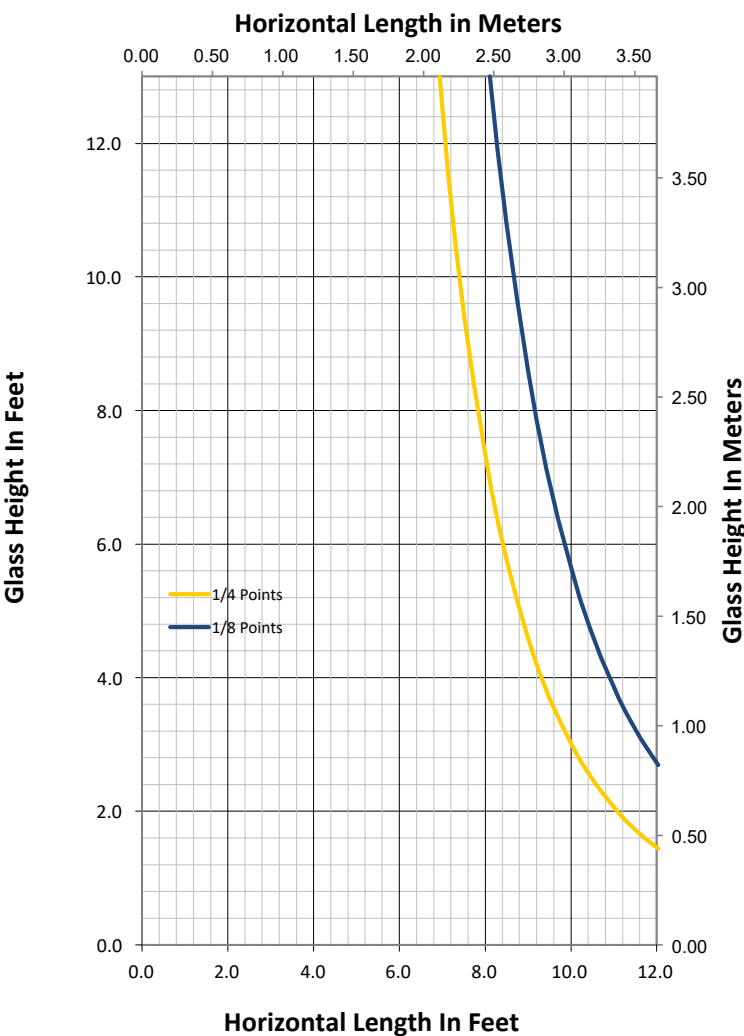
SPAN CHART	MULLION SECTION																				
<p>SPAN CHART IS FOR ESTIMATION ONLY. DO NOT UTILIZE FOR DETAILED DESIGN. CHART IS BASED ON DEFLECTION ANALYSIS ONLY</p>																					
	<table border="1" style="width: 100%; border-collapse: collapse;"> <thead> <tr style="background-color: #cccccc;"> <th colspan="2" style="text-align: center;">SYSTEM PROPERTIES</th> </tr> </thead> <tbody> <tr> <th colspan="2" style="text-align: center;">Moment of Inertia, Section Modulus & Area</th> </tr> <tr> <td style="text-align: left;">Moment of Inertia, I_{yy}</td> <td>I_{yy} = 3.58 in⁴</td> </tr> <tr> <td style="text-align: left;">Section Modulus, S_{yy}</td> <td>S_{yy} = 2.86 in³</td> </tr> <tr> <td style="text-align: left;">Total Area</td> <td>A = 3.96 in²</td> </tr> <tr> <th colspan="2" style="text-align: center;">Modulus of Elasticity</th> </tr> <tr> <td style="text-align: left;">Aluminum</td> <td>10,000,000 PSI</td> </tr> <tr> <td style="text-align: left;">Steel</td> <td>29,000,000 PSI</td> </tr> <tr style="background-color: #cccccc;"> <th colspan="2" style="text-align: center;">GENERAL NOTES</th> </tr> <tr> <td colspan="2"> <ol style="list-style-type: none"> 1. Deflection Limit: 0.125" (3.2mm). 2. Charts are calculated assuming a 1" overall sealed unit (6mm/13mm spacer/6mm) 3. Calculations are based on the position of the setting blocks being placed at 1/4 or 1/8 points. </td> </tr> </tbody> </table>	SYSTEM PROPERTIES		Moment of Inertia, Section Modulus & Area		Moment of Inertia, I _{yy}	I _{yy} = 3.58 in ⁴	Section Modulus, S _{yy}	S _{yy} = 2.86 in ³	Total Area	A = 3.96 in ²	Modulus of Elasticity		Aluminum	10,000,000 PSI	Steel	29,000,000 PSI	GENERAL NOTES		<ol style="list-style-type: none"> 1. Deflection Limit: 0.125" (3.2mm). 2. Charts are calculated assuming a 1" overall sealed unit (6mm/13mm spacer/6mm) 3. Calculations are based on the position of the setting blocks being placed at 1/4 or 1/8 points. 	
SYSTEM PROPERTIES																					
Moment of Inertia, Section Modulus & Area																					
Moment of Inertia, I _{yy}	I _{yy} = 3.58 in ⁴																				
Section Modulus, S _{yy}	S _{yy} = 2.86 in ³																				
Total Area	A = 3.96 in ²																				
Modulus of Elasticity																					
Aluminum	10,000,000 PSI																				
Steel	29,000,000 PSI																				
GENERAL NOTES																					
<ol style="list-style-type: none"> 1. Deflection Limit: 0.125" (3.2mm). 2. Charts are calculated assuming a 1" overall sealed unit (6mm/13mm spacer/6mm) 3. Calculations are based on the position of the setting blocks being placed at 1/4 or 1/8 points. 																					



**METRO
ALUMINUM**

Products Ltd.

2500T SERIES

THERMALLY BROKEN
CURTAIN WALL & WINDOW SYSTEM
2 1/2" (63.5 mm) - FRAME

D

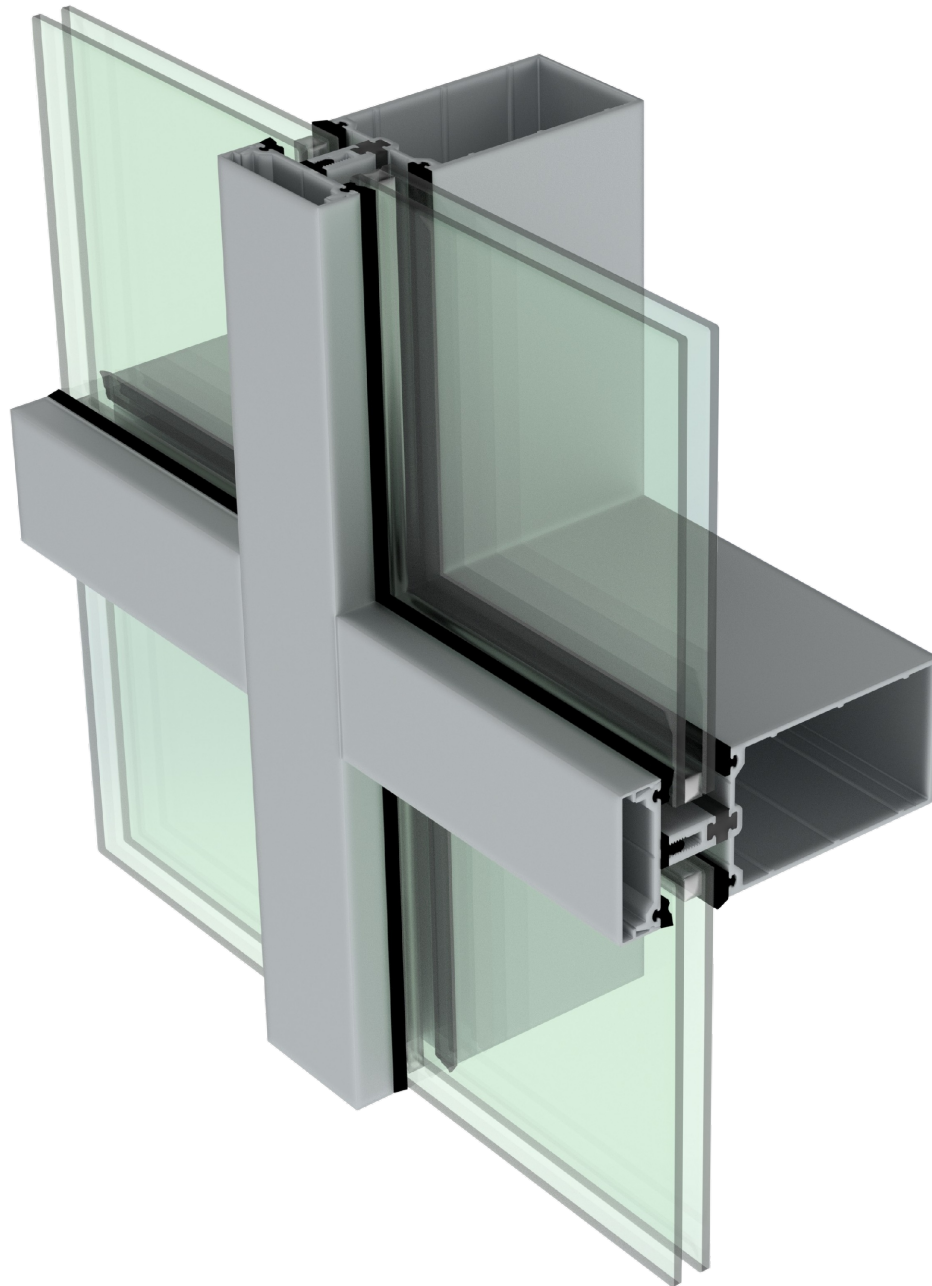



**METRO
ALUMINUM**
Products Ltd.

2500T SERIES

THERMALLY BROKEN
CURTAIN WALL & WINDOW SYSTEM
2 1/2" (63.5 mm) - FRAME

**D
45**

BACK SECTIONS

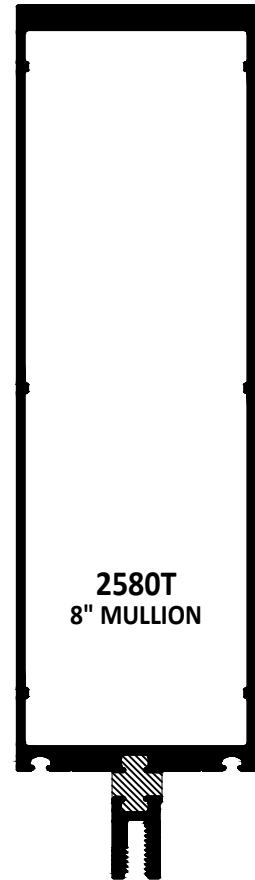
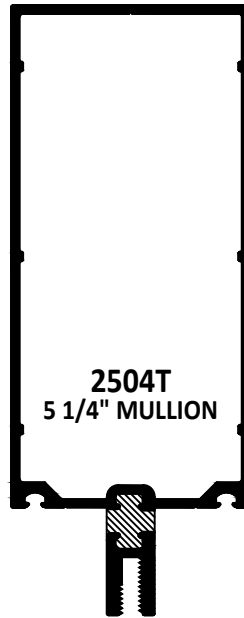
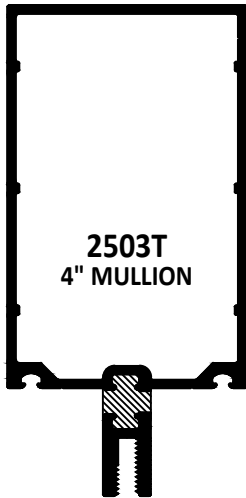

2505
PRESSURE PLATE



2507
1 1/4" CAP



2505F
FIBRE GLASS PRESSURE PLATE

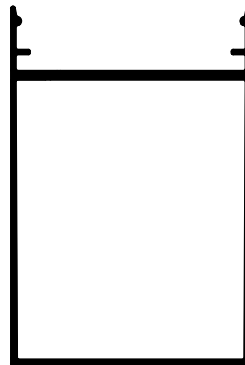

2508
3 3/4" CAP



2506
3/4" CAP



**METRO
ALUMINUM**
Products Ltd.

2500T SERIES

THERMALLY BROKEN
CURTAIN WALL & WINDOW SYSTEM
2 1/2" (63.5 mm) - FRAME

**D
46**

SSG COMPONENTS

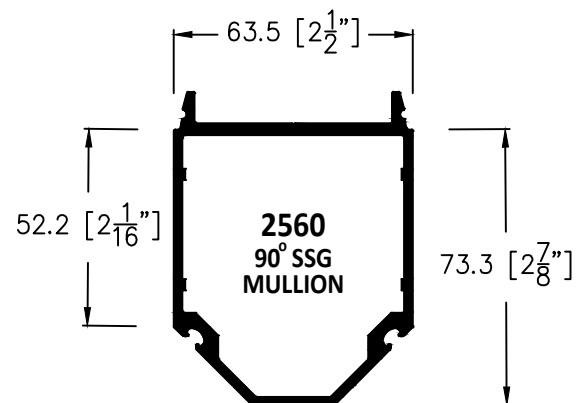
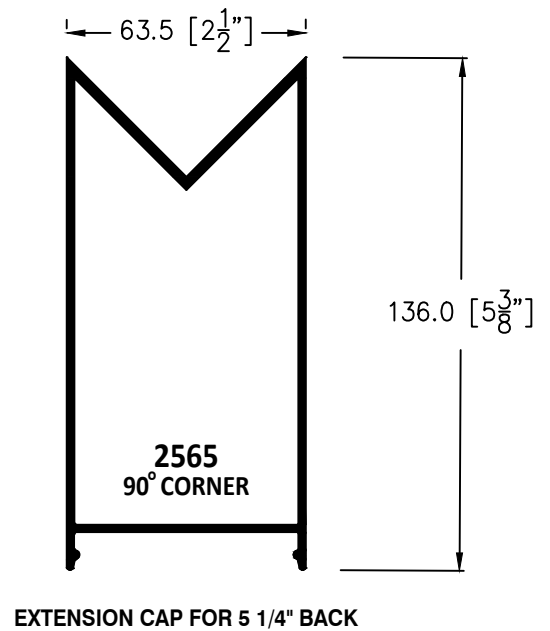
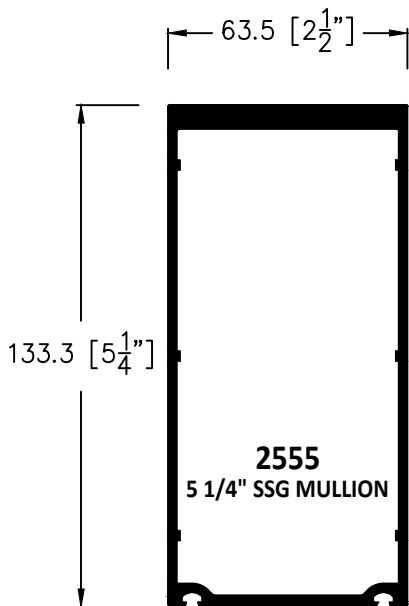
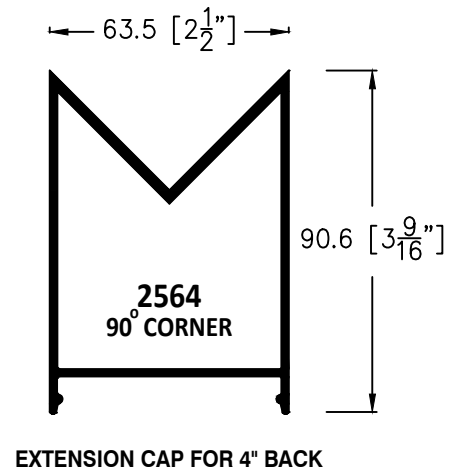
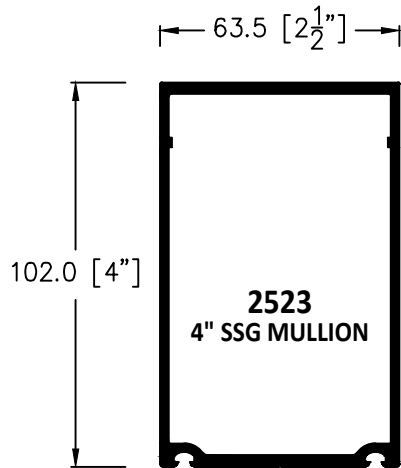



MISC. COMPONENTS



2410
THERMAL BREAK



2515
CORNER BLOCK



2460
SPONGE GASKET
(INTERIOR)



2450
DENSE GASKET
(EXTERIOR)

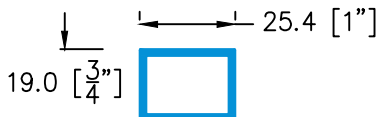

7501
PVC
ANTI-ROTATION

2435
DOOR
ADAPTER

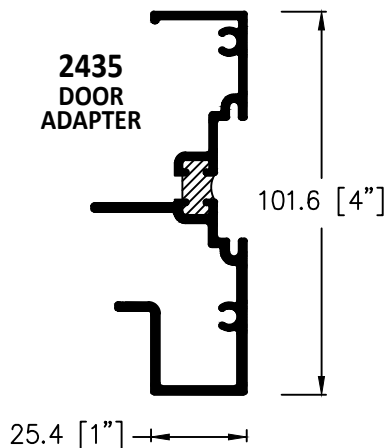

2520
SPIGOT

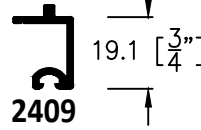

2409
SINGLE GLASS
ADAPTOR

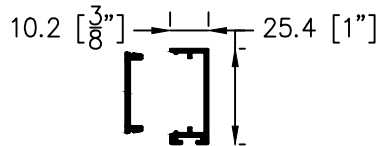

2417/2418
SURFACE APPLIED
DOOR STOP



20120T
DOOR STOP
FOR 2" DOORS



2012T
DOOR STOP
FOR 1 3/4" DOORS

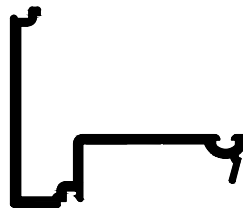

2517
FLUSH DOOR
ADAPTOR



2518
FLUSH DOOR
ADAPTOR CAP



5102
1" X 2" PERIMETER ANGLE



5103
1" X 3" PERIMETER ANGLE

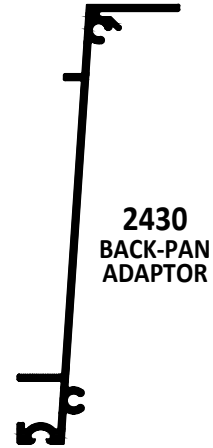

2430
BACK-PAN
ADAPTOR



TYPICAL DETAILS

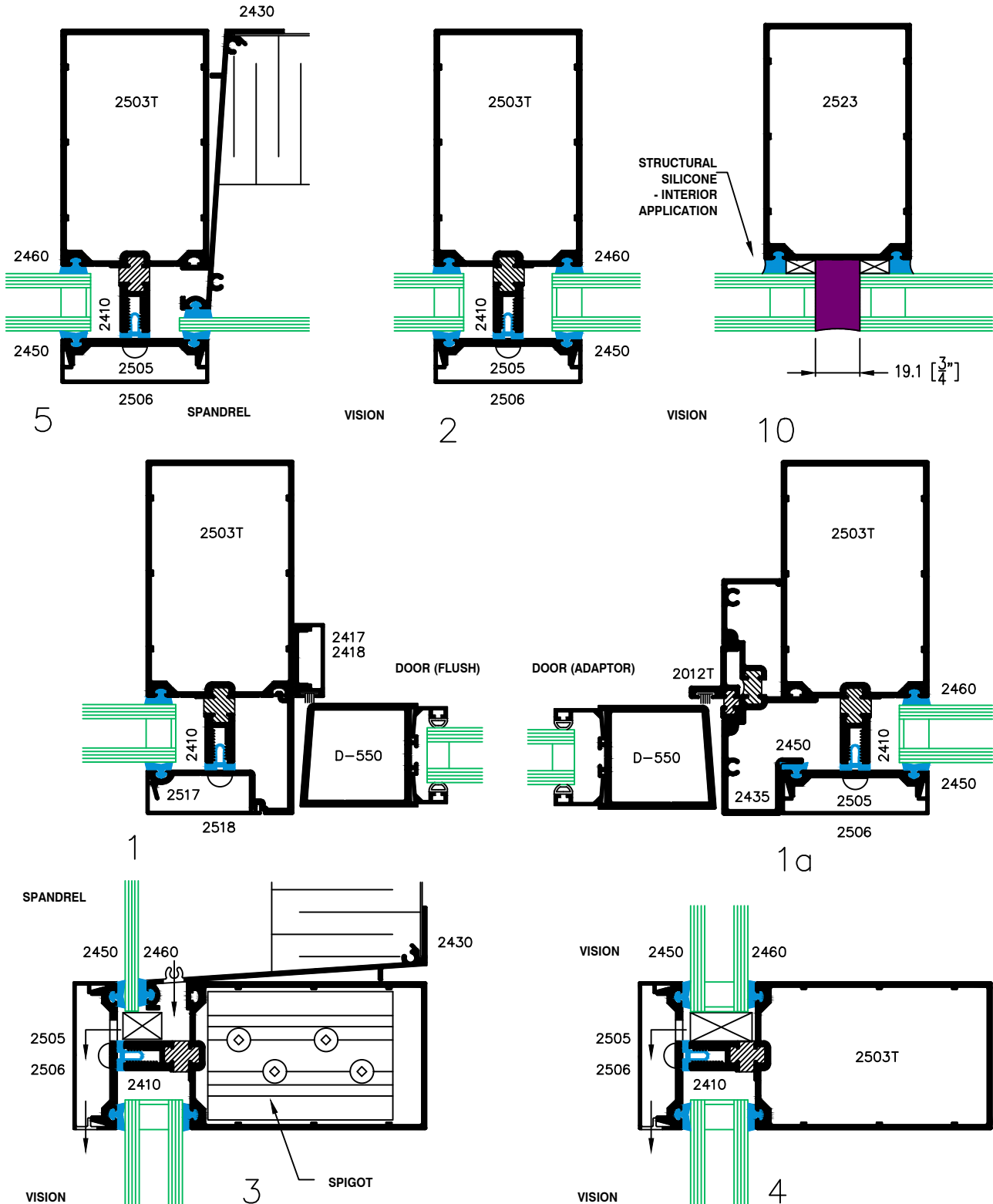

TYPICAL DETAILS

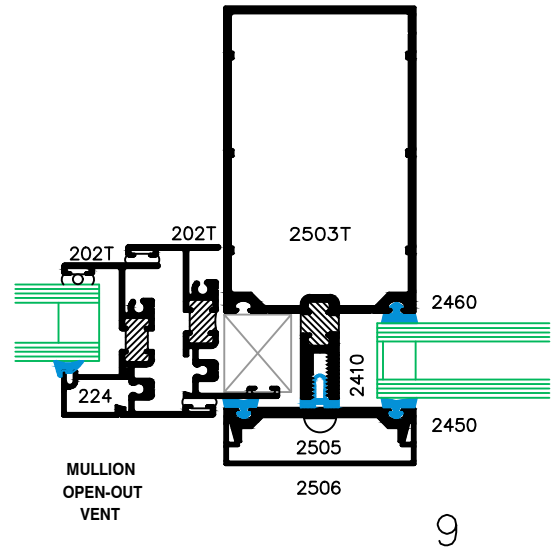
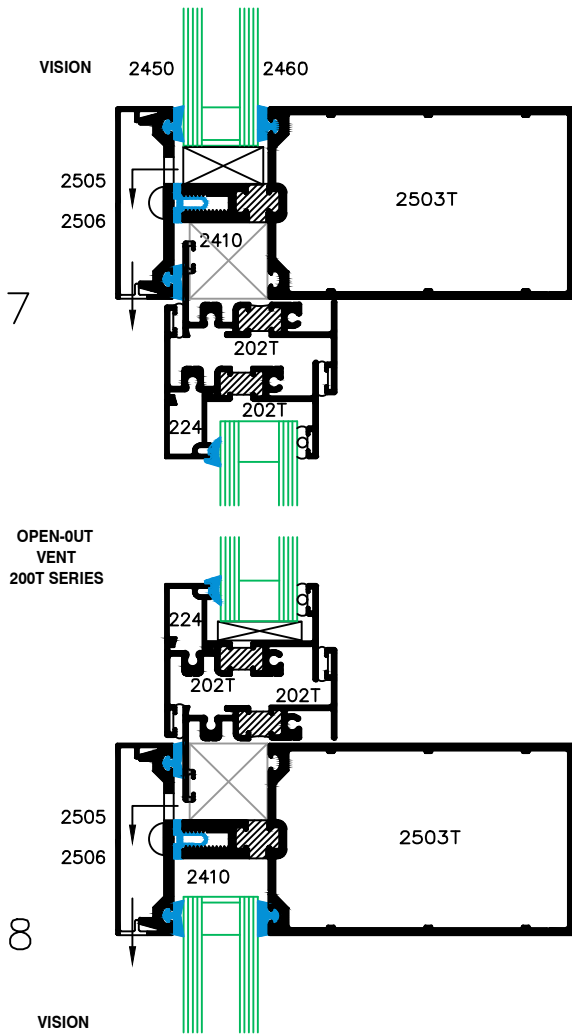

TYPICAL CAPTURED CORNER DETAILS

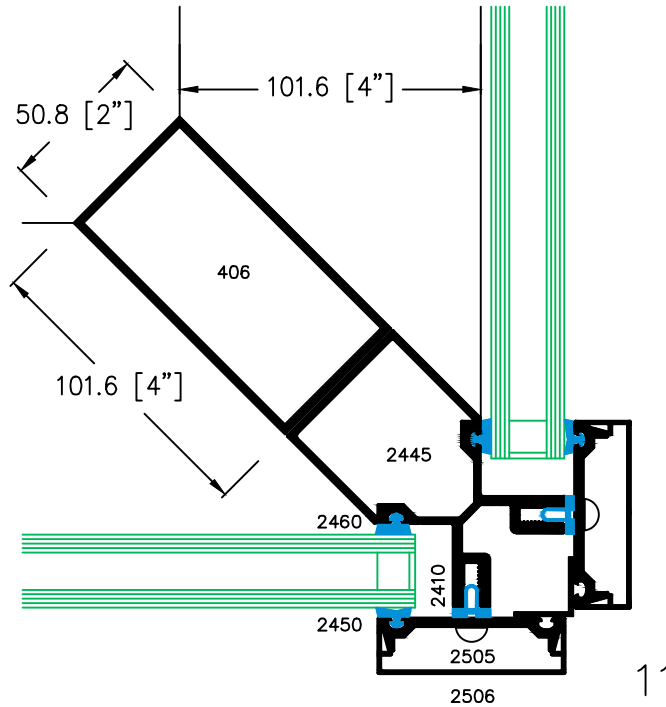

11

90° CAPTURED CORNER

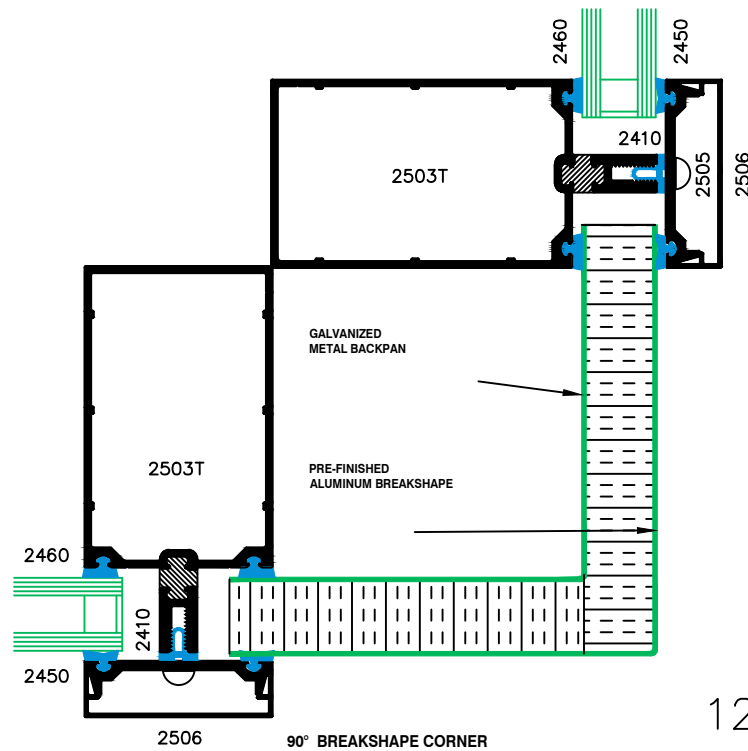

12

90° BREAKSHAPE CORNER

TYPICAL BUTT-JOINT CORNER DETAILS

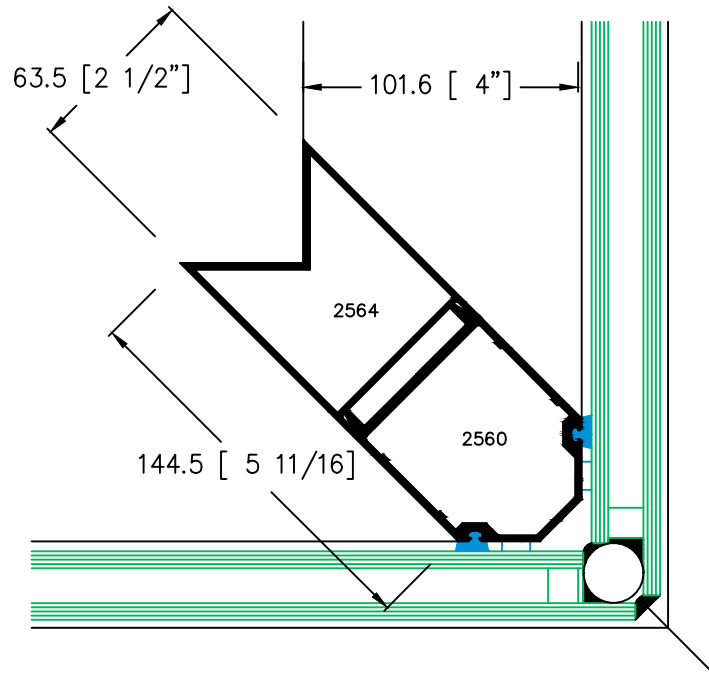

90° BUTT-JOINT CORNER
AT 4" BACK MEMBER

12

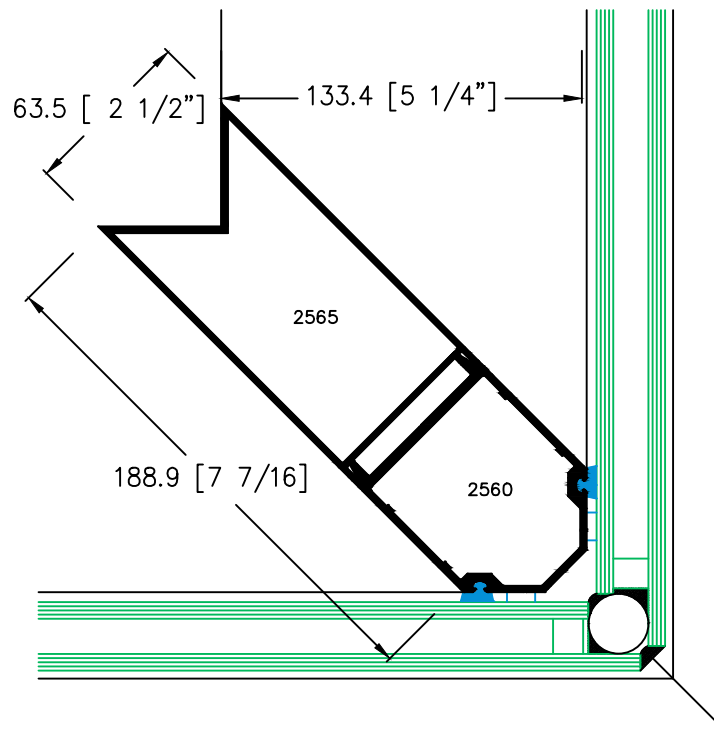

90° BUTT-JOINT CORNER
AT 5 1/4" BACK MEMBER

13

ALTERNATE DOOR DETAILS

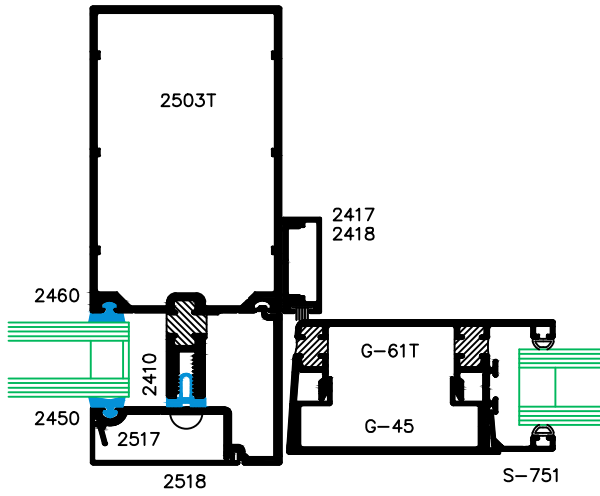

GLACIER DOOR

15

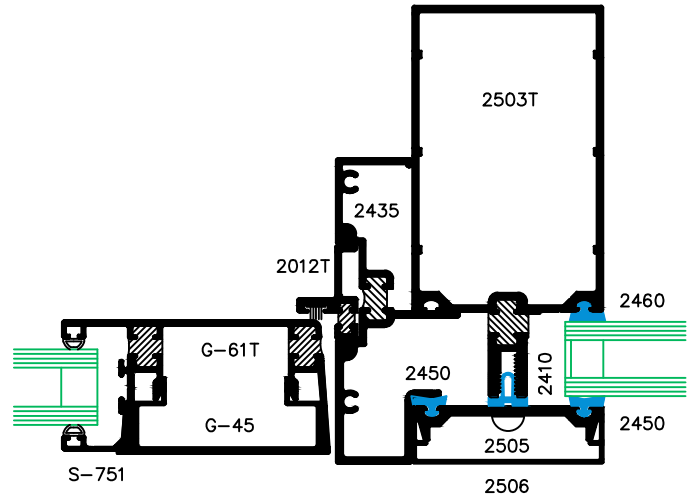

SWING DOORS

15a

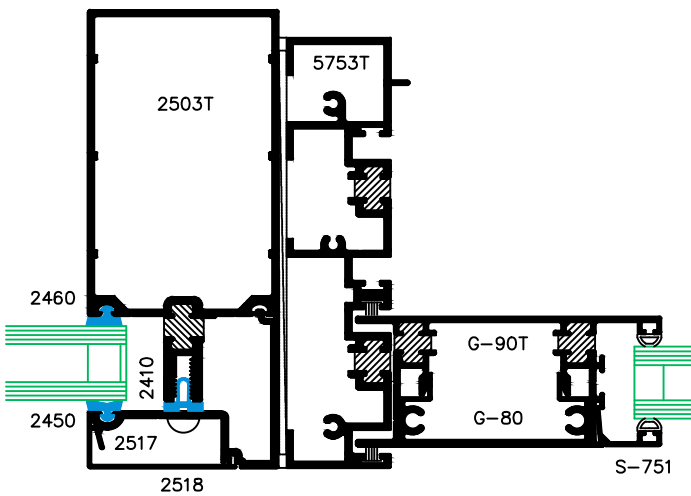

1100T JAMB AT SLIDER

16

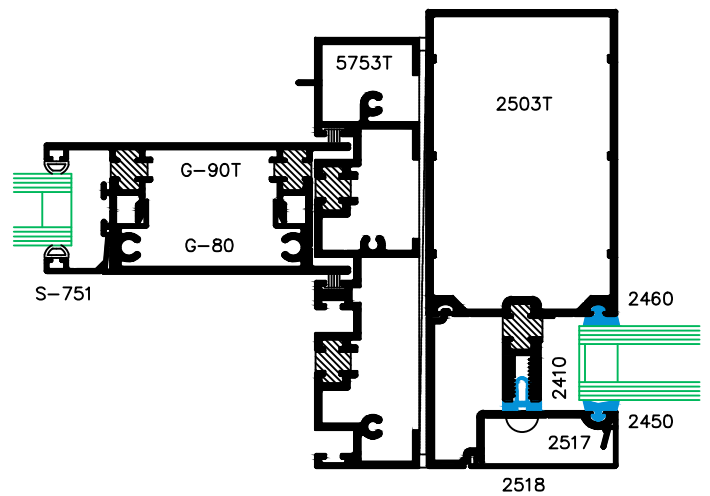

SLIDING DOORS

16a



**INTERFACE DETAILS
(SUGGESTED ONLY)**

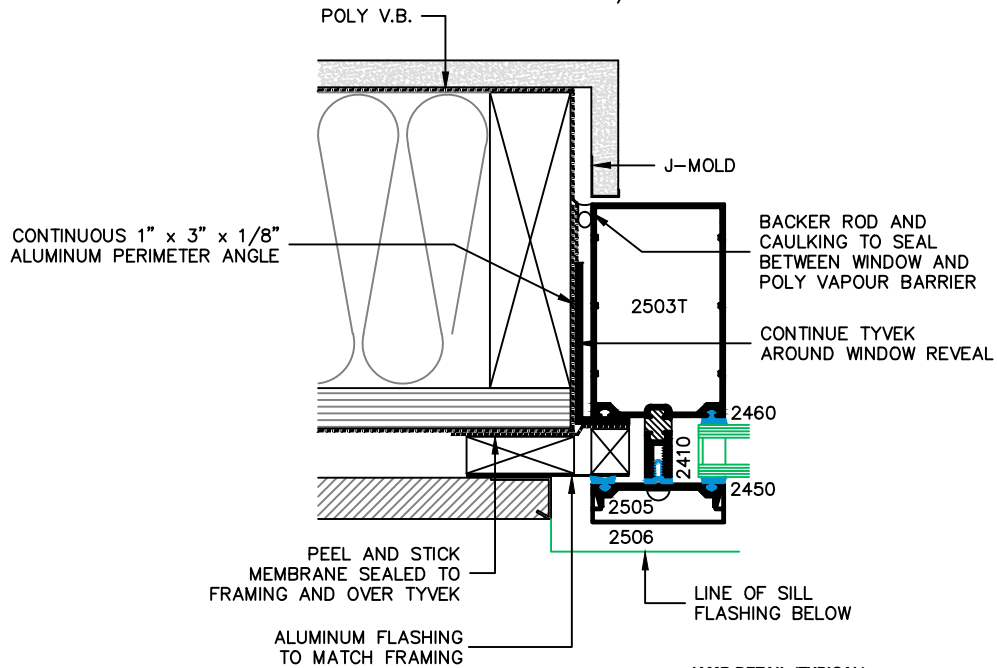
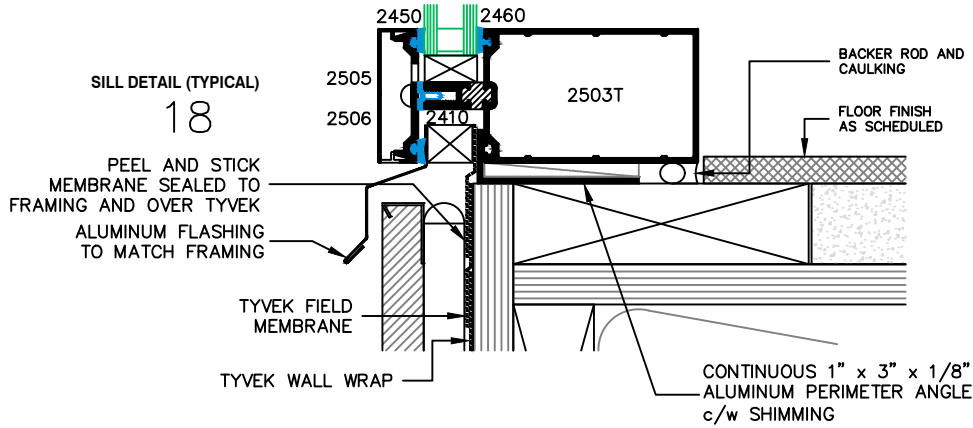
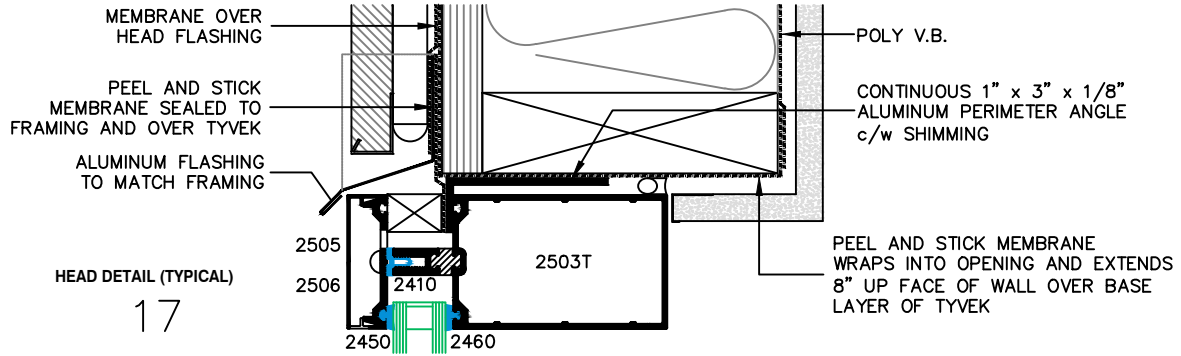



**METRO
ALUMINUM**
Products Ltd.

2500T SERIES

THERMALLY BROKEN
CURTAIN WALL & WINDOW SYSTEM
2 1/2" (63.5 mm) - FRAME

**D
48F**

TYPICAL ANCHORING DETAILS

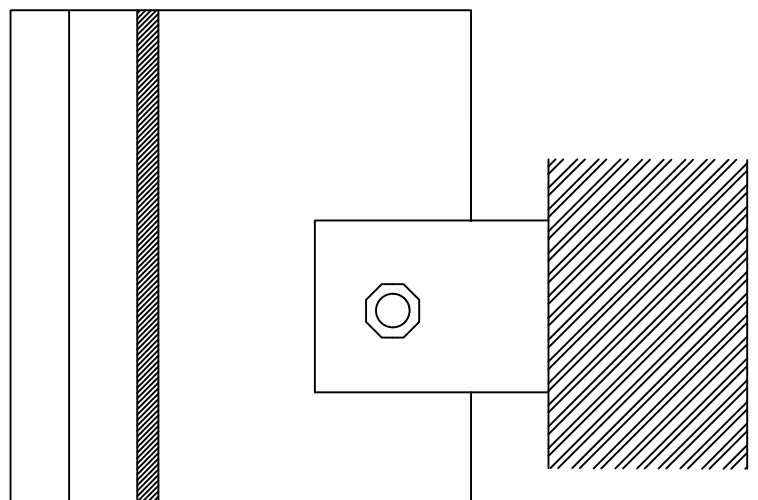
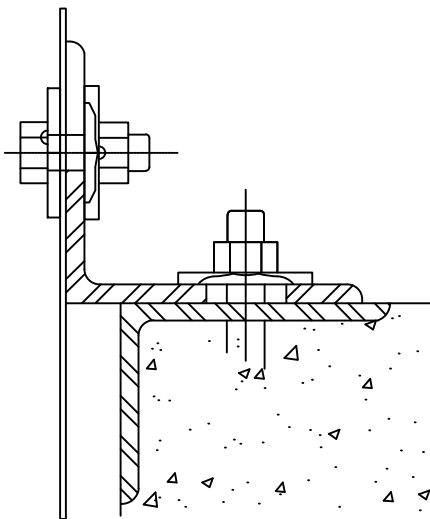
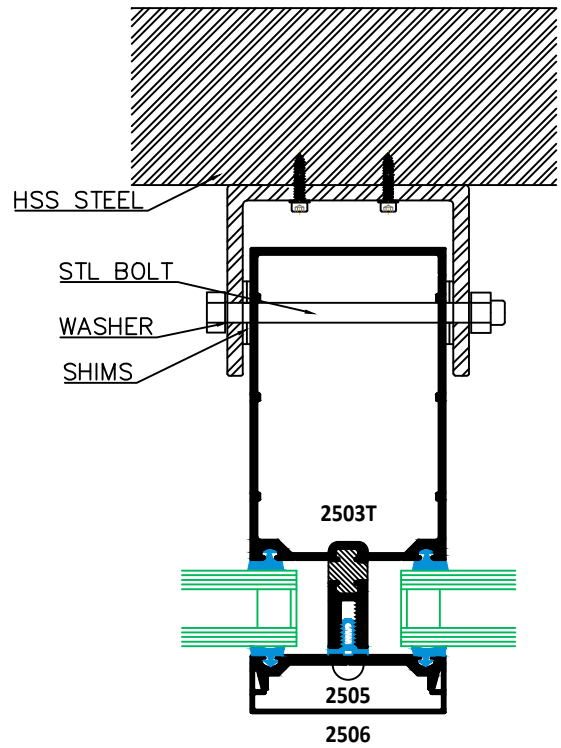
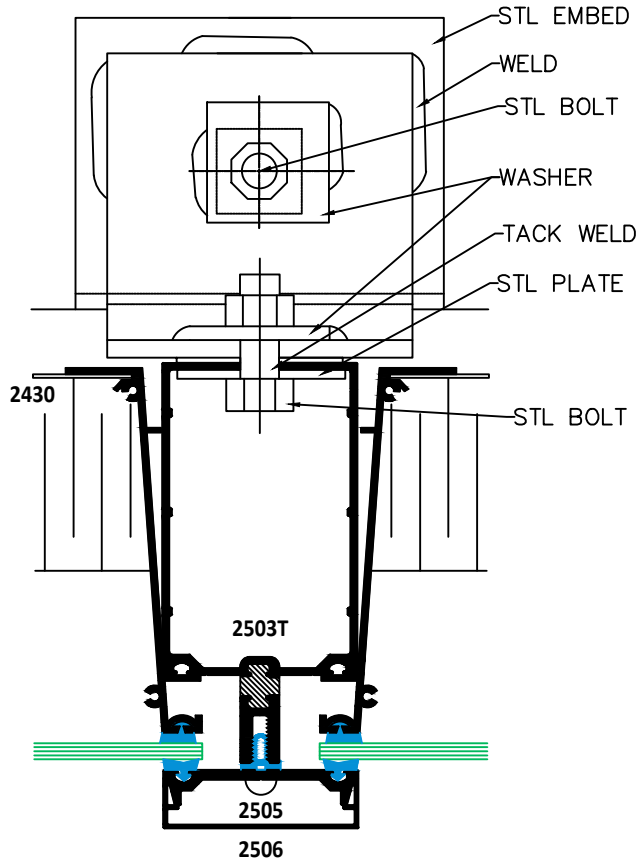

SECTION DETAILS

EXPANSION & SPLICE DETAILS

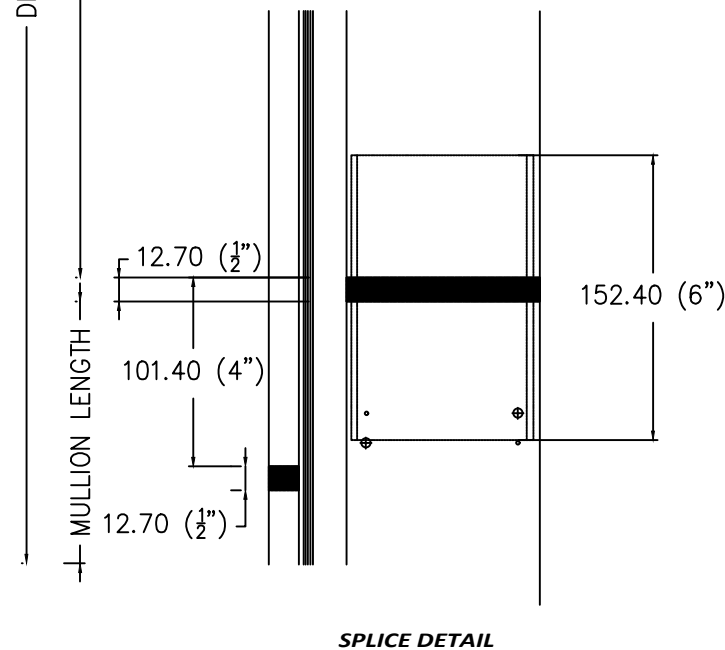
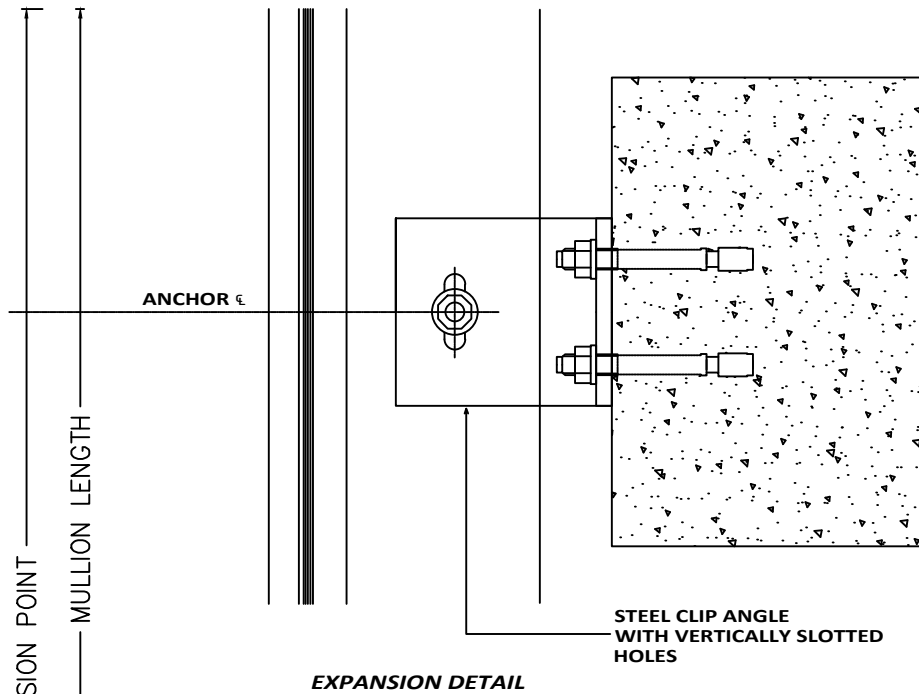

WIND LOAD CHART FOR 2 1/2" x 4" T/B MULLION - PART # 2503T

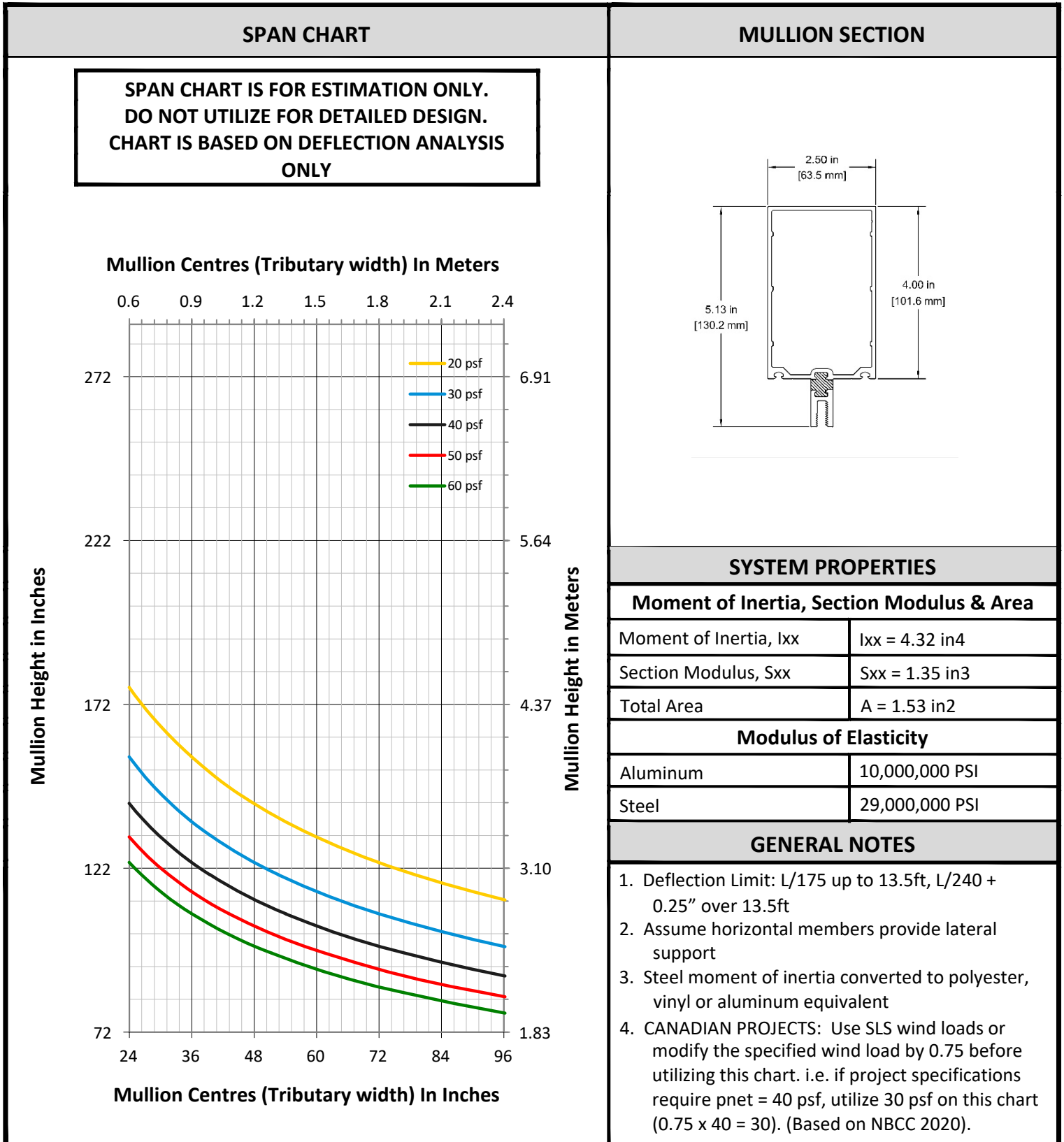

STEEL LOADED WIND LOAD CHART FOR 2 1/2" x 4" T/B MULLION - PART # 2503T

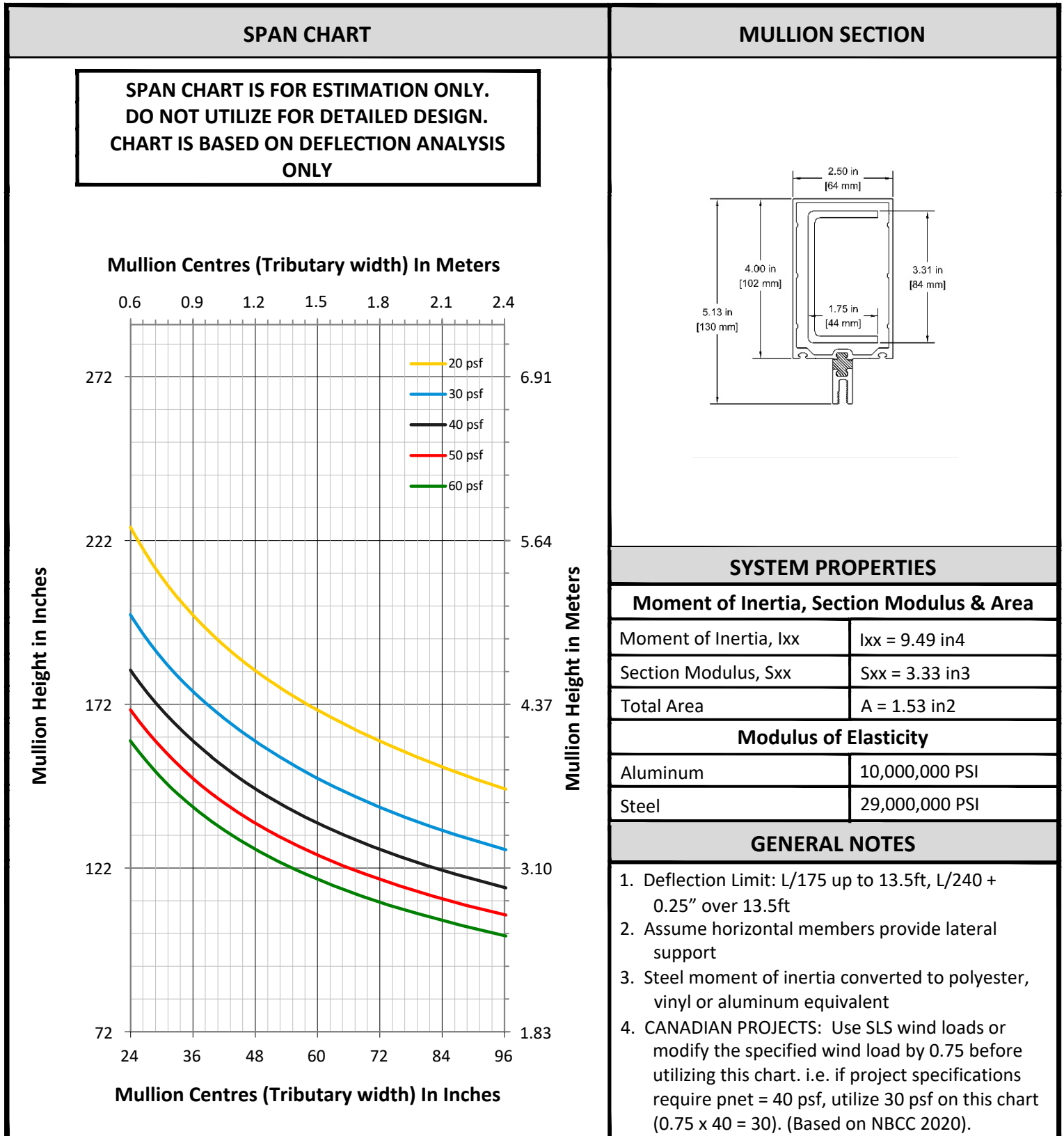

DEAD LOAD CHART FOR 2 1/2" x 4" T/B MULLION - PART # 2503T

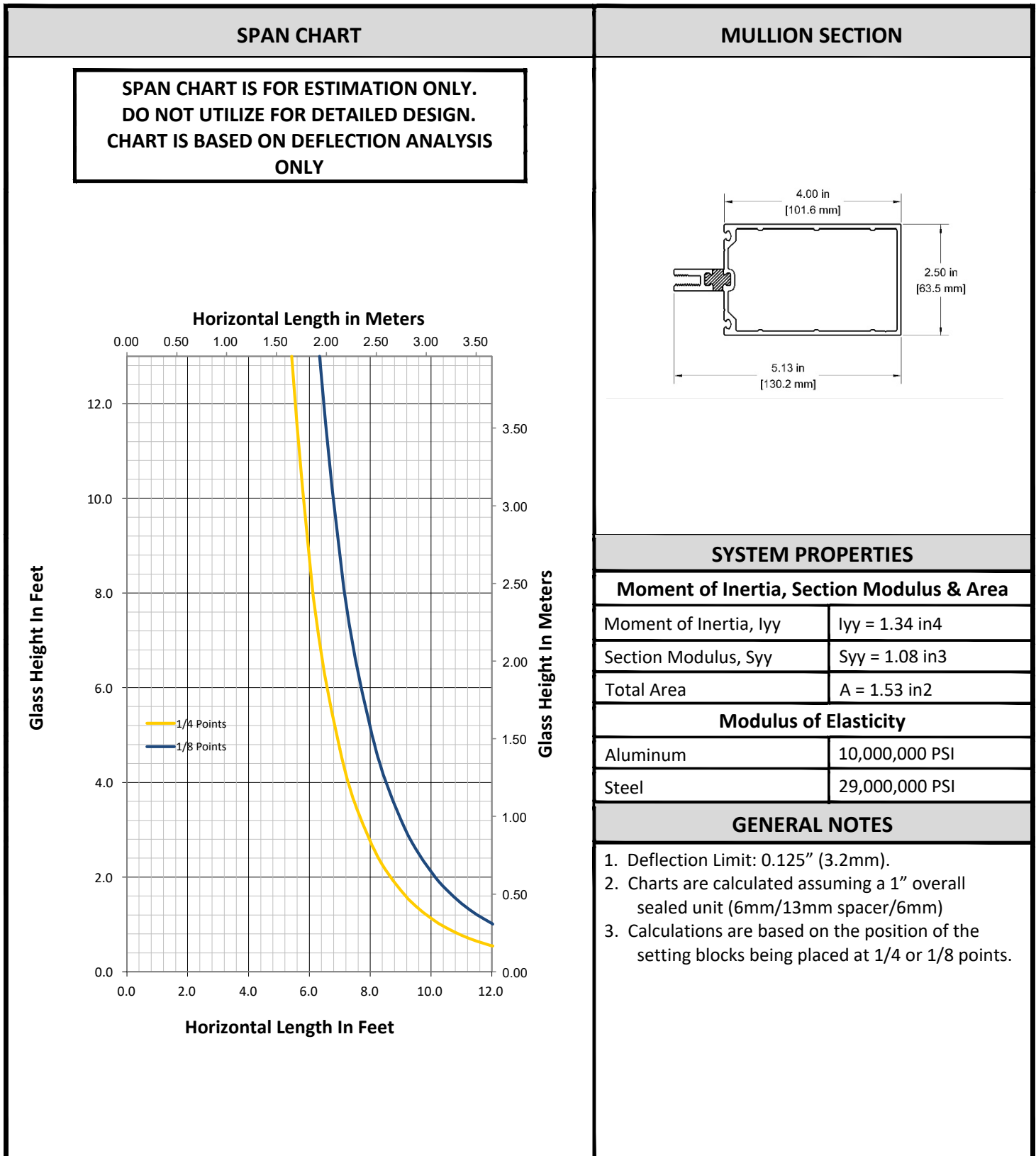

WIND LOAD CHART FOR 2 1/2" x 4" SSG MULLION - PART # 2523

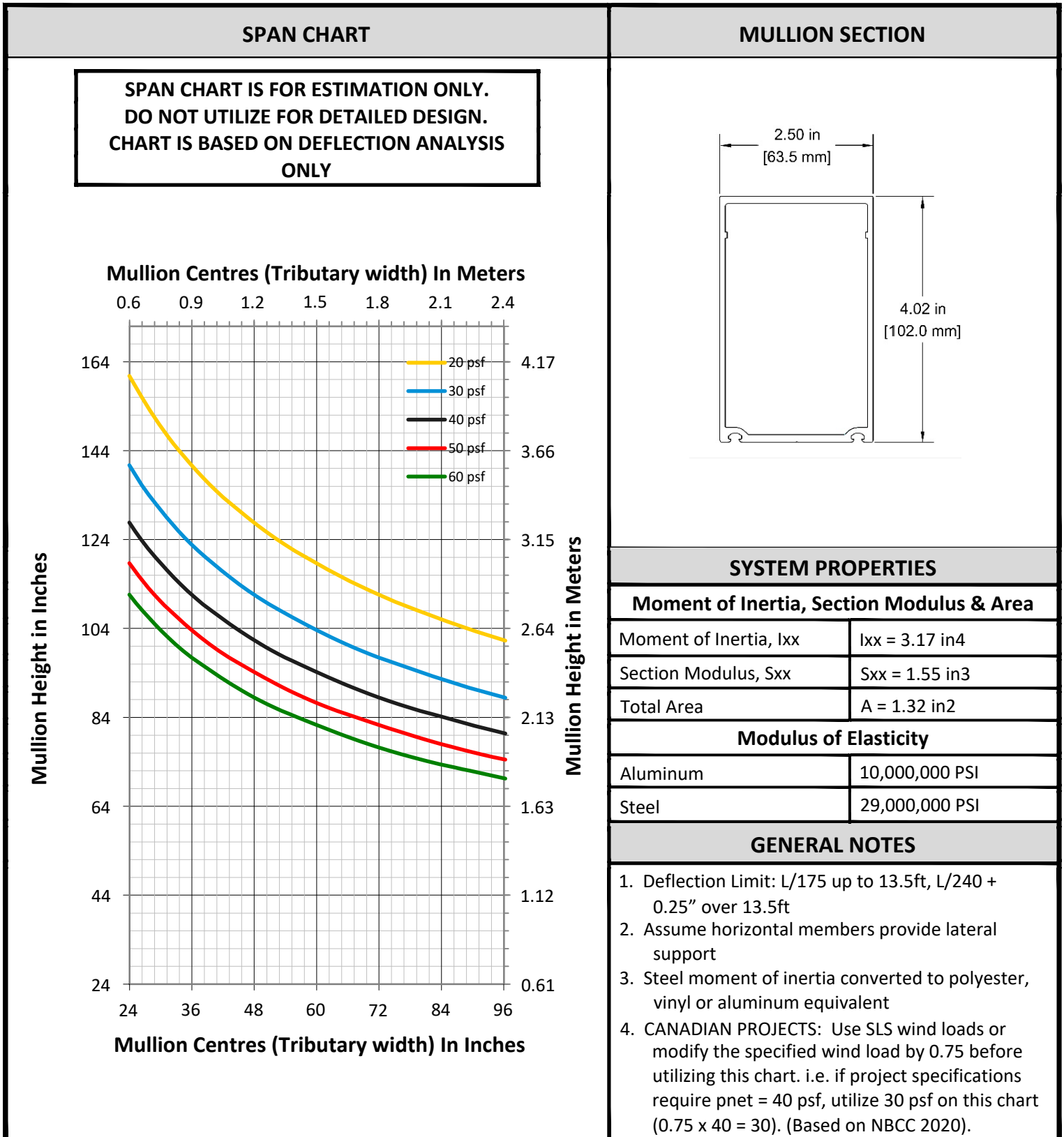

STEEL LOADED WIND LOAD CHART FOR 2 1/2" x 4" SSG MULLION - PART # 2523

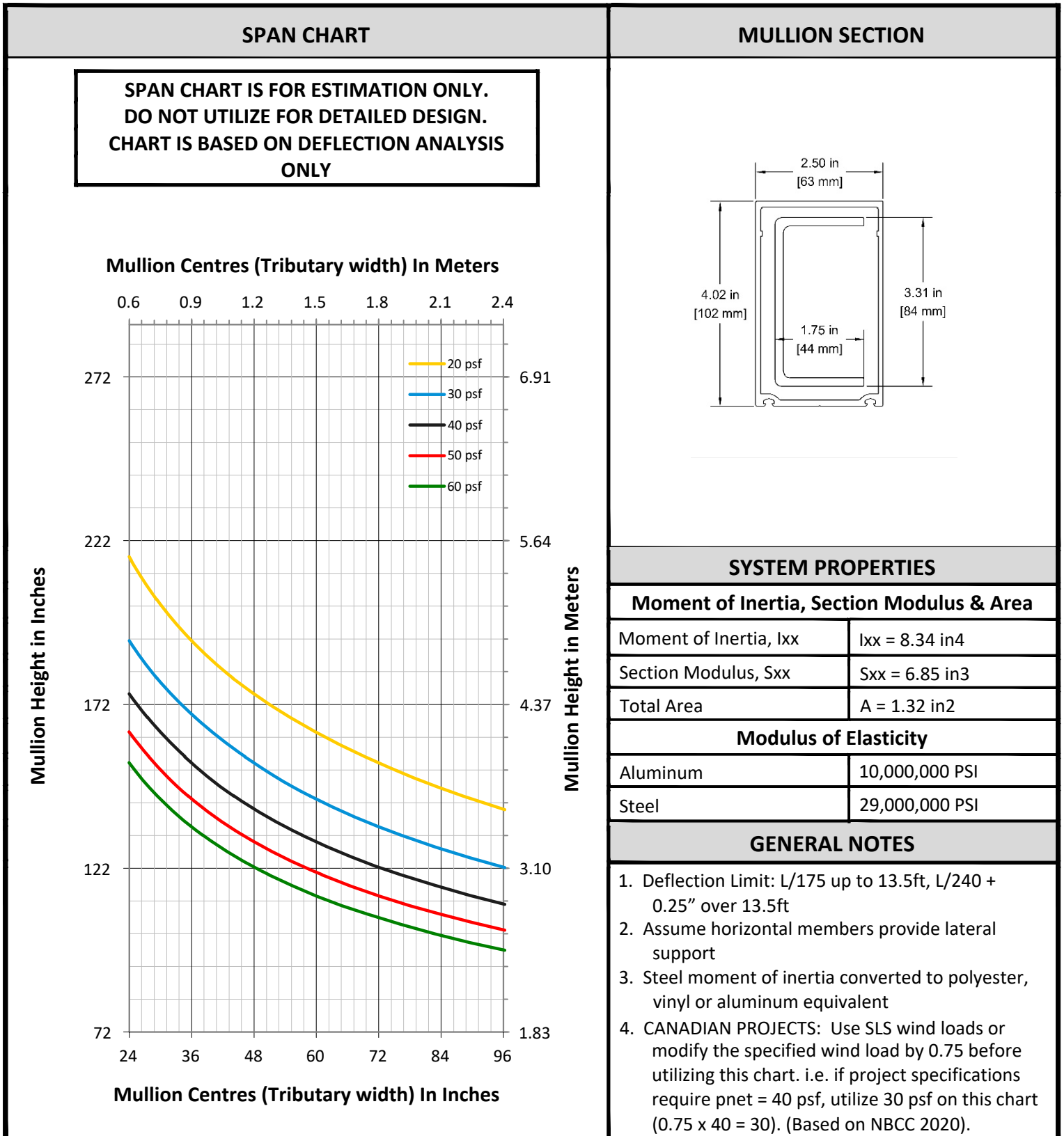

DEAD LOAD CHART FOR 2 1/2" x 4" SSG MULLION - PART # 2523

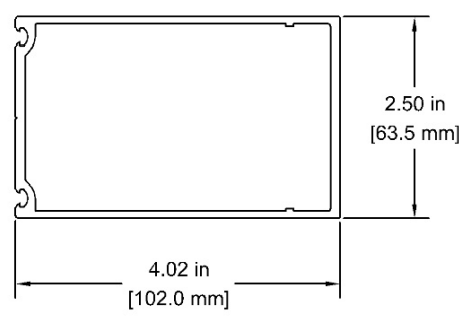
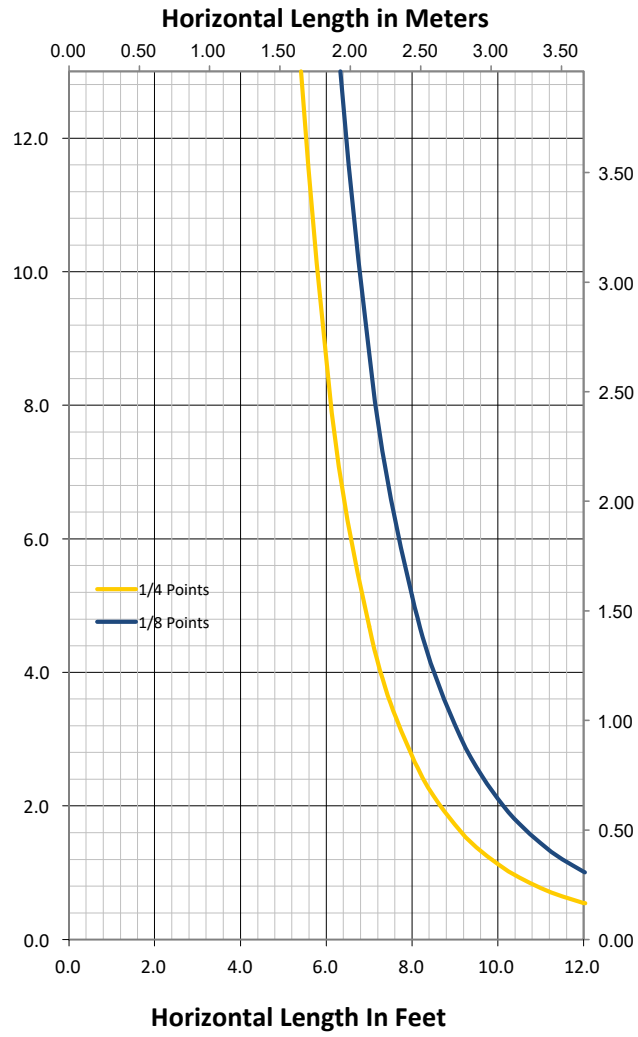
SPAN CHART	MULLION SECTION																				
<p>SPAN CHART IS FOR ESTIMATION ONLY. DO NOT UTILIZE FOR DETAILED DESIGN. CHART IS BASED ON DEFLECTION ANALYSIS ONLY</p>																					
	<table border="1" style="width: 100%; border-collapse: collapse;"> <thead> <tr style="background-color: #cccccc;"> <th colspan="2" style="text-align: center;">SYSTEM PROPERTIES</th> </tr> </thead> <tbody> <tr> <th colspan="2" style="text-align: center;">Moment of Inertia, Section Modulus & Area</th> </tr> <tr> <td style="text-align: left;">Moment of Inertia, I_{yy}</td> <td style="text-align: right;">$I_{yy} = 1.34 \text{ in}^4$</td> </tr> <tr> <td style="text-align: left;">Section Modulus, S_{yy}</td> <td style="text-align: right;">$S_{yy} = 1.07 \text{ in}^3$</td> </tr> <tr> <td style="text-align: left;">Total Area</td> <td style="text-align: right;">$A = 1.32 \text{ in}^2$</td> </tr> <tr> <th colspan="2" style="text-align: center;">Modulus of Elasticity</th> </tr> <tr> <td style="text-align: left;">Aluminum</td> <td style="text-align: right;">10,000,000 PSI</td> </tr> <tr> <td style="text-align: left;">Steel</td> <td style="text-align: right;">29,000,000 PSI</td> </tr> <tr> <th colspan="2" style="text-align: center;">GENERAL NOTES</th> </tr> <tr> <td colspan="2"> <ol style="list-style-type: none"> 1. Deflection Limit: 0.125" (3.2mm). 2. Charts are calculated assuming a 1" overall sealed unit (6mm/13mm spacer/6mm) 3. Calculations are based on the position of the setting blocks being placed at 1/4 or 1/8 points. </td> </tr> </tbody> </table>	SYSTEM PROPERTIES		Moment of Inertia, Section Modulus & Area		Moment of Inertia, I_{yy}	$I_{yy} = 1.34 \text{ in}^4$	Section Modulus, S_{yy}	$S_{yy} = 1.07 \text{ in}^3$	Total Area	$A = 1.32 \text{ in}^2$	Modulus of Elasticity		Aluminum	10,000,000 PSI	Steel	29,000,000 PSI	GENERAL NOTES		<ol style="list-style-type: none"> 1. Deflection Limit: 0.125" (3.2mm). 2. Charts are calculated assuming a 1" overall sealed unit (6mm/13mm spacer/6mm) 3. Calculations are based on the position of the setting blocks being placed at 1/4 or 1/8 points. 	
SYSTEM PROPERTIES																					
Moment of Inertia, Section Modulus & Area																					
Moment of Inertia, I_{yy}	$I_{yy} = 1.34 \text{ in}^4$																				
Section Modulus, S_{yy}	$S_{yy} = 1.07 \text{ in}^3$																				
Total Area	$A = 1.32 \text{ in}^2$																				
Modulus of Elasticity																					
Aluminum	10,000,000 PSI																				
Steel	29,000,000 PSI																				
GENERAL NOTES																					
<ol style="list-style-type: none"> 1. Deflection Limit: 0.125" (3.2mm). 2. Charts are calculated assuming a 1" overall sealed unit (6mm/13mm spacer/6mm) 3. Calculations are based on the position of the setting blocks being placed at 1/4 or 1/8 points. 																					

WIND LOAD CHART FOR 2 1/2" x 5 1/4" MULLION - PART # 2504T

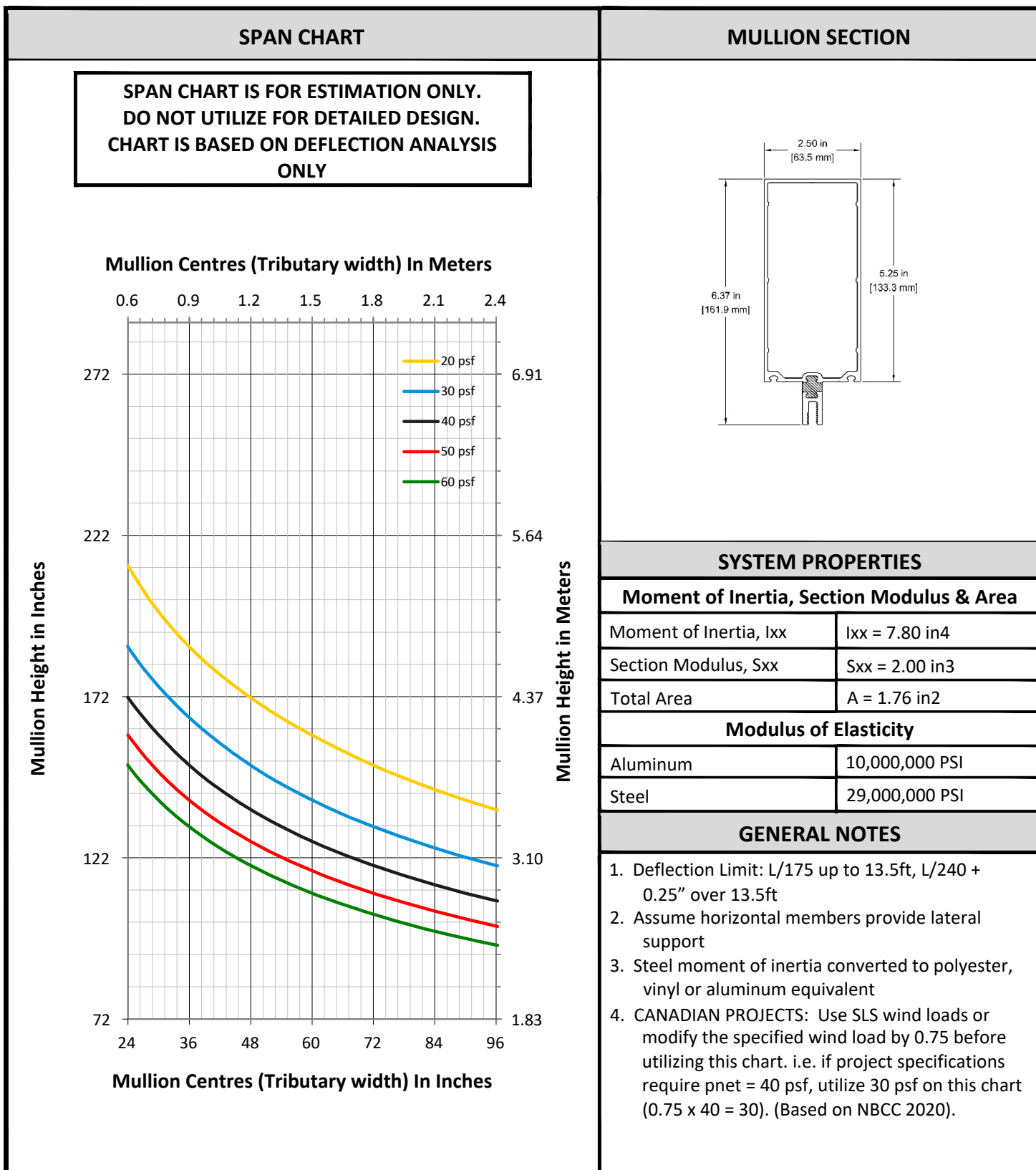

STEEL LOADED WIND LOAD CHART FOR 2 1/2" x 5 1/4" T/B MULLION - PART # 2504T

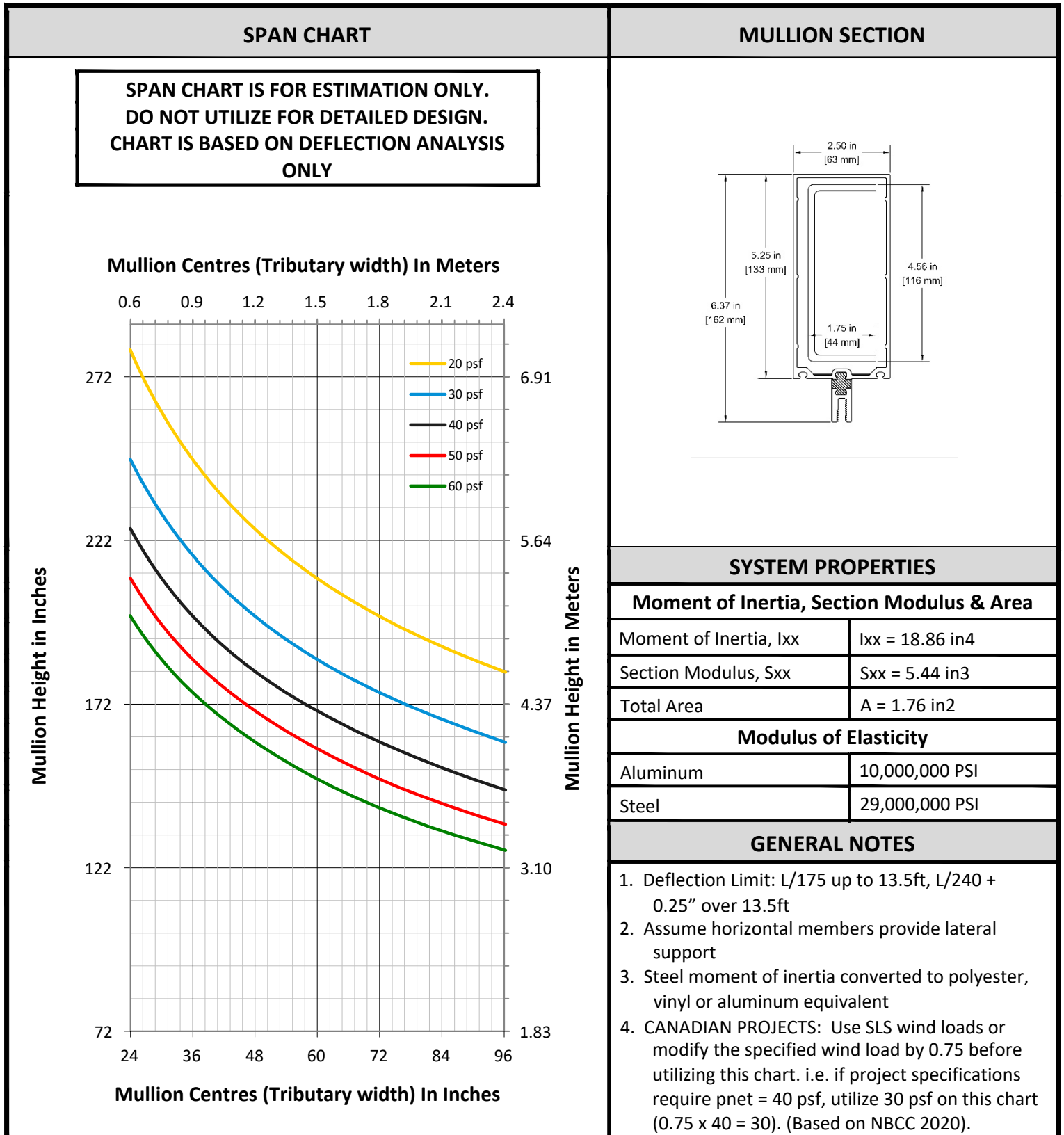

DEAD LOAD CHART FOR 2 1/2" x 5 1/4" T/B MULLION - PART # 2504T

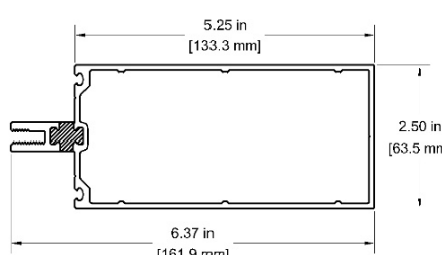
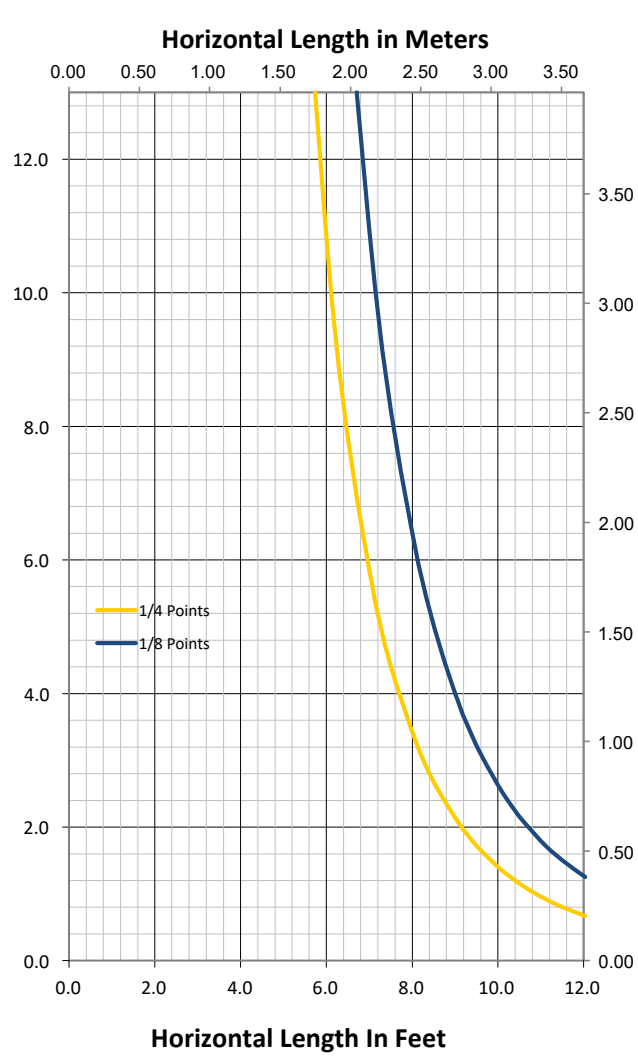
SPAN CHART	MULLION SECTION																				
<p>SPAN CHART IS FOR ESTIMATION ONLY. DO NOT UTILIZE FOR DETAILED DESIGN. CHART IS BASED ON DEFLECTION ANALYSIS ONLY</p>																					
 <p>Horizontal Length in Meters</p> <p>Glass Height In Feet</p> <p>Glass Height In Meters</p> <p>Horizontal Length In Feet</p> <p>— 1/4 Points — 1/8 Points</p>	<table border="1" style="width: 100%; border-collapse: collapse;"> <thead> <tr style="background-color: #cccccc;"> <th colspan="2" style="text-align: center;">SYSTEM PROPERTIES</th> </tr> </thead> <tbody> <tr> <th colspan="2" style="text-align: center;">Moment of Inertia, Section Modulus & Area</th> </tr> <tr> <td>Moment of Inertia, I_{yy}</td> <td>I_{yy} = 1.67 in⁴</td> </tr> <tr> <td>Section Modulus, S_{yy}</td> <td>S_{yy} = 1.33 in³</td> </tr> <tr> <td>Total Area</td> <td>A = 1.76 in²</td> </tr> <tr> <th colspan="2" style="text-align: center;">Modulus of Elasticity</th> </tr> <tr> <td>Aluminum</td> <td>10,000,000 PSI</td> </tr> <tr> <td>Steel</td> <td>29,000,000 PSI</td> </tr> <tr style="background-color: #cccccc;"> <th colspan="2" style="text-align: center;">GENERAL NOTES</th> </tr> <tr> <td colspan="2"> <ol style="list-style-type: none"> 1. Deflection Limit: 0.125" (3.2mm). 2. Charts are calculated assuming a 1" overall sealed unit (6mm/13mm spacer/6mm) 3. Calculations are based on the position of the setting blocks being placed at 1/4 or 1/8 points. </td> </tr> </tbody> </table>	SYSTEM PROPERTIES		Moment of Inertia, Section Modulus & Area		Moment of Inertia, I _{yy}	I _{yy} = 1.67 in ⁴	Section Modulus, S _{yy}	S _{yy} = 1.33 in ³	Total Area	A = 1.76 in ²	Modulus of Elasticity		Aluminum	10,000,000 PSI	Steel	29,000,000 PSI	GENERAL NOTES		<ol style="list-style-type: none"> 1. Deflection Limit: 0.125" (3.2mm). 2. Charts are calculated assuming a 1" overall sealed unit (6mm/13mm spacer/6mm) 3. Calculations are based on the position of the setting blocks being placed at 1/4 or 1/8 points. 	
SYSTEM PROPERTIES																					
Moment of Inertia, Section Modulus & Area																					
Moment of Inertia, I _{yy}	I _{yy} = 1.67 in ⁴																				
Section Modulus, S _{yy}	S _{yy} = 1.33 in ³																				
Total Area	A = 1.76 in ²																				
Modulus of Elasticity																					
Aluminum	10,000,000 PSI																				
Steel	29,000,000 PSI																				
GENERAL NOTES																					
<ol style="list-style-type: none"> 1. Deflection Limit: 0.125" (3.2mm). 2. Charts are calculated assuming a 1" overall sealed unit (6mm/13mm spacer/6mm) 3. Calculations are based on the position of the setting blocks being placed at 1/4 or 1/8 points. 																					

WIND LOAD CHART FOR 2 1/2" x 5 1/4" SSG MULLION - PART # 2555

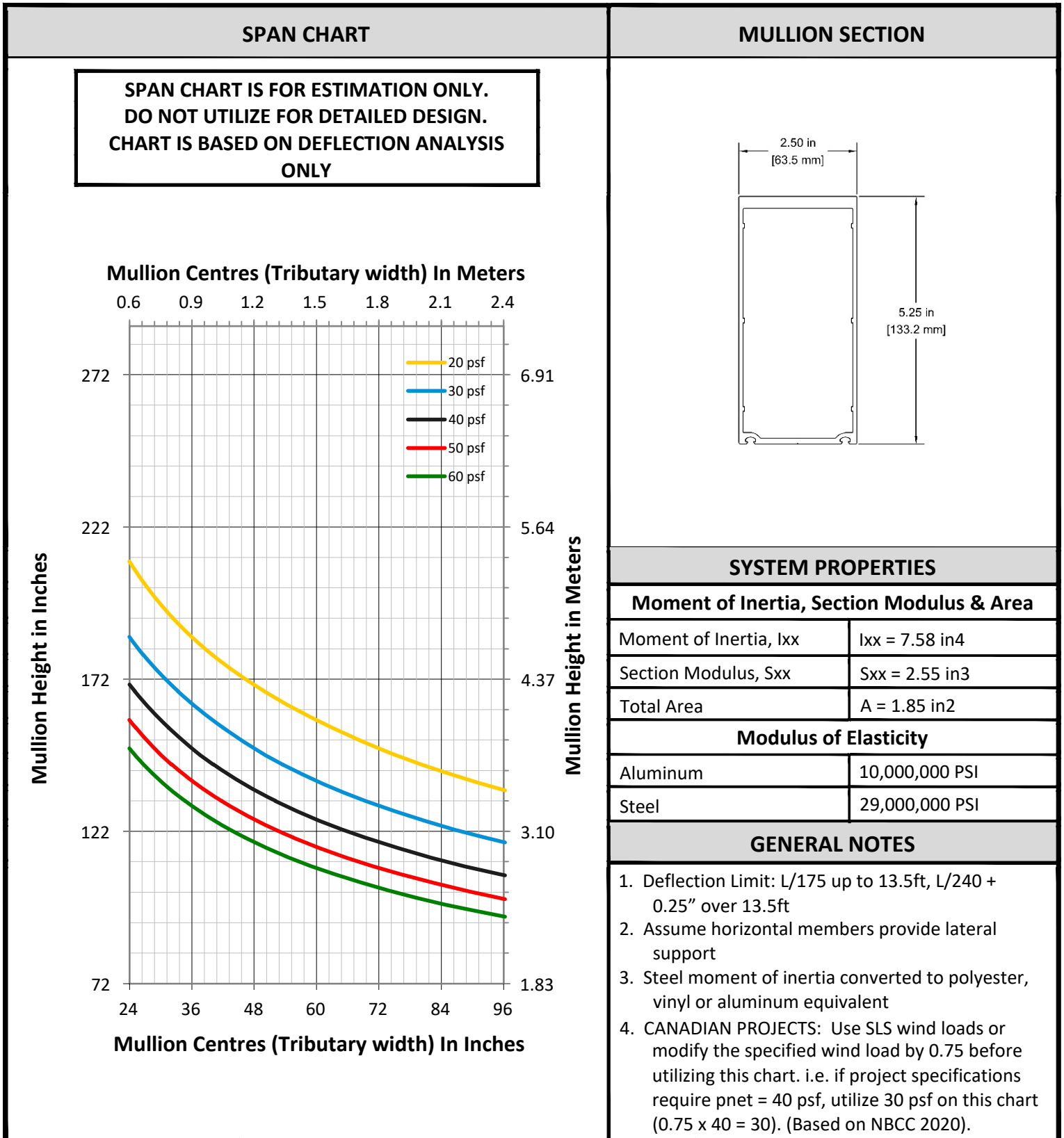

STEEL LOADED WIND LOAD CHART FOR 2 1/2" x 5 1/4" SSG MULLION - PART # 2555

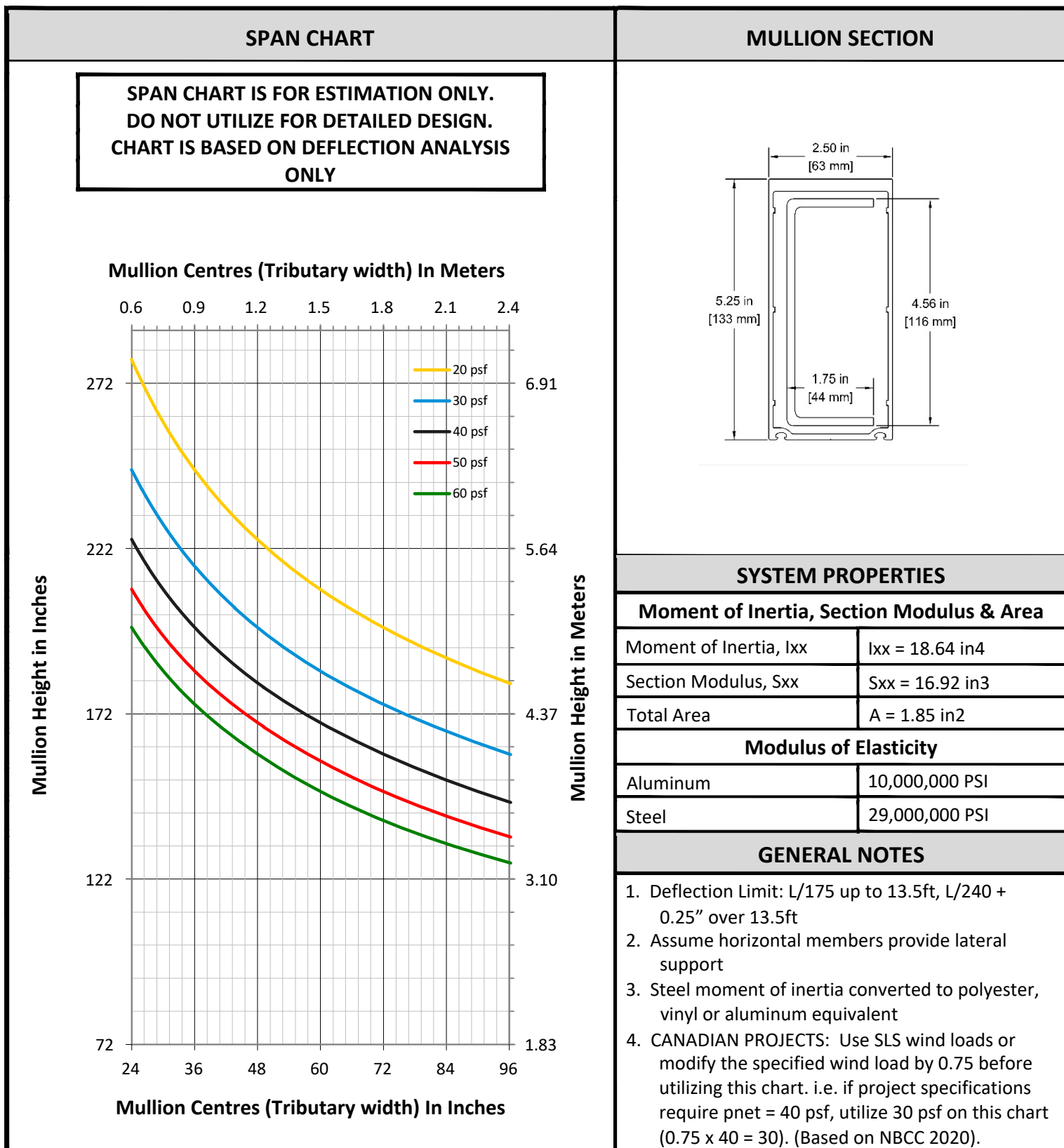

DEAD LOAD CHART FOR 2 1/2" x 5 1/4" SSG MULLION - PART # 2555

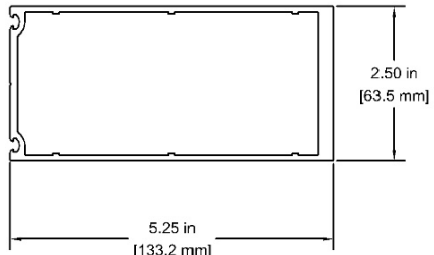
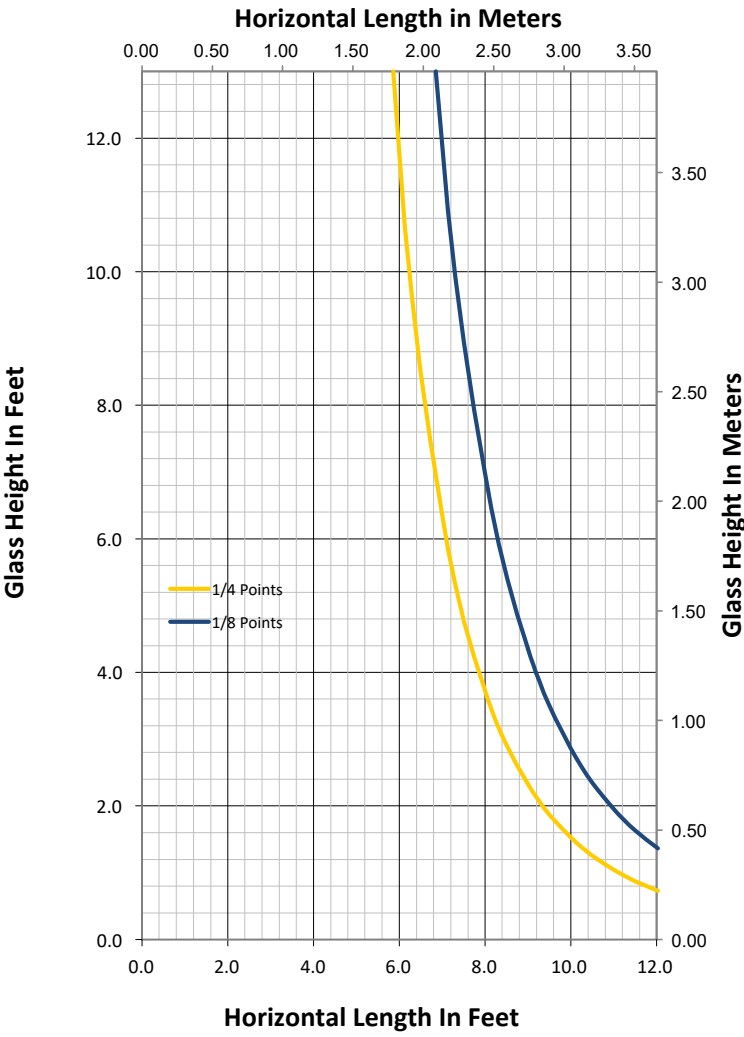
SPAN CHART	MULLION SECTION																				
<p>SPAN CHART IS FOR ESTIMATION ONLY. DO NOT UTILIZE FOR DETAILED DESIGN. CHART IS BASED ON DEFLECTION ANALYSIS ONLY</p>																					
	<table border="1" style="width: 100%; border-collapse: collapse;"> <thead> <tr style="background-color: #cccccc;"> <th colspan="2" style="text-align: center;">SYSTEM PROPERTIES</th> </tr> </thead> <tbody> <tr> <th colspan="2" style="text-align: center;">Moment of Inertia, Section Modulus & Area</th> </tr> <tr> <td>Moment of Inertia, I_{yy}</td> <td>$I_{yy} = 1.81 \text{ in}^4$</td> </tr> <tr> <td>Section Modulus, S_{yy}</td> <td>$S_{yy} = 1.45 \text{ in}^3$</td> </tr> <tr> <td>Total Area</td> <td>$A = 1.85 \text{ in}^2$</td> </tr> <tr> <th colspan="2" style="text-align: center;">Modulus of Elasticity</th> </tr> <tr> <td>Aluminum</td> <td>10,000,000 PSI</td> </tr> <tr> <td>Steel</td> <td>29,000,000 PSI</td> </tr> <tr> <th colspan="2" style="text-align: center;">GENERAL NOTES</th> </tr> <tr> <td colspan="2"> <ol style="list-style-type: none"> 1. Deflection Limit: 0.125" (3.2mm). 2. Charts are calculated assuming a 1" overall sealed unit (6mm/13mm spacer/6mm) 3. Calculations are based on the position of the setting blocks being placed at 1/4 or 1/8 points. </td> </tr> </tbody> </table>	SYSTEM PROPERTIES		Moment of Inertia, Section Modulus & Area		Moment of Inertia, I_{yy}	$I_{yy} = 1.81 \text{ in}^4$	Section Modulus, S_{yy}	$S_{yy} = 1.45 \text{ in}^3$	Total Area	$A = 1.85 \text{ in}^2$	Modulus of Elasticity		Aluminum	10,000,000 PSI	Steel	29,000,000 PSI	GENERAL NOTES		<ol style="list-style-type: none"> 1. Deflection Limit: 0.125" (3.2mm). 2. Charts are calculated assuming a 1" overall sealed unit (6mm/13mm spacer/6mm) 3. Calculations are based on the position of the setting blocks being placed at 1/4 or 1/8 points. 	
SYSTEM PROPERTIES																					
Moment of Inertia, Section Modulus & Area																					
Moment of Inertia, I_{yy}	$I_{yy} = 1.81 \text{ in}^4$																				
Section Modulus, S_{yy}	$S_{yy} = 1.45 \text{ in}^3$																				
Total Area	$A = 1.85 \text{ in}^2$																				
Modulus of Elasticity																					
Aluminum	10,000,000 PSI																				
Steel	29,000,000 PSI																				
GENERAL NOTES																					
<ol style="list-style-type: none"> 1. Deflection Limit: 0.125" (3.2mm). 2. Charts are calculated assuming a 1" overall sealed unit (6mm/13mm spacer/6mm) 3. Calculations are based on the position of the setting blocks being placed at 1/4 or 1/8 points. 																					

WIND LOAD CHART FOR 2 1/2" x 8" T/B MULLION - PART # 2580T

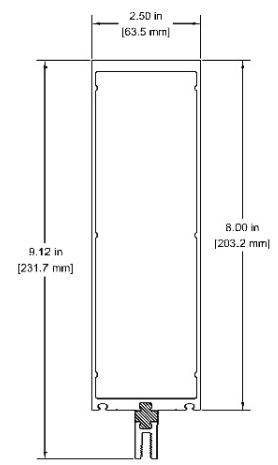
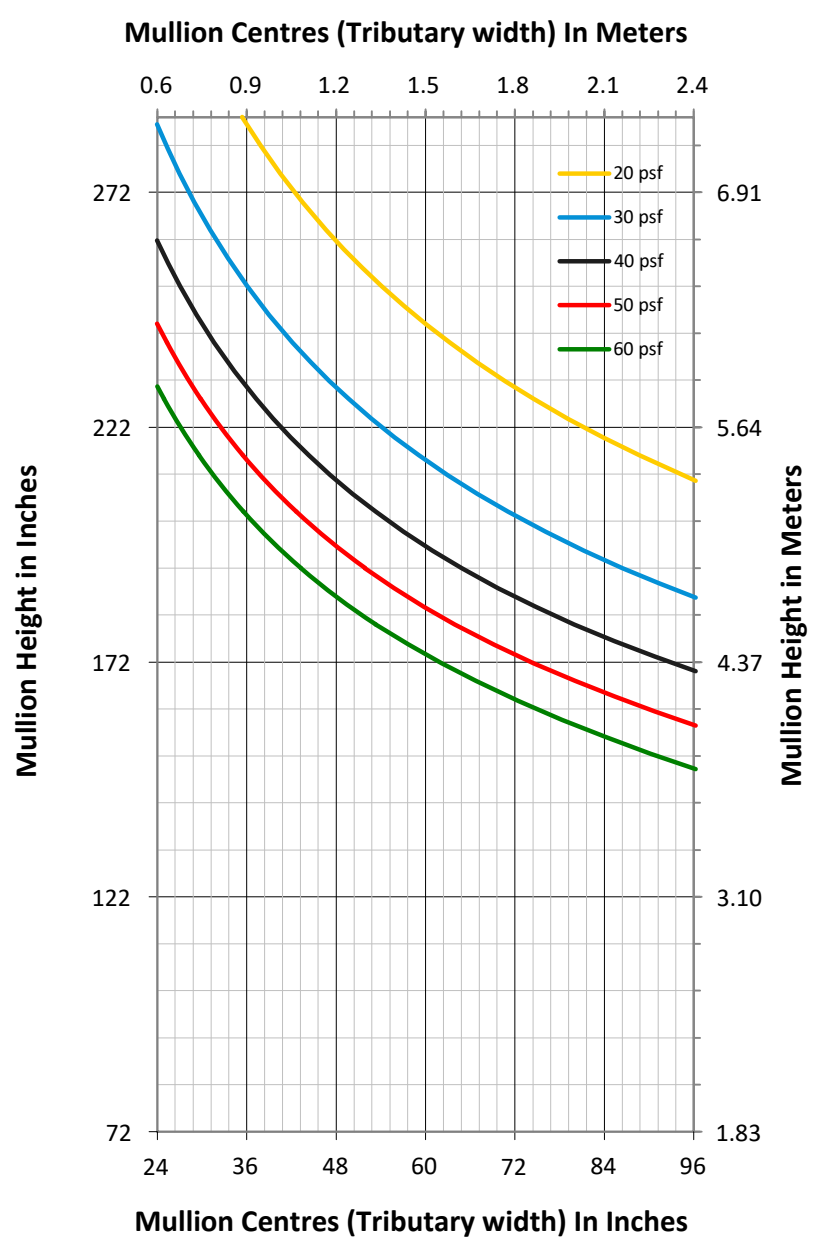
SPAN CHART	MULLION SECTION																				
<p>SPAN CHART IS FOR ESTIMATION ONLY. DO NOT UTILIZE FOR DETAILED DESIGN. CHART IS BASED ON DEFLECTION ANALYSIS ONLY</p>																					
<p style="text-align: center;">Mullion Centres (Tributary width) In Meters</p> <p style="text-align: center;">0.6 0.9 1.2 1.5 1.8 2.1 2.4</p>  <p style="text-align: center;">Mullion Centres (Tributary width) In Inches</p> <p style="text-align: center;">24 36 48 60 72 84 96</p>	<table border="1" style="width: 100%; border-collapse: collapse;"> <thead> <tr style="background-color: #cccccc;"> <th colspan="2" style="text-align: center;">SYSTEM PROPERTIES</th> </tr> </thead> <tbody> <tr> <th colspan="2" style="text-align: center;">Moment of Inertia, Section Modulus & Area</th> </tr> <tr> <td style="width: 50%;">Moment of Inertia, I_{xx}</td> <td>I_{xx} = 30.35 in⁴</td> </tr> <tr> <td>Section Modulus, S_{xx}</td> <td>S_{xx} = 5.98 in³</td> </tr> <tr> <td>Total Area</td> <td>A = 2.87 in²</td> </tr> <tr> <th colspan="2" style="text-align: center;">Modulus of Elasticity</th> </tr> <tr> <td>Aluminum</td> <td>10,000,000 PSI</td> </tr> <tr> <td>Steel</td> <td>29,000,000 PSI</td> </tr> <tr> <th colspan="2" style="text-align: center;">GENERAL NOTES</th> </tr> <tr> <td colspan="2"> <ol style="list-style-type: none"> 1. Deflection Limit: L/175 up to 13.5ft, L/240 + 0.25" over 13.5ft 2. Assume horizontal members provide lateral support 3. Steel moment of inertia converted to polyester, vinyl or aluminum equivalent 4. CANADIAN PROJECTS: Use SLS wind loads or modify the specified wind load by 0.75 before utilizing this chart. i.e. if project specifications require pnet = 40 psf, utilize 30 psf on this chart (0.75 x 40 = 30). (Based on NBCC 2020). </td> </tr> </tbody> </table>	SYSTEM PROPERTIES		Moment of Inertia, Section Modulus & Area		Moment of Inertia, I _{xx}	I _{xx} = 30.35 in ⁴	Section Modulus, S _{xx}	S _{xx} = 5.98 in ³	Total Area	A = 2.87 in ²	Modulus of Elasticity		Aluminum	10,000,000 PSI	Steel	29,000,000 PSI	GENERAL NOTES		<ol style="list-style-type: none"> 1. Deflection Limit: L/175 up to 13.5ft, L/240 + 0.25" over 13.5ft 2. Assume horizontal members provide lateral support 3. Steel moment of inertia converted to polyester, vinyl or aluminum equivalent 4. CANADIAN PROJECTS: Use SLS wind loads or modify the specified wind load by 0.75 before utilizing this chart. i.e. if project specifications require pnet = 40 psf, utilize 30 psf on this chart (0.75 x 40 = 30). (Based on NBCC 2020). 	
SYSTEM PROPERTIES																					
Moment of Inertia, Section Modulus & Area																					
Moment of Inertia, I _{xx}	I _{xx} = 30.35 in ⁴																				
Section Modulus, S _{xx}	S _{xx} = 5.98 in ³																				
Total Area	A = 2.87 in ²																				
Modulus of Elasticity																					
Aluminum	10,000,000 PSI																				
Steel	29,000,000 PSI																				
GENERAL NOTES																					
<ol style="list-style-type: none"> 1. Deflection Limit: L/175 up to 13.5ft, L/240 + 0.25" over 13.5ft 2. Assume horizontal members provide lateral support 3. Steel moment of inertia converted to polyester, vinyl or aluminum equivalent 4. CANADIAN PROJECTS: Use SLS wind loads or modify the specified wind load by 0.75 before utilizing this chart. i.e. if project specifications require pnet = 40 psf, utilize 30 psf on this chart (0.75 x 40 = 30). (Based on NBCC 2020). 																					

STEEL LOADED WIND LOAD CHART FOR 2 1/2" x 8" T/B MULLION - PART # 2580T

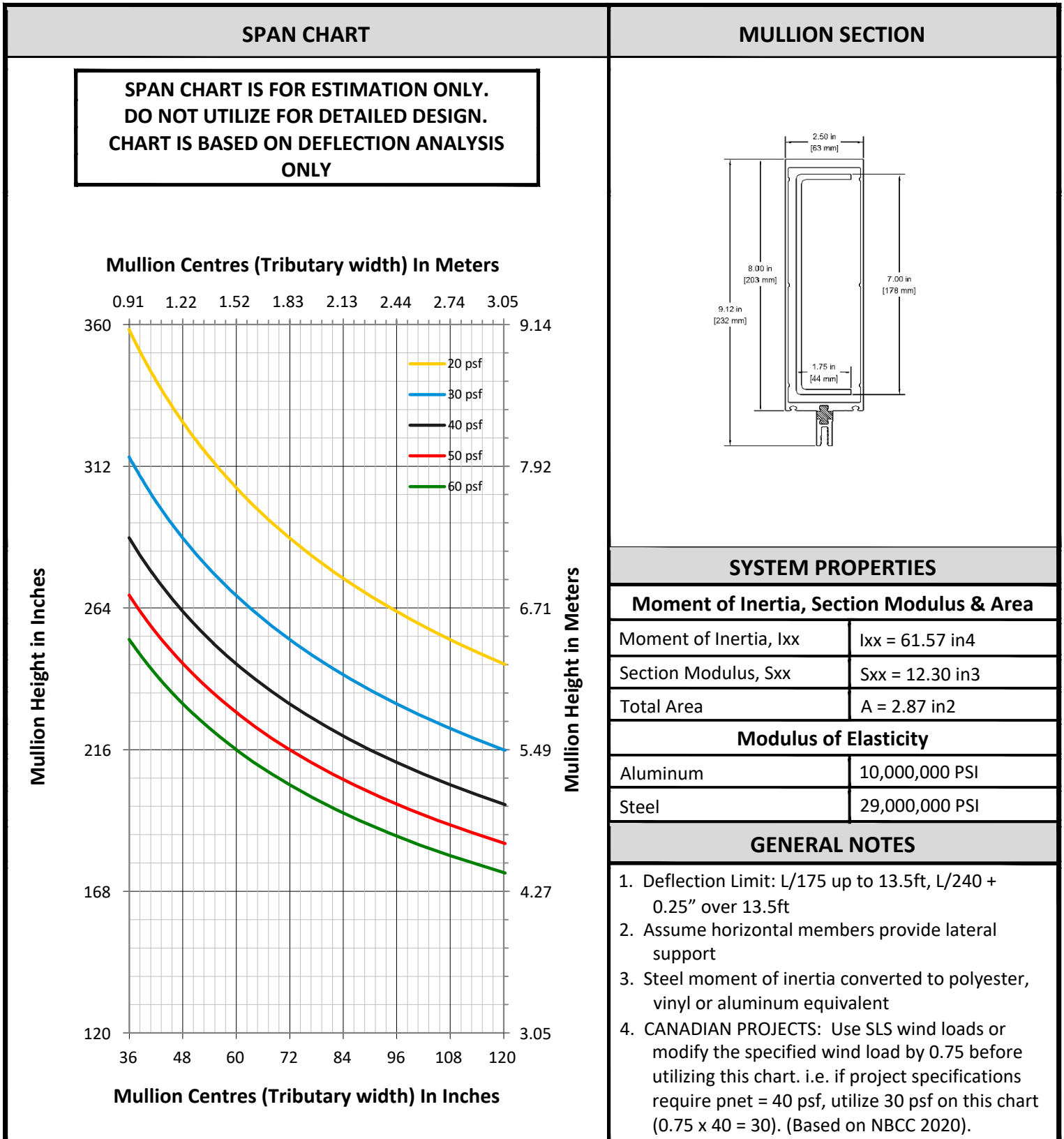

DEAD LOAD CHART FOR 2 1/2" x 8" T/B MULLION - PART # 2580T

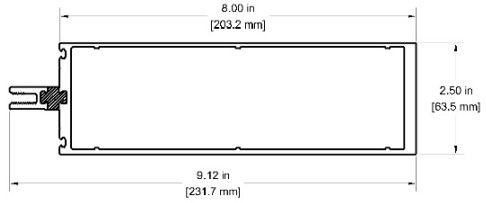
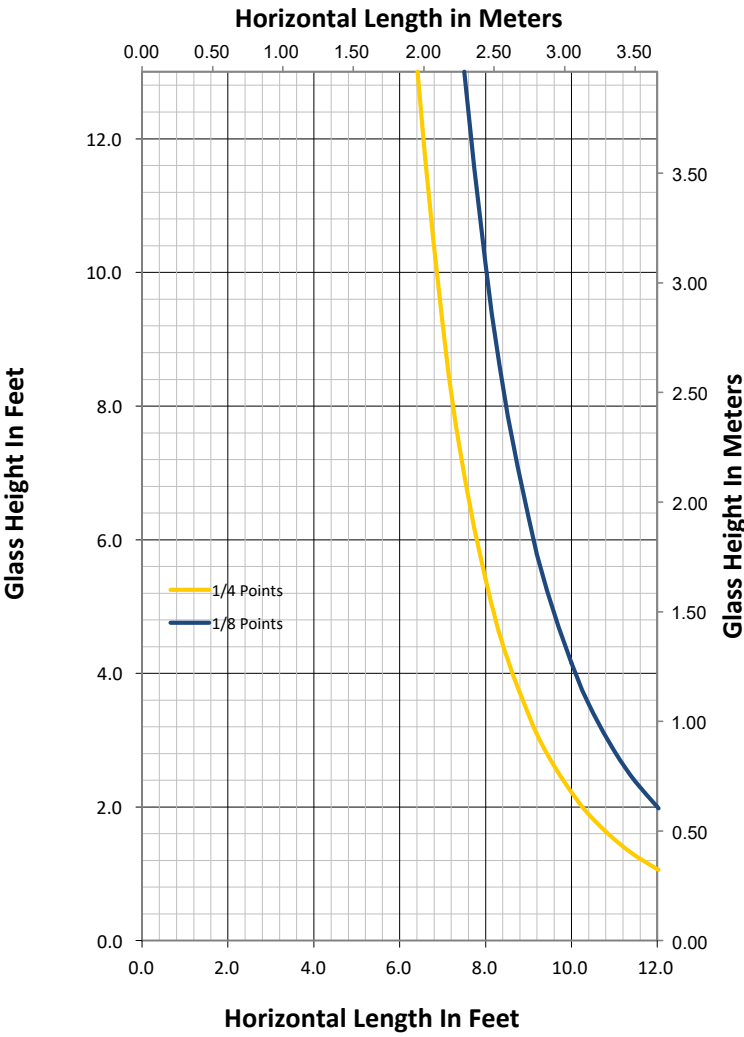
SPAN CHART	MULLION SECTION																				
<p>SPAN CHART IS FOR ESTIMATION ONLY. DO NOT UTILIZE FOR DETAILED DESIGN. CHART IS BASED ON DEFLECTION ANALYSIS ONLY</p>																					
	<table border="1" style="width: 100%; border-collapse: collapse;"> <thead> <tr style="background-color: #cccccc;"> <th colspan="2" style="text-align: center;">SYSTEM PROPERTIES</th> </tr> </thead> <tbody> <tr> <th colspan="2" style="text-align: center;">Moment of Inertia, Section Modulus & Area</th> </tr> <tr> <td style="text-align: left;">Moment of Inertia, I_{yy}</td> <td style="text-align: right;">$I_{yy} = 2.64 \text{ in}^4$</td> </tr> <tr> <td style="text-align: left;">Section Modulus, S_{yy}</td> <td style="text-align: right;">$S_{yy} = 2.10 \text{ in}^3$</td> </tr> <tr> <td style="text-align: left;">Total Area</td> <td style="text-align: right;">$A = 2.87 \text{ in}^2$</td> </tr> <tr> <th colspan="2" style="text-align: center;">Modulus of Elasticity</th> </tr> <tr> <td style="text-align: left;">Aluminum</td> <td style="text-align: right;">10,000,000 PSI</td> </tr> <tr> <td style="text-align: left;">Steel</td> <td style="text-align: right;">29,000,000 PSI</td> </tr> <tr> <th colspan="2" style="text-align: center;">GENERAL NOTES</th> </tr> <tr> <td colspan="2"> <ol style="list-style-type: none"> 1. Deflection Limit: 0.125" (3.2mm). 2. Charts are calculated assuming a 1" overall sealed unit (6mm/13mm spacer/6mm) 3. Calculations are based on the position of the setting blocks being placed at 1/4 or 1/8 points. </td> </tr> </tbody> </table>	SYSTEM PROPERTIES		Moment of Inertia, Section Modulus & Area		Moment of Inertia, I_{yy}	$I_{yy} = 2.64 \text{ in}^4$	Section Modulus, S_{yy}	$S_{yy} = 2.10 \text{ in}^3$	Total Area	$A = 2.87 \text{ in}^2$	Modulus of Elasticity		Aluminum	10,000,000 PSI	Steel	29,000,000 PSI	GENERAL NOTES		<ol style="list-style-type: none"> 1. Deflection Limit: 0.125" (3.2mm). 2. Charts are calculated assuming a 1" overall sealed unit (6mm/13mm spacer/6mm) 3. Calculations are based on the position of the setting blocks being placed at 1/4 or 1/8 points. 	
SYSTEM PROPERTIES																					
Moment of Inertia, Section Modulus & Area																					
Moment of Inertia, I_{yy}	$I_{yy} = 2.64 \text{ in}^4$																				
Section Modulus, S_{yy}	$S_{yy} = 2.10 \text{ in}^3$																				
Total Area	$A = 2.87 \text{ in}^2$																				
Modulus of Elasticity																					
Aluminum	10,000,000 PSI																				
Steel	29,000,000 PSI																				
GENERAL NOTES																					
<ol style="list-style-type: none"> 1. Deflection Limit: 0.125" (3.2mm). 2. Charts are calculated assuming a 1" overall sealed unit (6mm/13mm spacer/6mm) 3. Calculations are based on the position of the setting blocks being placed at 1/4 or 1/8 points. 																					



**METRO
ALUMINUM**
Products Ltd.

2500THP SERIES
TRIPLE GLAZED - THERMALLY BROKEN
CURTAIN WALL & WINDOW SYSTEM
2 1/2" (63.5 mm) - FRAME

D

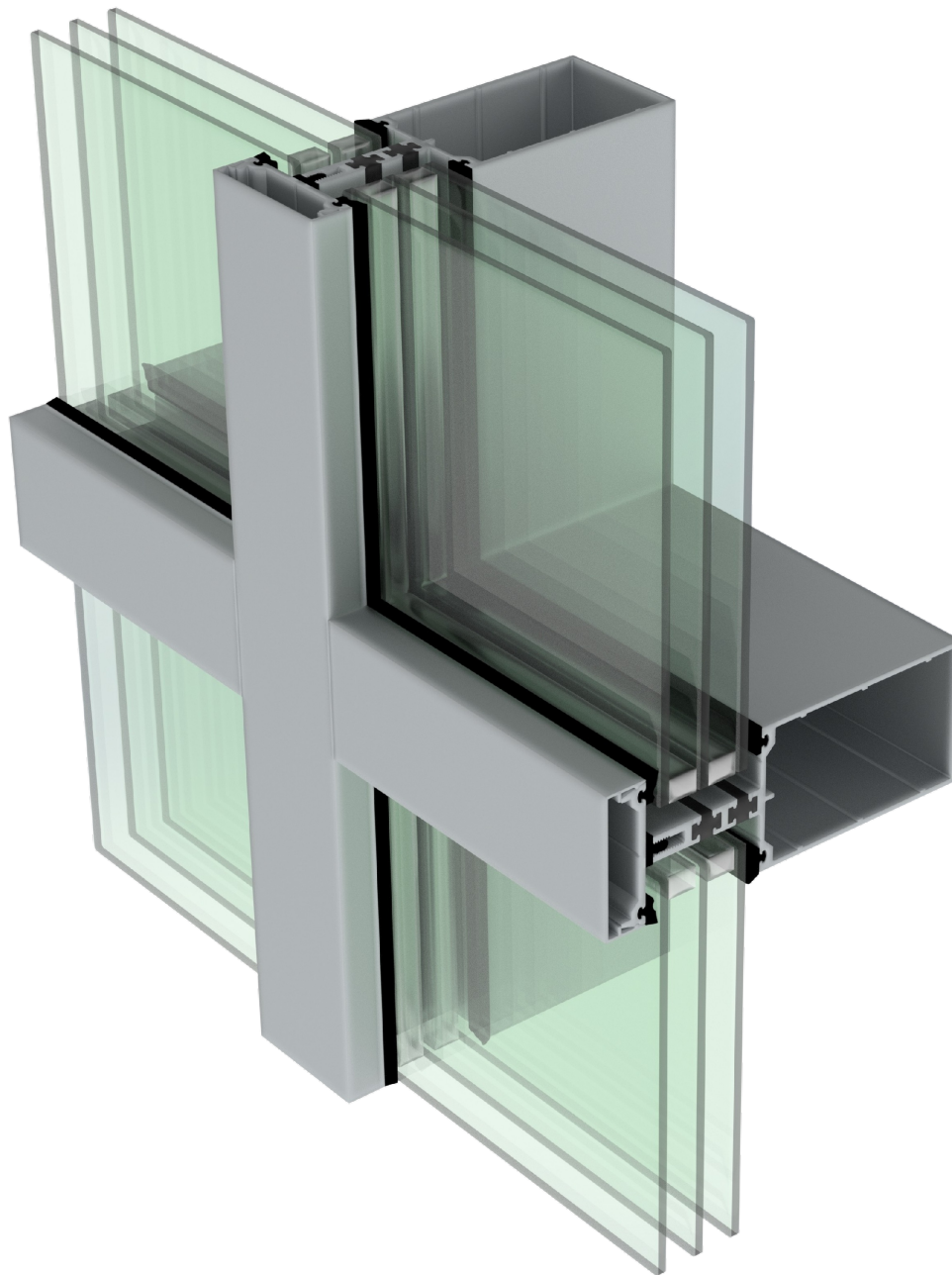



**METRO
ALUMINUM**
Products Ltd.

2500THP SERIES
TRIPLE GLAZED - THERMALLY BROKEN
CURTAIN WALL & WINDOW SYSTEM
2 1/2" (63.5 mm) - FRAME

**D
55**

BACK SECTIONS

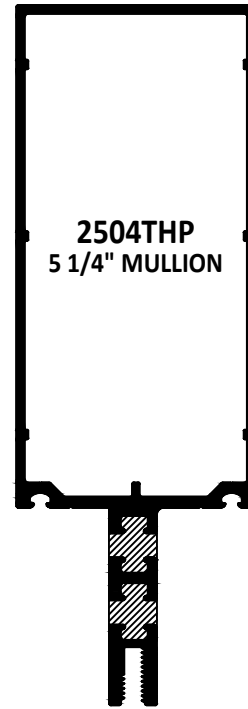
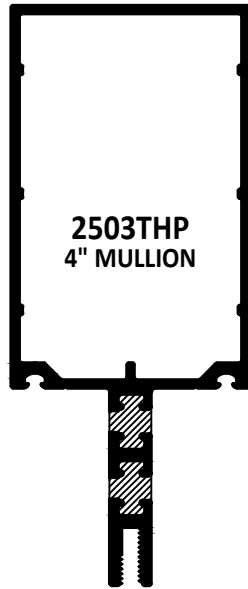

2505
PRESSURE PLATE



2505F
FIBRE GLASS PRESSURE PLATE



2506
3/4" CAP



2507
1 1/4" CAP

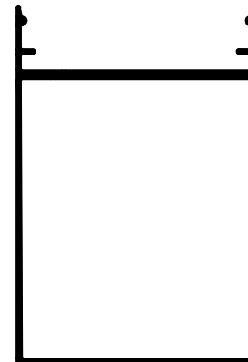

2508
3 3/4" CAP



**METRO
ALUMINUM**
Products Ltd.

2500THP SERIES
TRIPLE GLAZED - THERMALLY BROKEN
CURTAIN WALL & WINDOW SYSTEM
2 1/2" (63.5 mm) - FRAME

**D
56**

SSG COMPONENTS

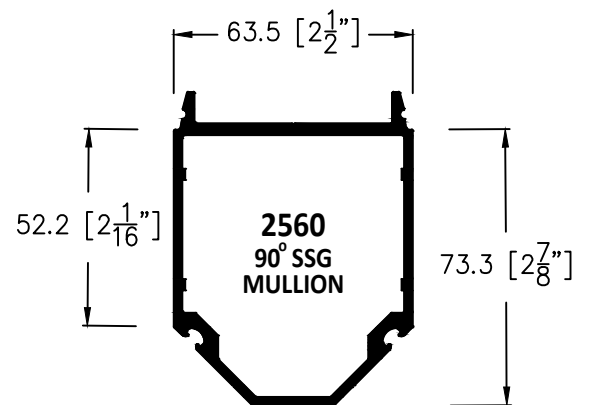
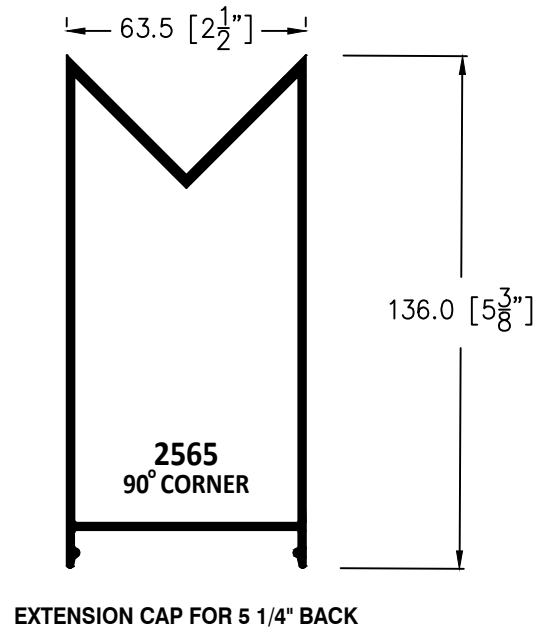
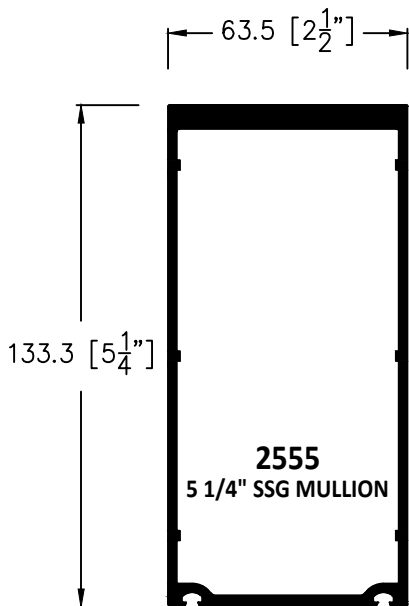
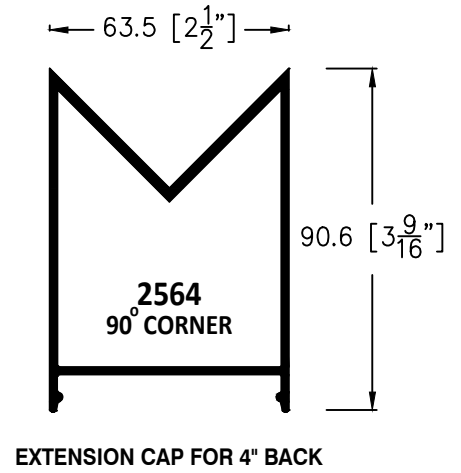
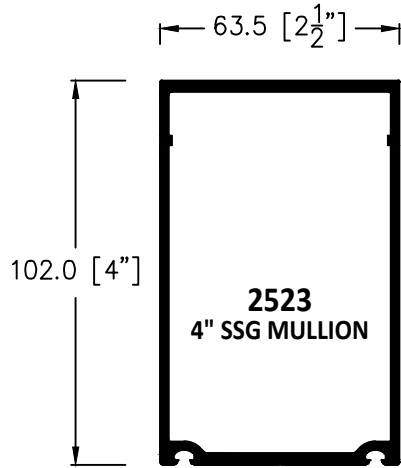



MISC. COMPONENTS



2410
THERMAL BREAK



2515-3
CORNER BLOCK



2460
SPONGE GASKET
(INTERIOR)



2450
DENSE GASKET
(EXTERIOR)

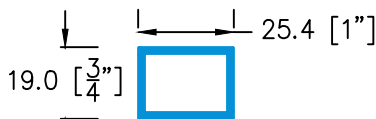

7501
PVC
ANTI-ROTATION

2435
DOOR
ADAPTER

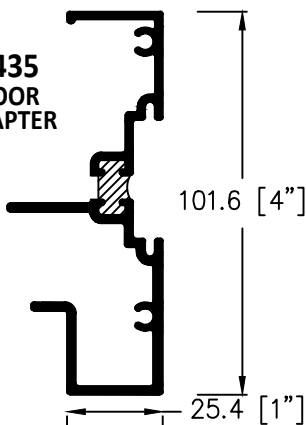

2520
SPIGOT

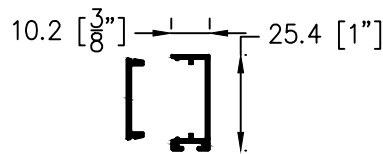

2417/2418
SURFACE APPLIED
DOOR STOP



20120T
DOOR STOP
FOR 2" DOORS



2430
BACK-PAN
ADAPTOR



2012T
DOOR STOP
FOR 1 3/4" DOORS



5102
1" X 2" PERIMETER ANGLE



5103
1" X 3" PERIMETER ANGLE

TYPICAL DETAILS

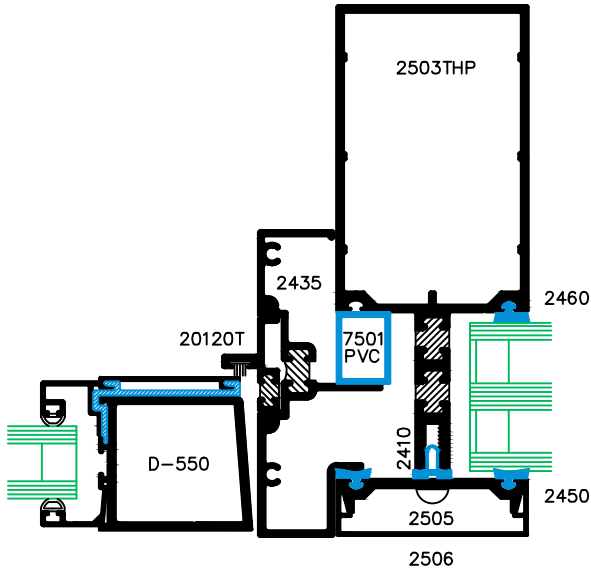

1a

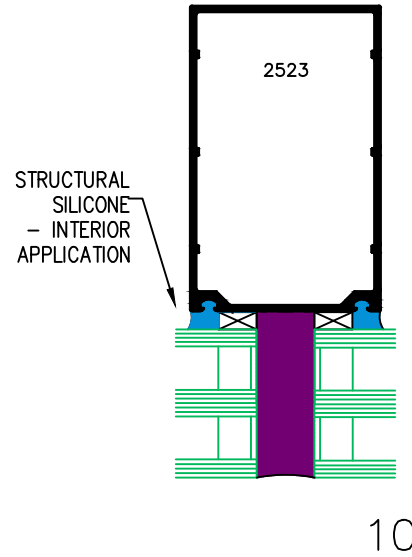

10

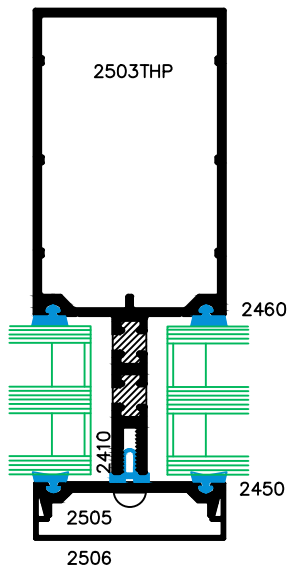

2

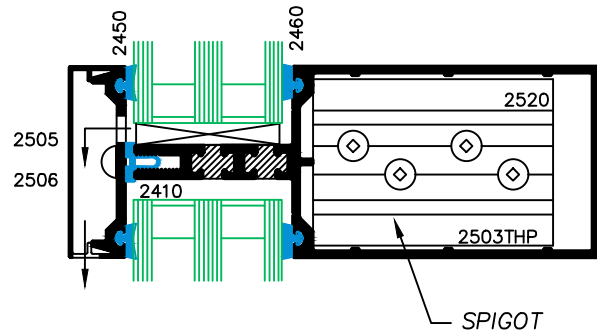

4



**METRO
ALUMINUM**
Products Ltd.

2500THP SERIES
TRIPLE GLAZED - THERMALLY BROKEN
CURTAIN WALL & WINDOW SYSTEM
2 1/2" (63.5 mm) - FRAME

**D
58A**

TYPICAL CURTAIN WALL VENT DETAILS

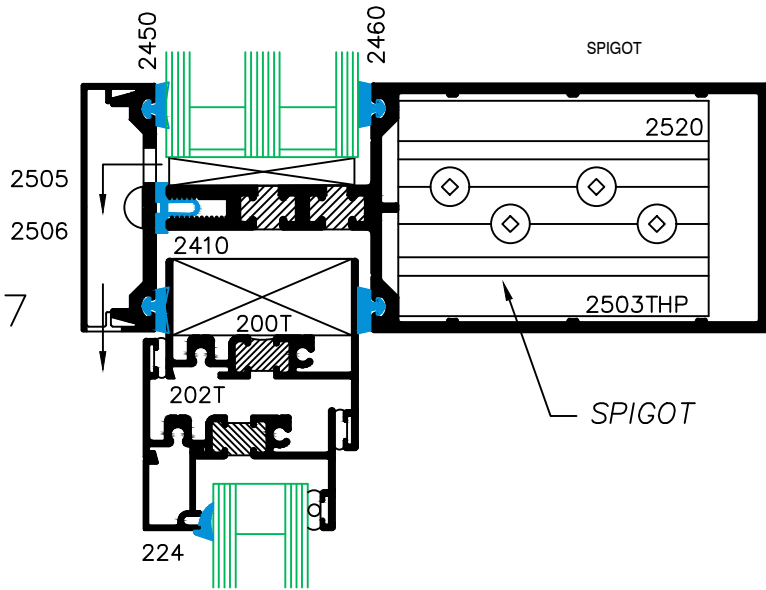

200T SERIES VENT
OPEN-OUT
OUTSIDE GLAZED

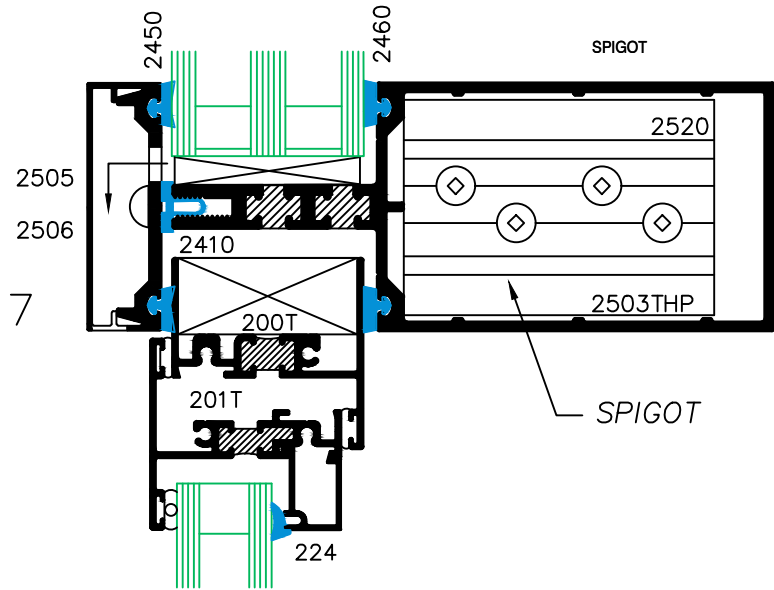

200T SERIES VENT
OPEN-OUT
INSIDE GLAZED

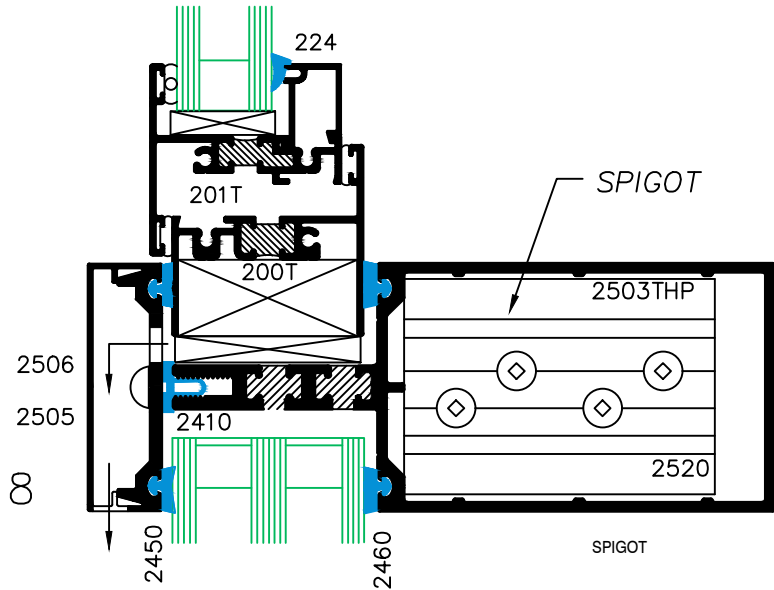
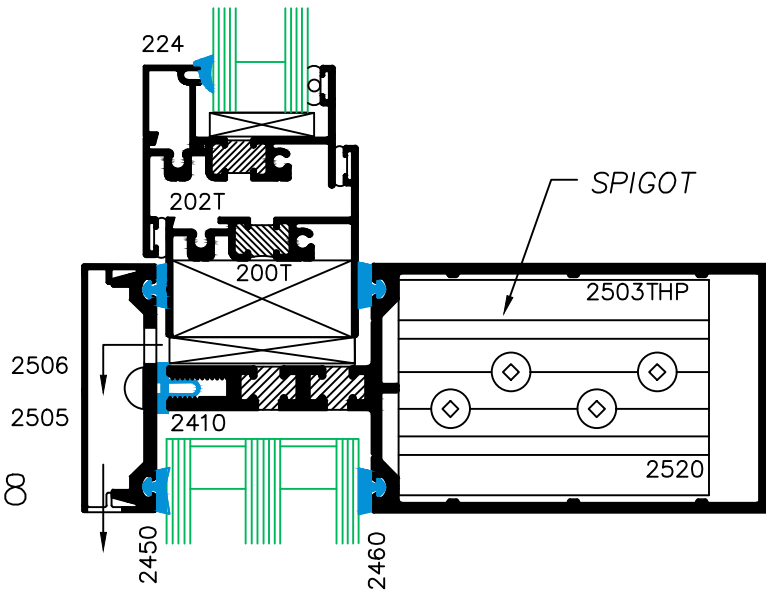

TYPICAL CAPTURED CORNER DETAILS

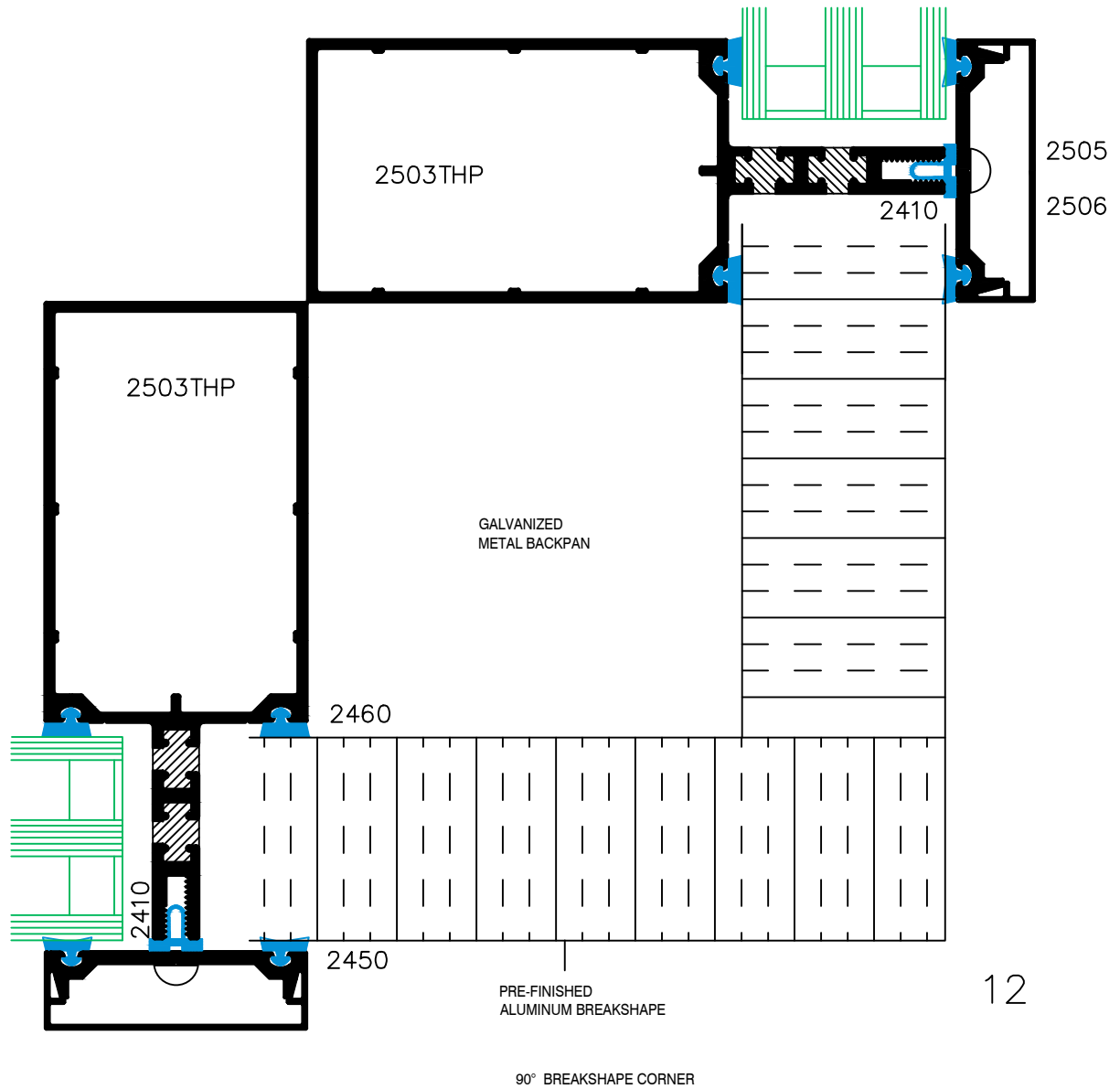



TYPICAL BUTT-JOINT CORNER DETAILS

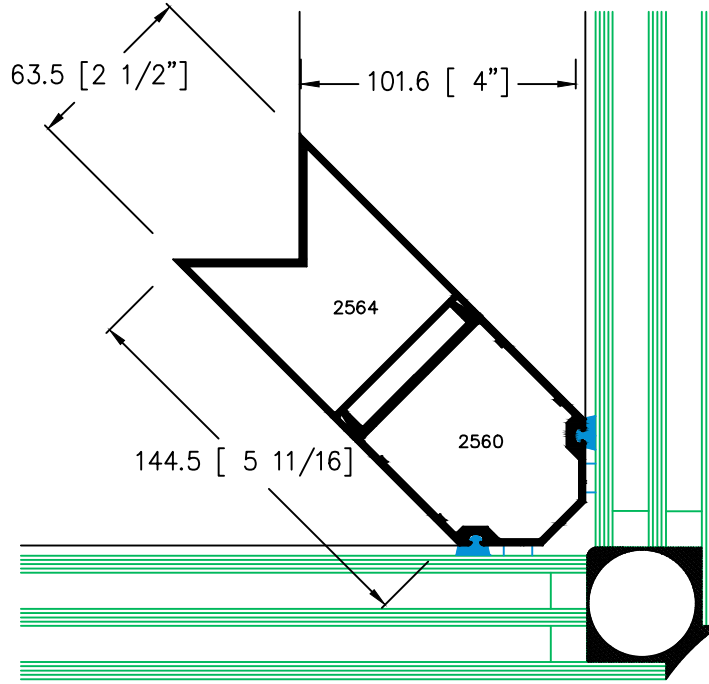

90° BUTT-JOINT CORNER
AT 4" BACK MEMBER

13

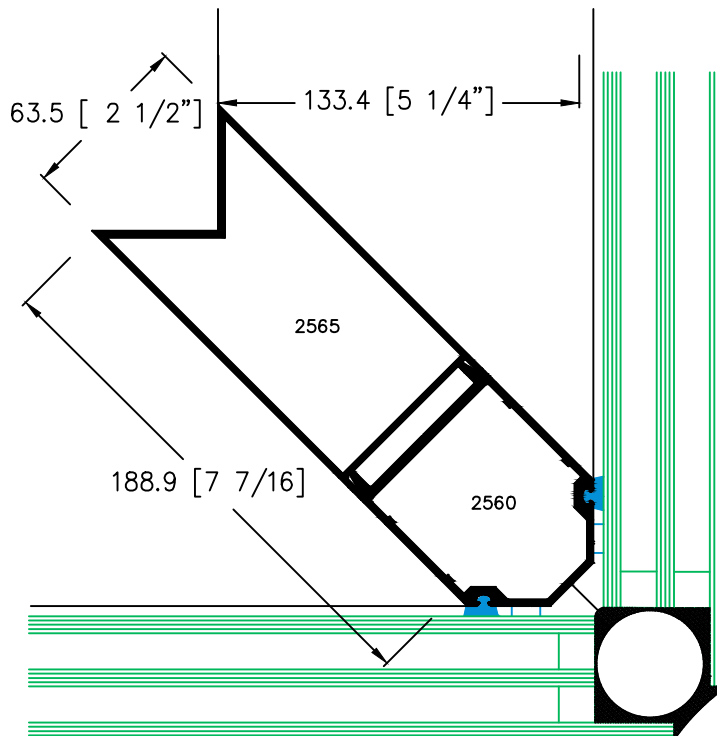

90° BUTT-JOINT CORNER
AT 5 1/4" BACK MEMBER

14

ALTERNATE DOOR DETAILS

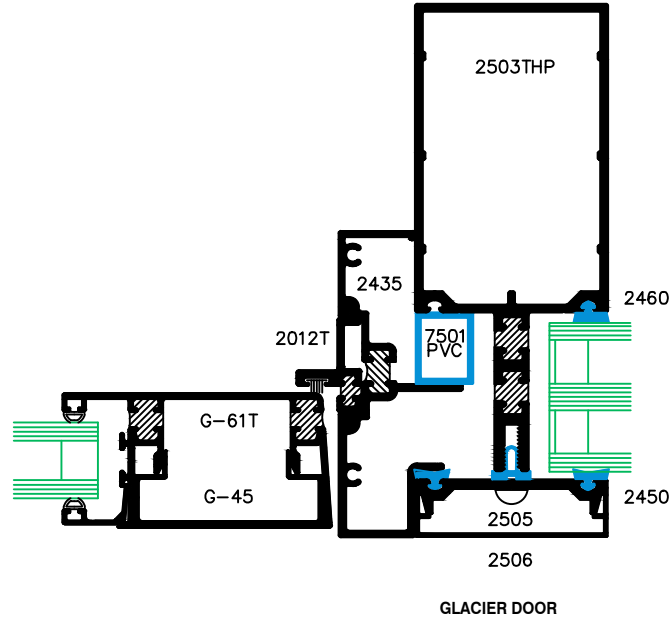

15a

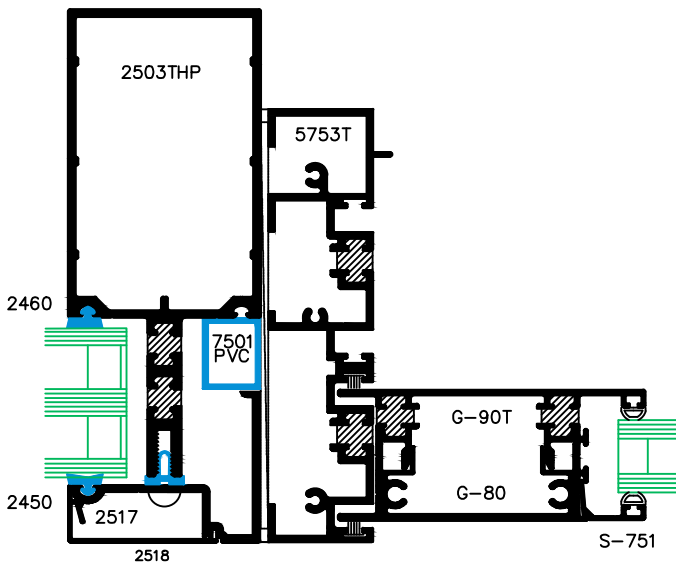

1100T JAMB AT SLIDER

16

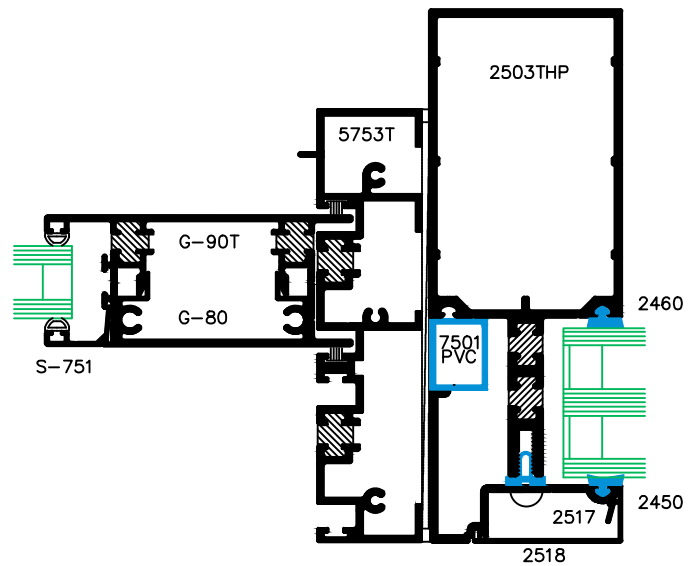

1100T JAMB AT FIXED PANEL

16a

SLIDING DOORS



**METRO
ALUMINUM**
Products Ltd.

2500THP SERIES
TRIPLE GLAZED - THERMALLY BROKEN
CURTAIN WALL & WINDOW SYSTEM
2 1/2" (63.5 mm) - FRAME

**D
58E**

**INTERFACE DETAILS
(SUGGESTED ONLY)**

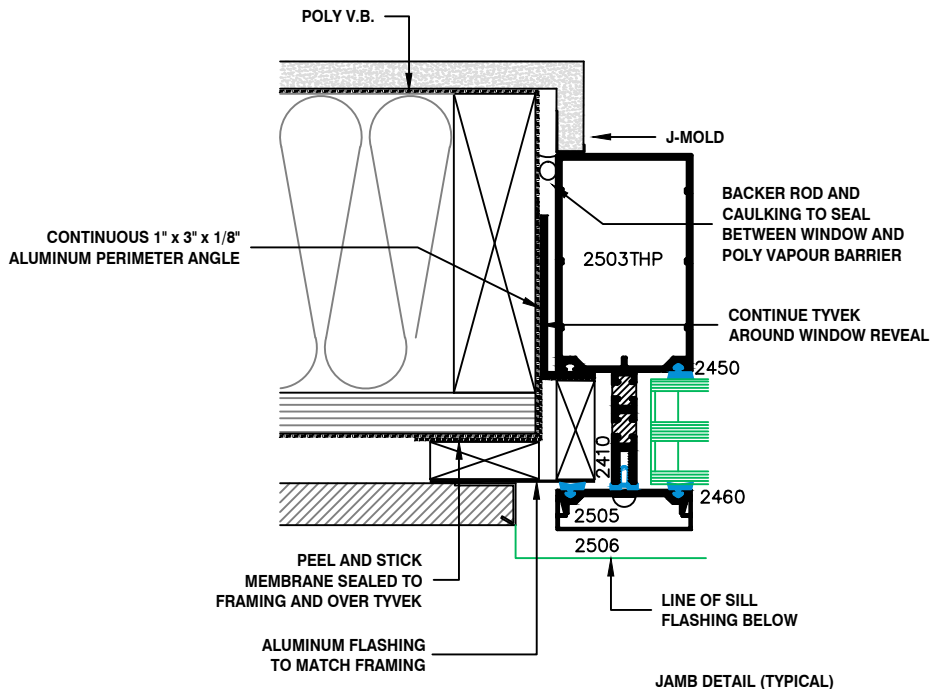
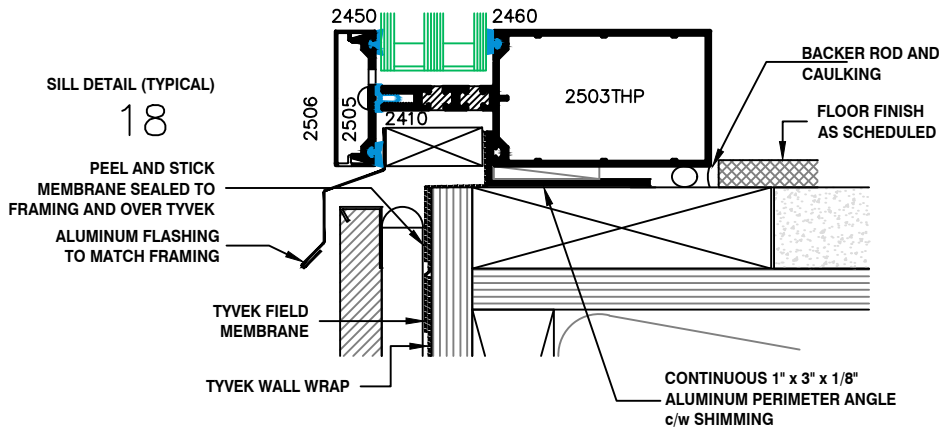
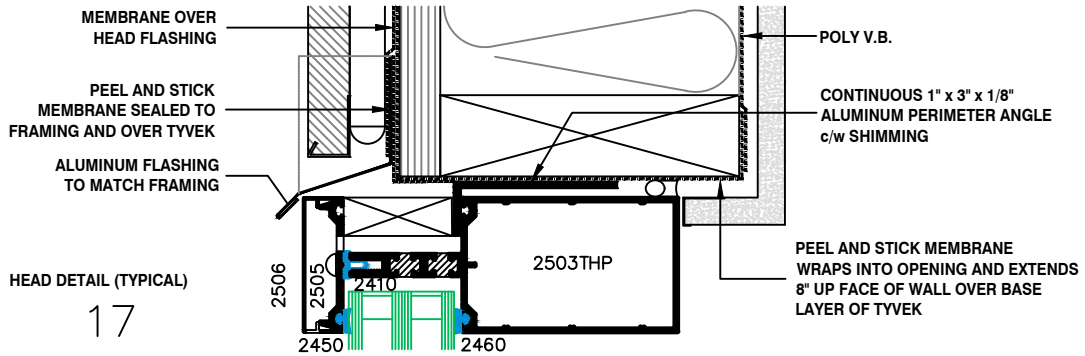

TYPICAL ANCHORING DETAILS

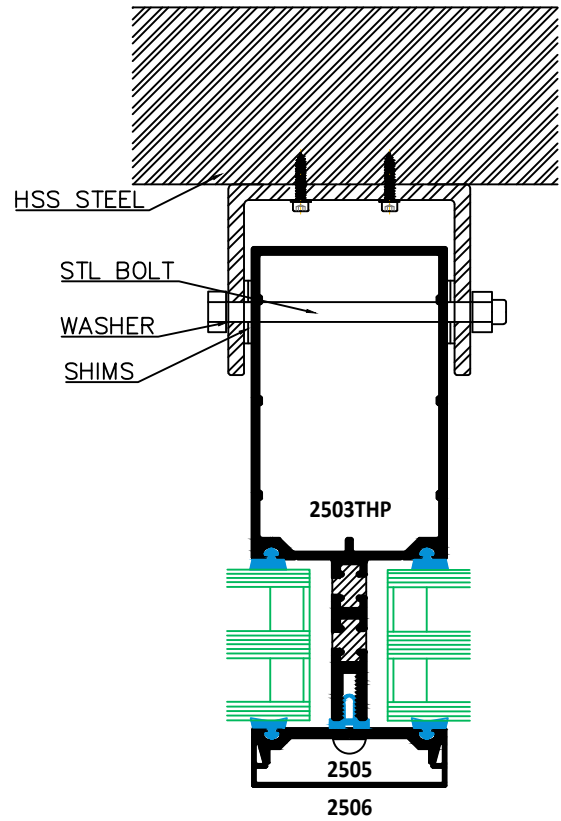
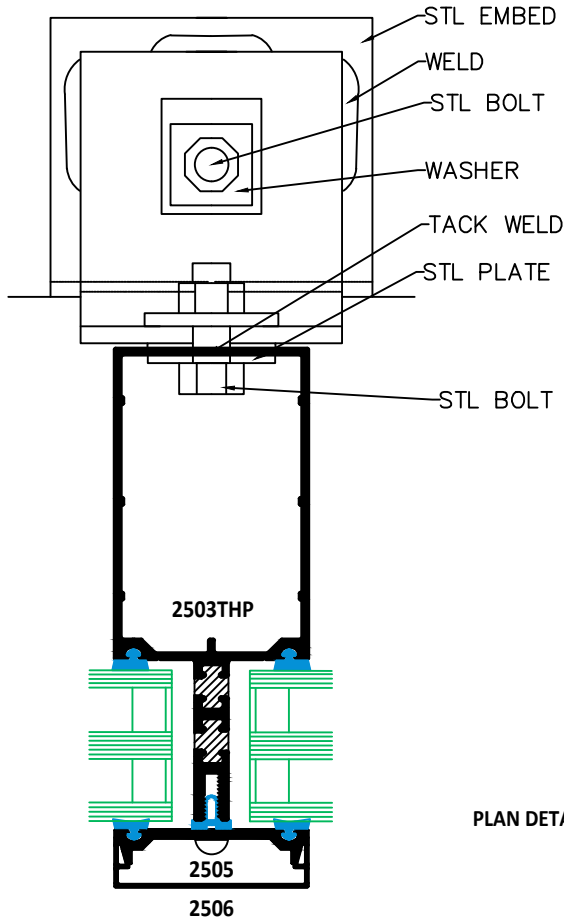

PLAN DETAILS

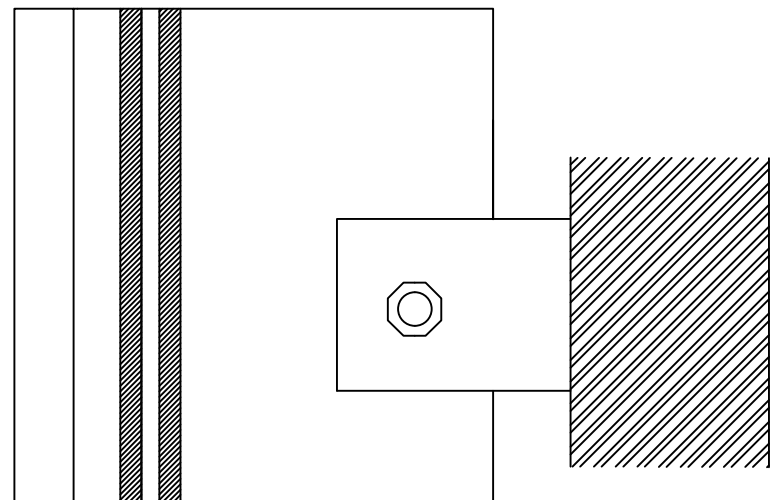
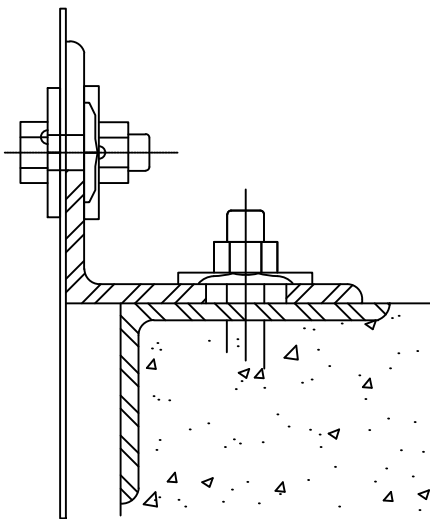

SECTION DETAILS



**METRO
ALUMINUM**
Products Ltd.

2500THP SERIES
TRIPLE GLAZED - THERMALLY BROKEN
CURTAIN WALL & WINDOW SYSTEM
NARROW - 2 1/2" (63.5 mm) - FRAME

**D
58G**

EXPANSION & SPLICE DETAILS

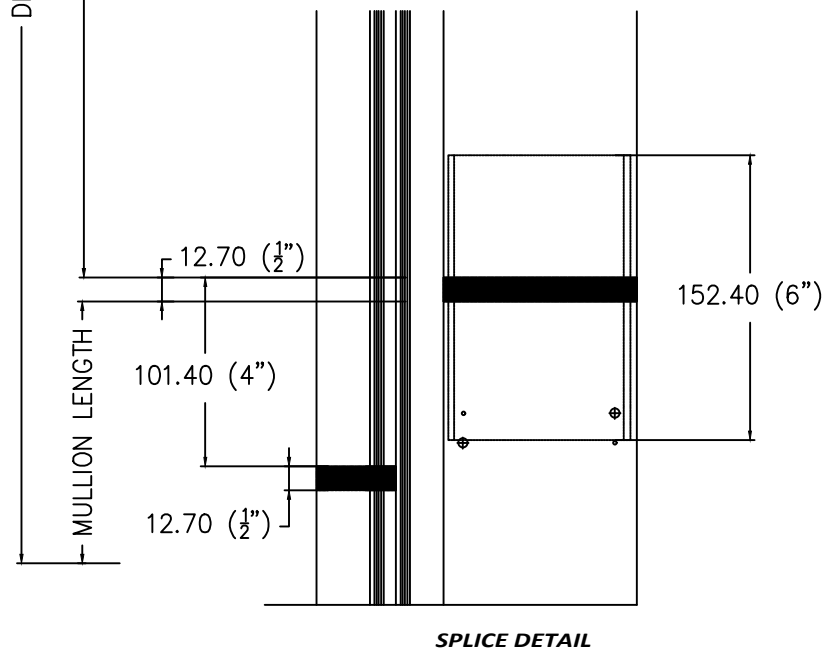
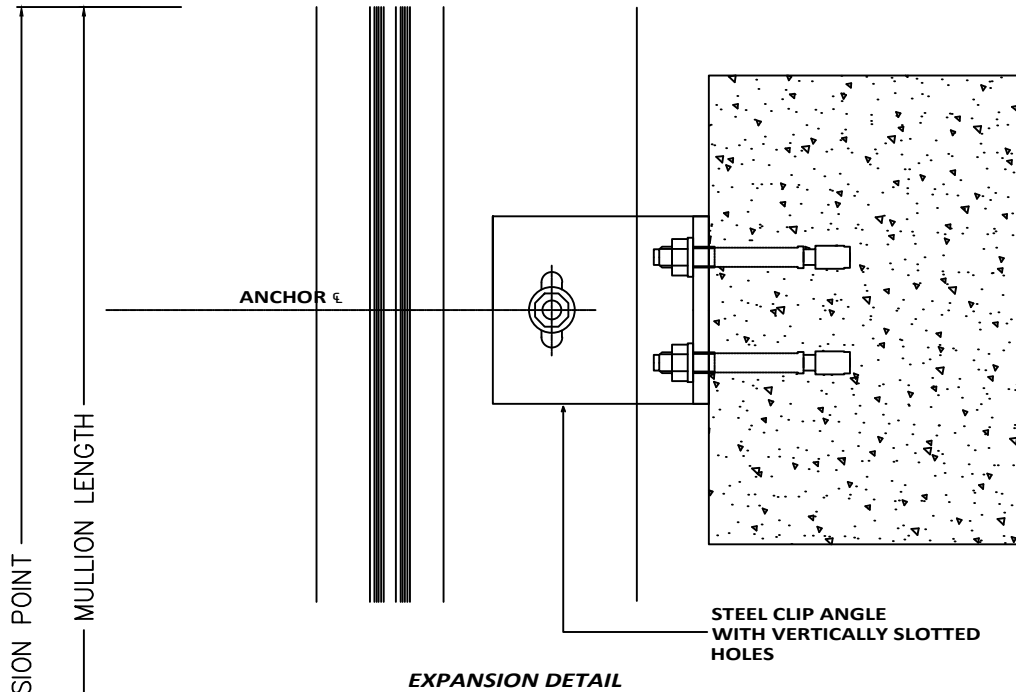

WIND LOAD CHART FOR 2 1/2" x 4" T/G MULLION - PART # 2503THP

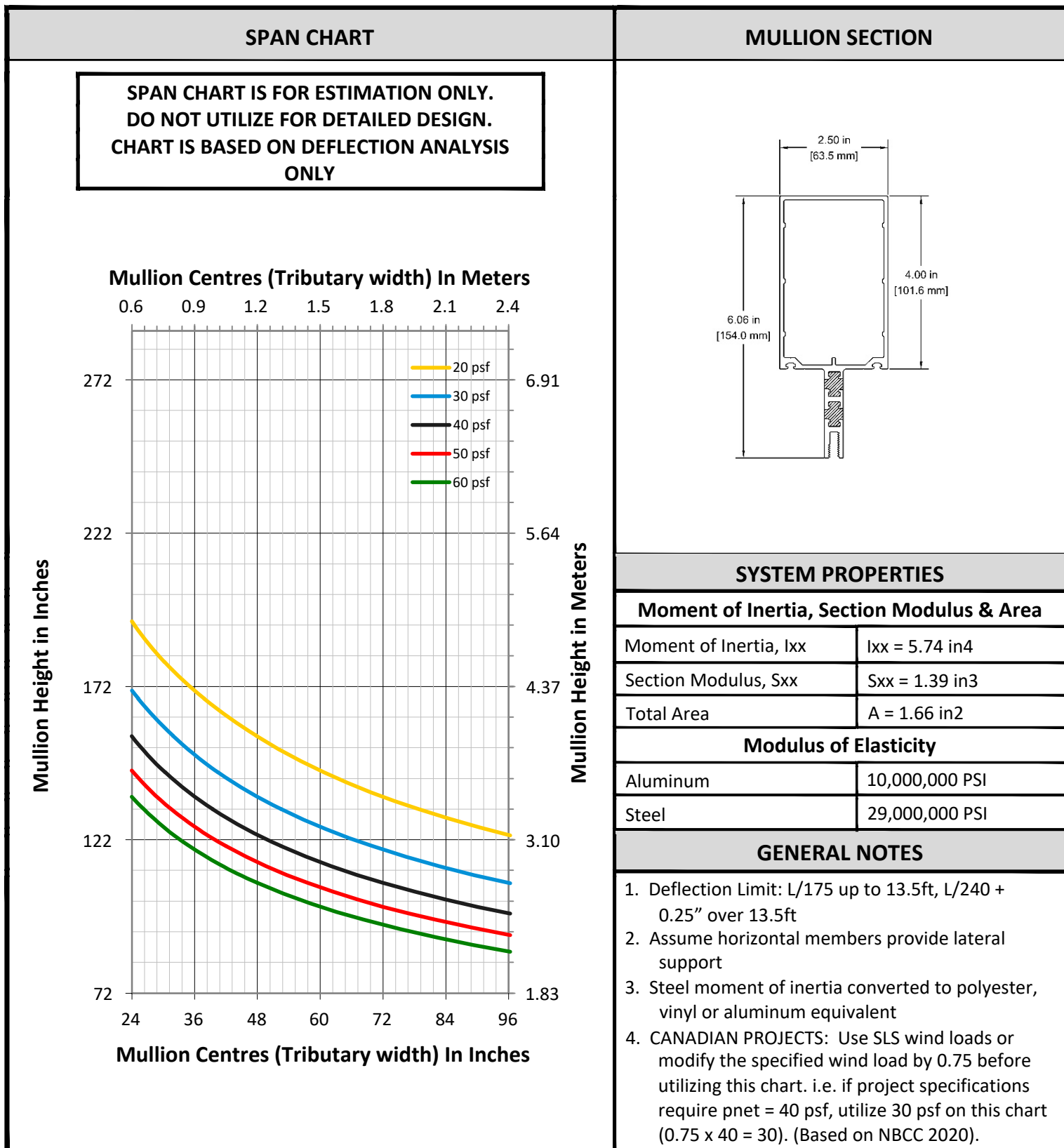

STEEL LOADED WIND LOAD CHART FOR 2 1/2" x 4" T/G MULLION - PART # 2503THP

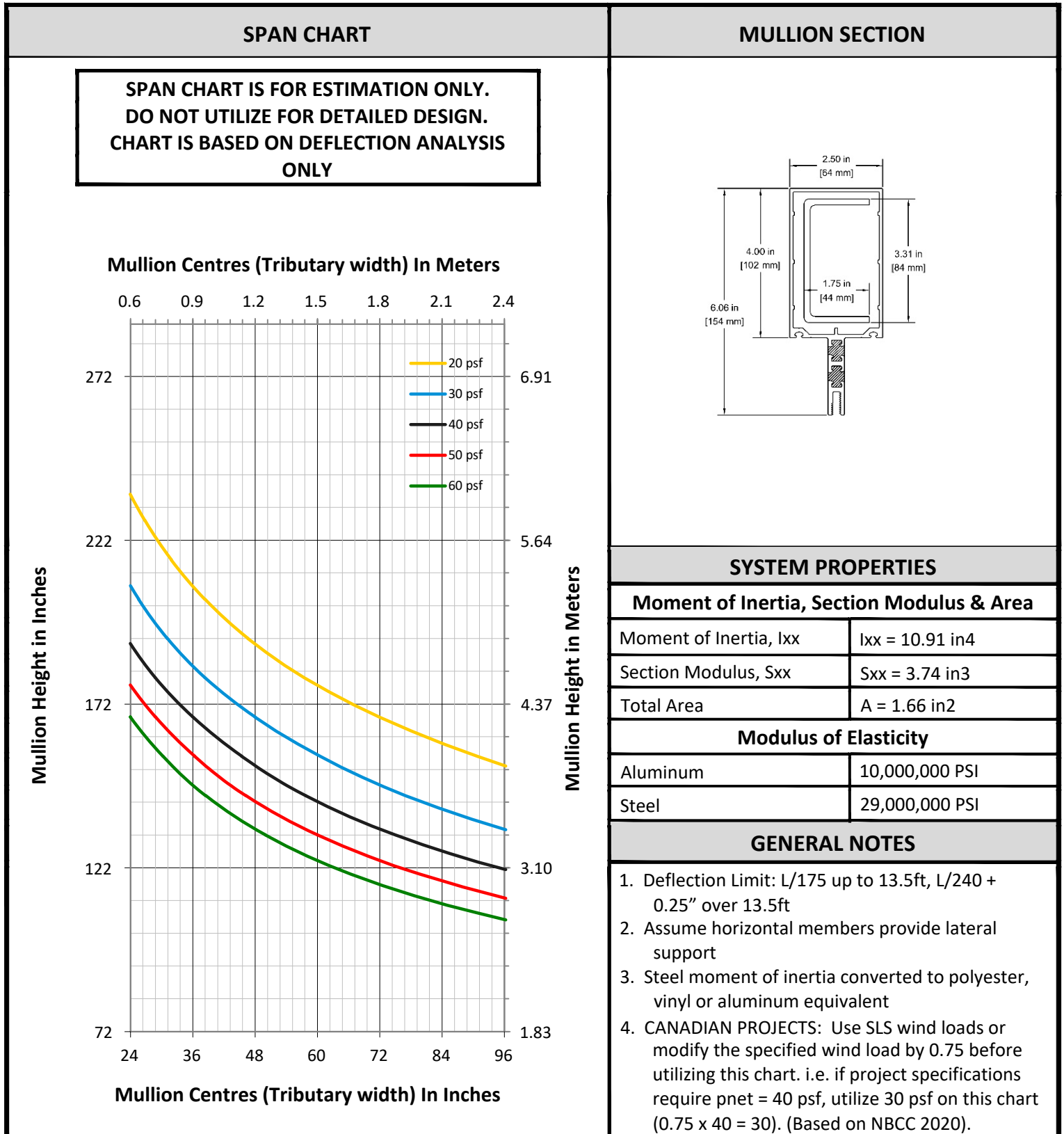

DEAD LOAD CHART FOR 2 1/2" x 4" T/G MULLION - PART # 2503THP

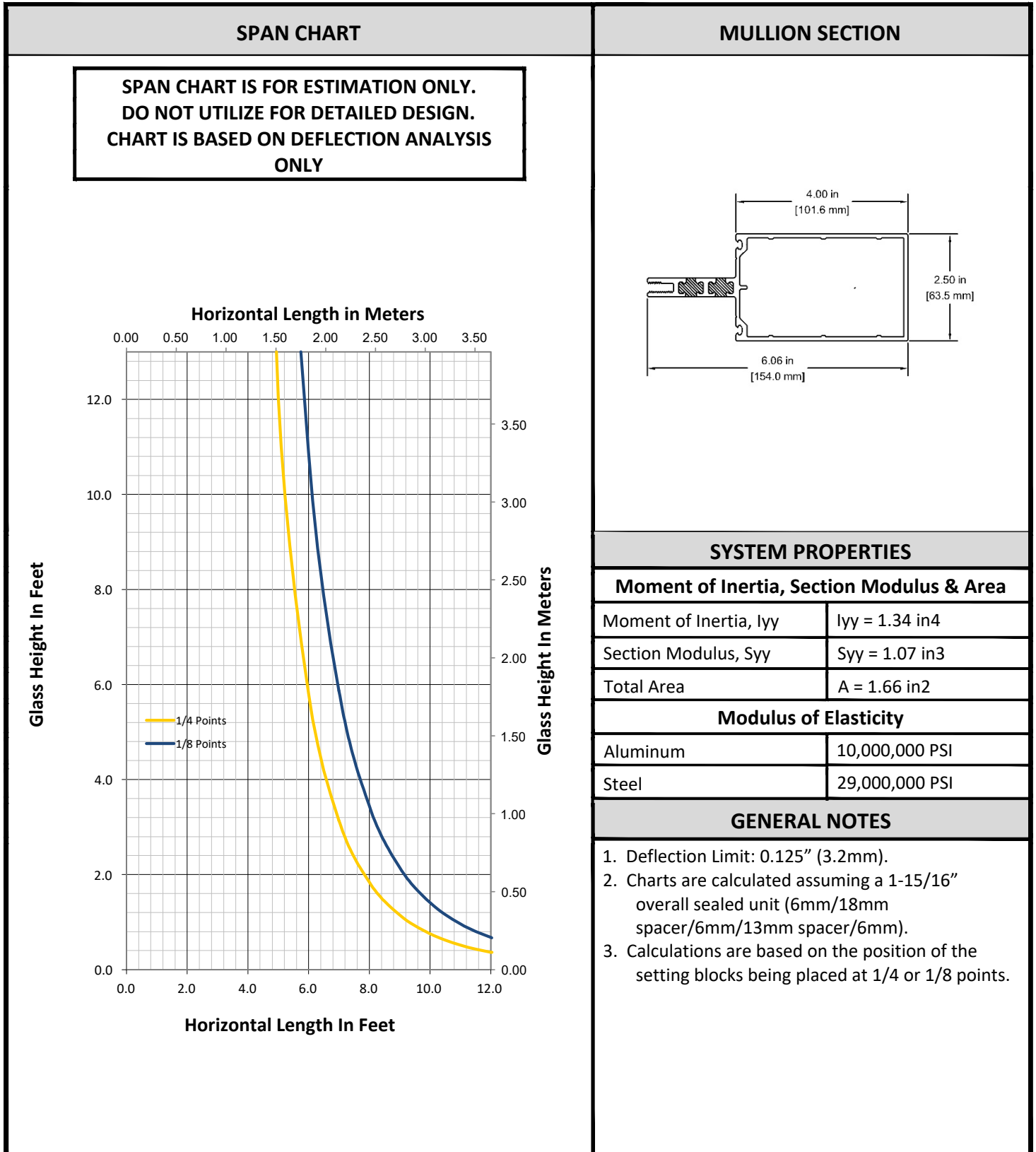

WIND LOAD CHART FOR 2 1/2" x 4" T/G SSG MULLION - PART # 2523

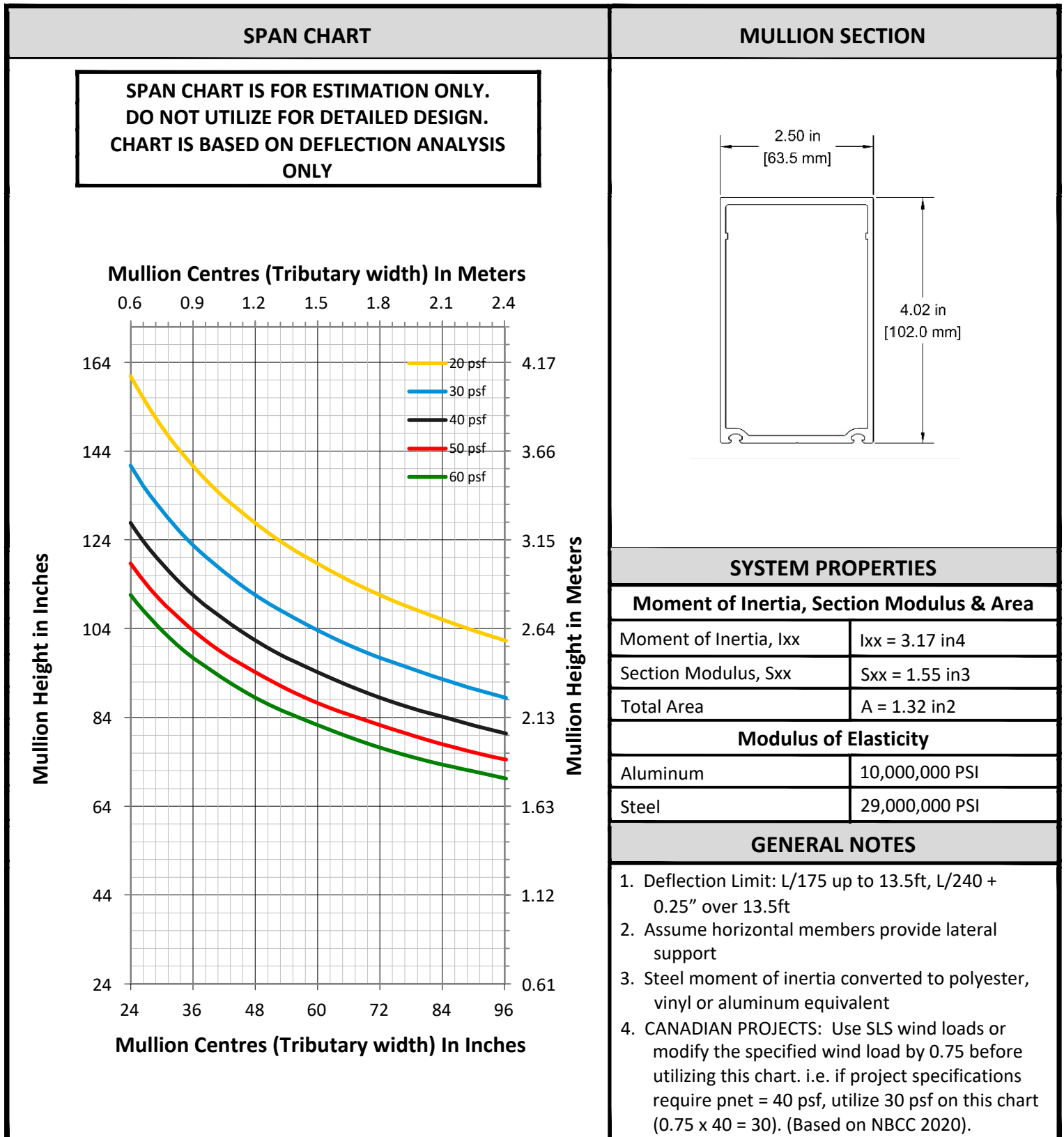

STEEL LOADED WIND LOAD CHART FOR 2 1/2" x 4" T/G SSG MULLION - PART # 2523

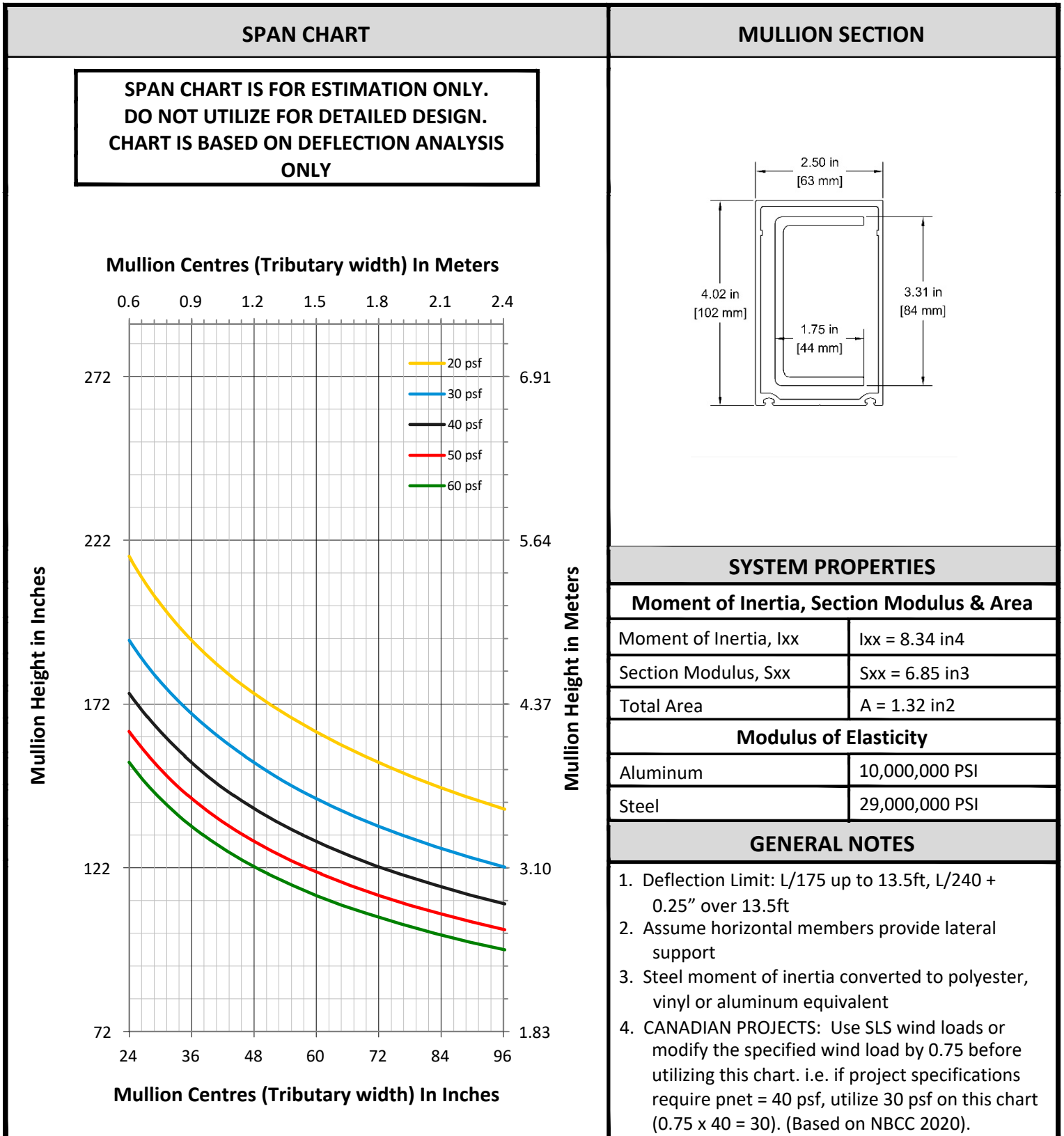

DEAD LOAD CHART FOR 2 1/2" x 4" T/G SSG MULLION - PART #2523

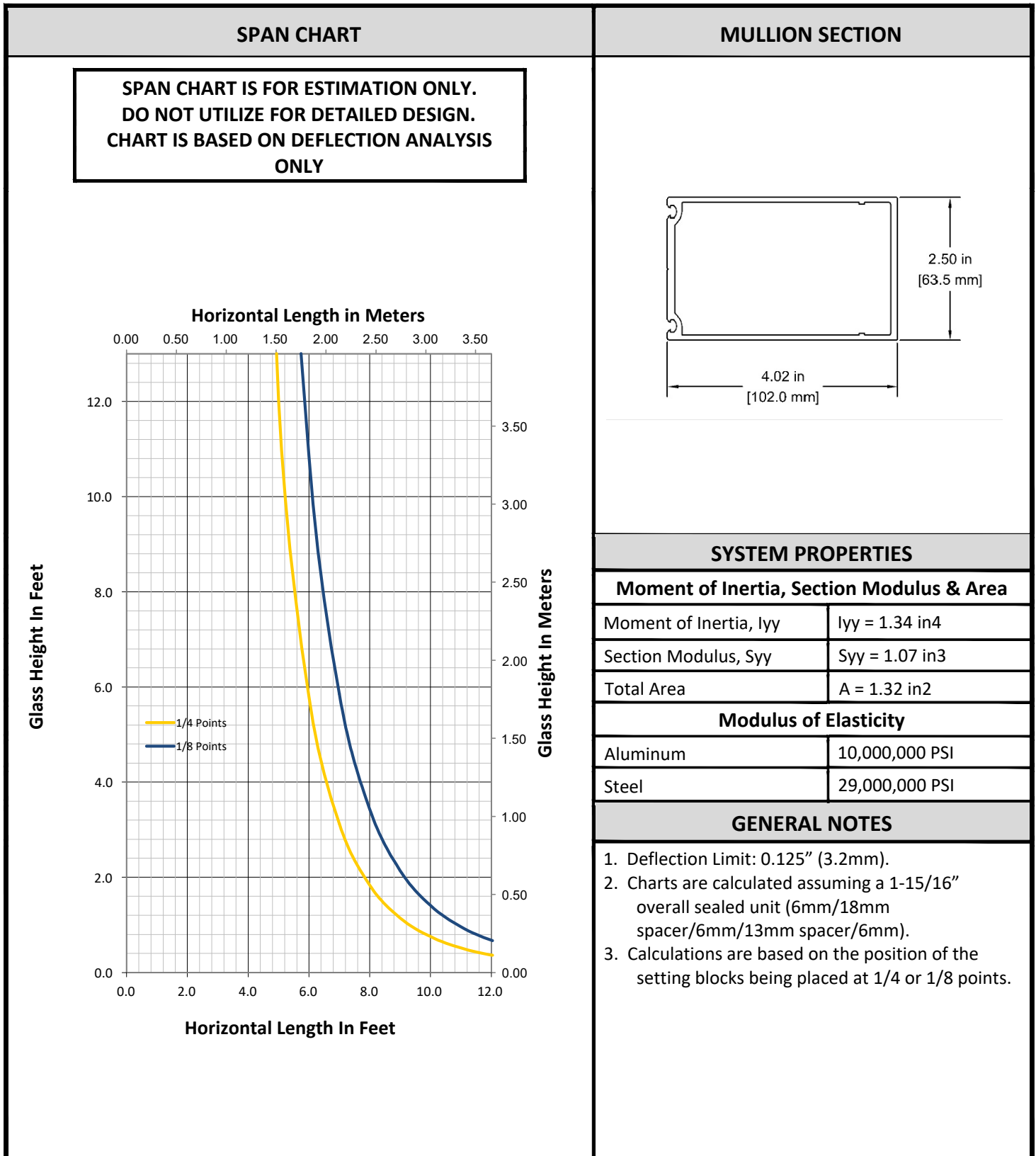

WIND LOAD CHART FOR 2 1/2" x 5 1/4" T/G MULLION - PART # 2504THP

SPAN CHART

SPAN CHART IS FOR ESTIMATION ONLY.
DO NOT UTILIZE FOR DETAILED DESIGN.
CHART IS BASED ON DEFLECTION ANALYSIS
ONLY

Mullion Centres (Tributary width) In Meters

0.6 0.9 1.2 1.5 1.8 2.1 2.4

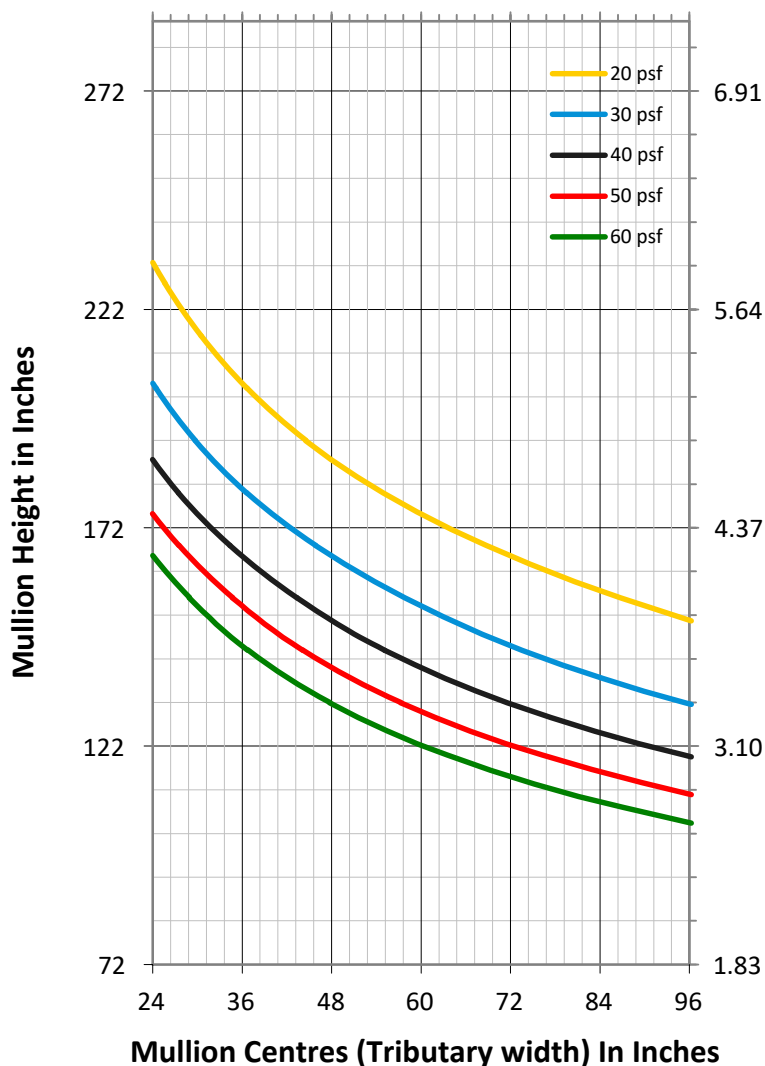

MULLION SECTION

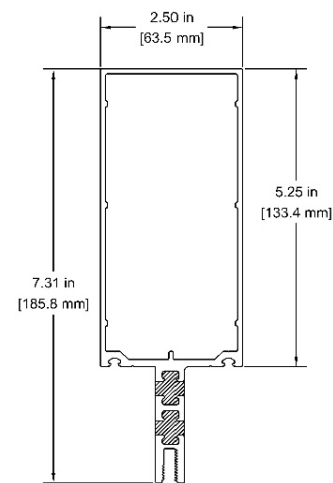

SYSTEM PROPERTIES

Moment of Inertia, Section Modulus & Area

Moment of Inertia, Ixx	Ixx = 10.42 in ⁴
Section Modulus, Sxx	Sxx = 2.11 in ³
Total Area	A = 1.60 in ²

Modulus of Elasticity

Aluminum	10,000,000 PSI
Steel	29,000,000 PSI

GENERAL NOTES

1. Deflection Limit: L/175 up to 13.5ft, L/240 + 0.25" over 13.5ft
2. Assume horizontal members provide lateral support
3. Steel moment of inertia converted to polyester, vinyl or aluminum equivalent
4. CANADIAN PROJECTS: Use SLS wind loads or modify the specified wind load by 0.75 before utilizing this chart. i.e. if project specifications require pnet = 40 psf, utilize 30 psf on this chart (0.75 x 40 = 30). (Based on NBCC 2020).

STEEL LOADED WIND LOAD CHART FOR 2 1/2" x 5 1/4" T/G MULLION - PART # 2504THP

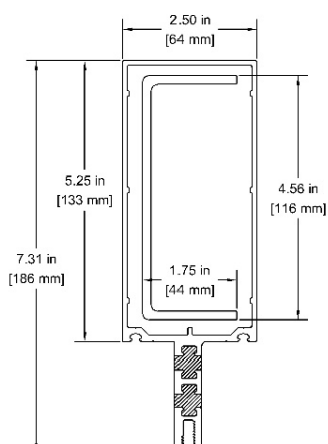
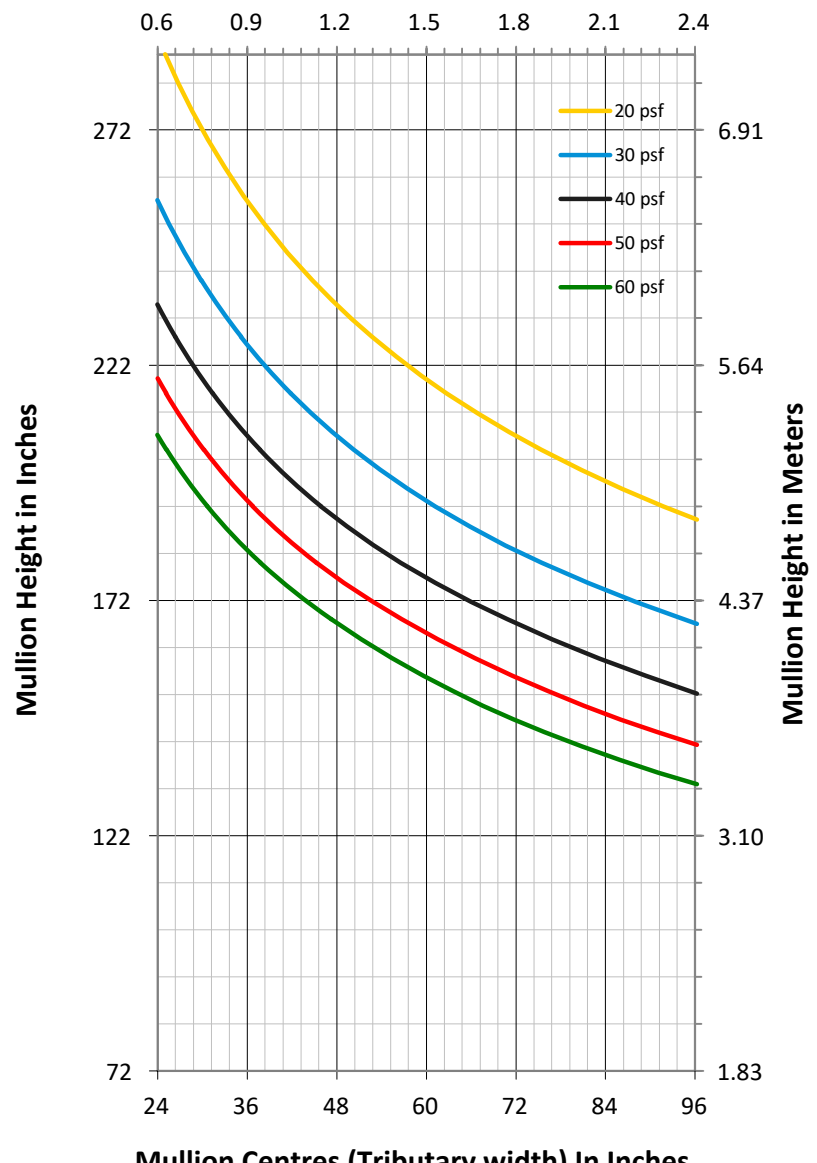
SPAN CHART	MULLION SECTION																				
<p>SPAN CHART IS FOR ESTIMATION ONLY. DO NOT UTILIZE FOR DETAILED DESIGN. CHART IS BASED ON DEFLECTION ANALYSIS ONLY</p>																					
<p style="text-align: center;">Mullion Centres (Tributary width) In Meters</p> <p style="text-align: center;">0.6 0.9 1.2 1.5 1.8 2.1 2.4</p>  <p style="text-align: center;">Mullion Centres (Tributary width) In Inches</p> <p style="text-align: center;">24 36 48 60 72 84 96</p>	<table border="1" style="width: 100%; border-collapse: collapse;"> <thead> <tr> <th colspan="2" style="text-align: center;">SYSTEM PROPERTIES</th> </tr> <tr> <th colspan="2" style="text-align: center;">Moment of Inertia, Section Modulus & Area</th> </tr> </thead> <tbody> <tr> <td>Moment of Inertia, Ixx</td> <td>Ixx = 21.48 in⁴</td> </tr> <tr> <td>Section Modulus, Sxx</td> <td>Sxx = 11.45 in³</td> </tr> <tr> <td>Total Area</td> <td>A = 1.99 in²</td> </tr> <tr> <th colspan="2" style="text-align: center;">Modulus of Elasticity</th> </tr> <tr> <td>Aluminum</td> <td>10,000,000 PSI</td> </tr> <tr> <td>Steel</td> <td>29,000,000 PSI</td> </tr> <tr> <th colspan="2" style="text-align: center;">GENERAL NOTES</th> </tr> <tr> <td colspan="2"> <ol style="list-style-type: none"> 1. Deflection Limit: L/175 up to 13.5ft, L/240 + 0.25" over 13.5ft 2. Assume horizontal members provide lateral support 3. Steel moment of inertia converted to polyester, vinyl or aluminum equivalent 4. CANADIAN PROJECTS: Use SLS wind loads or modify the specified wind load by 0.75 before utilizing this chart. i.e. if project specifications require pnet = 40 psf, utilize 30 psf on this chart (0.75 x 40 = 30). (Based on NBCC 2020). </td> </tr> </tbody> </table>	SYSTEM PROPERTIES		Moment of Inertia, Section Modulus & Area		Moment of Inertia, Ixx	Ixx = 21.48 in ⁴	Section Modulus, Sxx	Sxx = 11.45 in ³	Total Area	A = 1.99 in ²	Modulus of Elasticity		Aluminum	10,000,000 PSI	Steel	29,000,000 PSI	GENERAL NOTES		<ol style="list-style-type: none"> 1. Deflection Limit: L/175 up to 13.5ft, L/240 + 0.25" over 13.5ft 2. Assume horizontal members provide lateral support 3. Steel moment of inertia converted to polyester, vinyl or aluminum equivalent 4. CANADIAN PROJECTS: Use SLS wind loads or modify the specified wind load by 0.75 before utilizing this chart. i.e. if project specifications require pnet = 40 psf, utilize 30 psf on this chart (0.75 x 40 = 30). (Based on NBCC 2020). 	
SYSTEM PROPERTIES																					
Moment of Inertia, Section Modulus & Area																					
Moment of Inertia, Ixx	Ixx = 21.48 in ⁴																				
Section Modulus, Sxx	Sxx = 11.45 in ³																				
Total Area	A = 1.99 in ²																				
Modulus of Elasticity																					
Aluminum	10,000,000 PSI																				
Steel	29,000,000 PSI																				
GENERAL NOTES																					
<ol style="list-style-type: none"> 1. Deflection Limit: L/175 up to 13.5ft, L/240 + 0.25" over 13.5ft 2. Assume horizontal members provide lateral support 3. Steel moment of inertia converted to polyester, vinyl or aluminum equivalent 4. CANADIAN PROJECTS: Use SLS wind loads or modify the specified wind load by 0.75 before utilizing this chart. i.e. if project specifications require pnet = 40 psf, utilize 30 psf on this chart (0.75 x 40 = 30). (Based on NBCC 2020). 																					

DEAD LOAD CHART FOR 2 1/2" x 5 1/4" T/G MULLION - PART # 2504THP

SPAN CHART

**SPAN CHART IS FOR ESTIMATION ONLY.
DO NOT UTILIZE FOR DETAILED DESIGN.
CHART IS BASED ON DEFLECTION ANALYSIS
ONLY**

MULLION SECTION

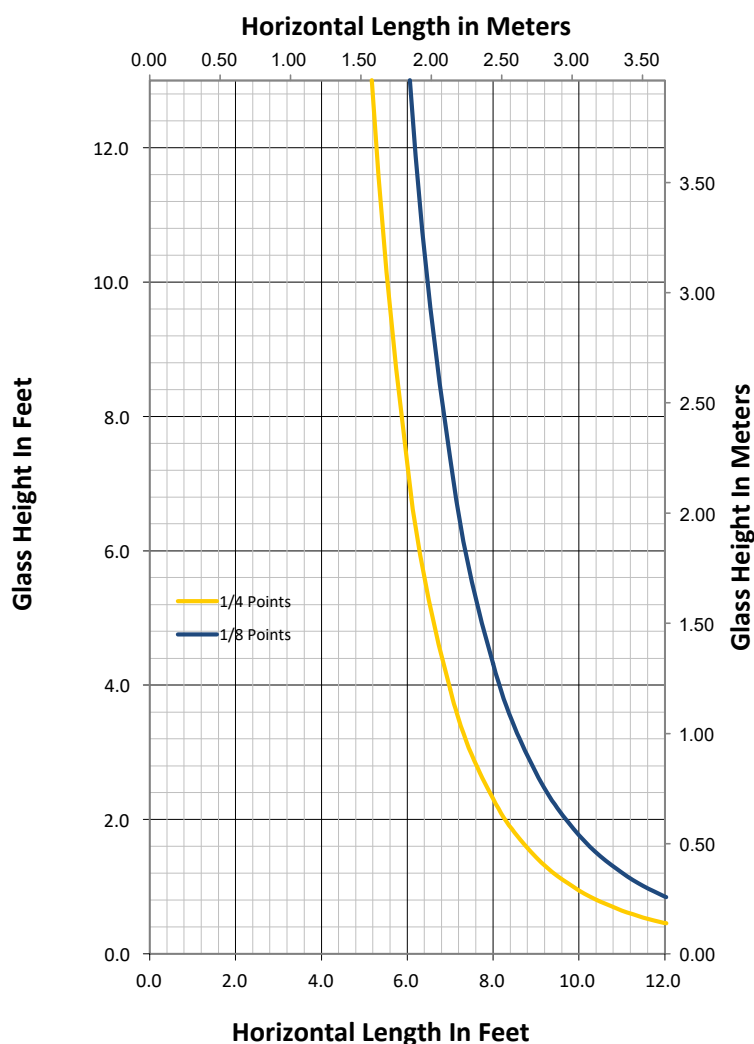
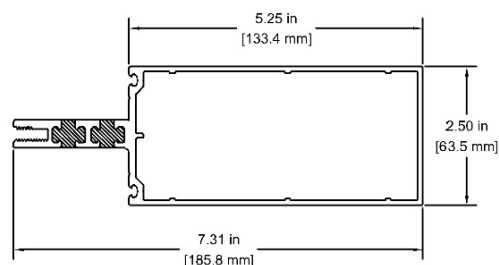

SYSTEM PROPERTIES

Moment of Inertia, Section Modulus & Area

Moment of Inertia, I _{yy}	I _{yy} = 1.69 in ⁴
Section Modulus, S _{yy}	S _{yy} = 1.34 in ³
Total Area	A = 1.99 in ²

Modulus of Elasticity

Aluminum	10,000,000 PSI
Steel	29,000,000 PSI

GENERAL NOTES

1. Deflection Limit: 0.125" (3.2mm).
2. Charts are calculated assuming a 1-15/16" overall sealed unit (6mm/18mm spacer/6mm/13mm spacer/6mm).
3. Calculations are based on the position of the setting blocks being placed at 1/4 or 1/8 points.

WIND LOAD CHART FOR 2 1/2" x 5 1/4" T/G SSG MULLION - PART # 2555

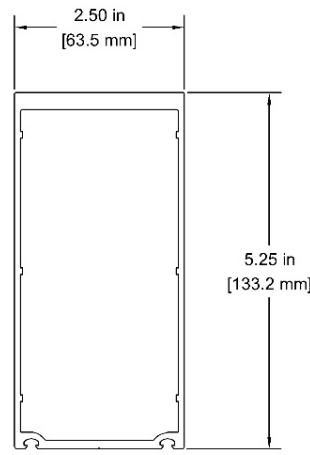
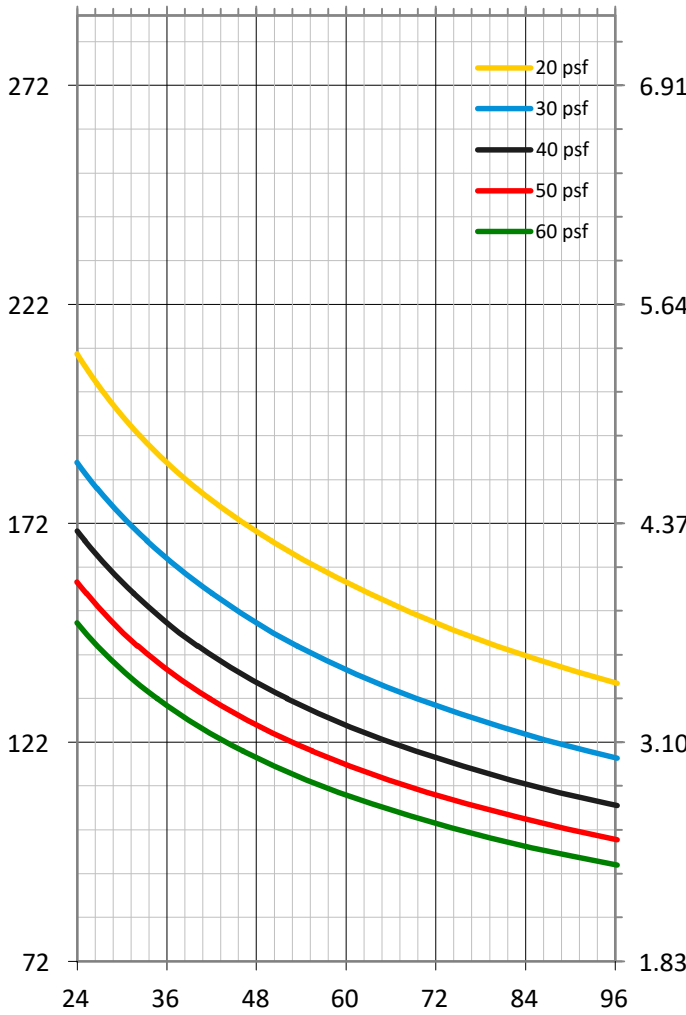
SPAN CHART	MULLION SECTION										
<p>SPAN CHART IS FOR ESTIMATION ONLY. DO NOT UTILIZE FOR DETAILED DESIGN. CHART IS BASED ON DEFLECTION ANALYSIS ONLY</p>											
<p style="text-align: center;">Mullion Centres (Tributary width) In Meters</p> <p style="text-align: center;">0.6 0.9 1.2 1.5 1.8 2.1 2.4</p> <div style="display: flex; justify-content: space-between;"> <div style="width: 45%;"> <p style="transform: rotate(-90deg); transform-origin: left top;">Mullion Height in Inches</p> <p style="text-align: right;">272 222 172 122 72</p> </div> <div style="width: 50%; text-align: right;"> <p>6.91 5.64 4.37 3.10 1.83</p> </div> </div>  <p style="text-align: center;">Mullion Centres (Tributary width) In Inches</p> <p style="text-align: center;">24 36 48 60 72 84 96</p>	<p style="text-align: center; background-color: #cccccc;">SYSTEM PROPERTIES</p> <p style="text-align: center;">Moment of Inertia, Section Modulus & Area</p> <table border="1" style="width: 100%; border-collapse: collapse;"> <tr> <td style="width: 60%;">Moment of Inertia, I_{xx}</td> <td>I_{xx} = 7.58 in⁴</td> </tr> <tr> <td>Section Modulus, S_{xx}</td> <td>S_{xx} = 2.55 in³</td> </tr> <tr> <td>Total Area</td> <td>A = 1.85 in²</td> </tr> </table> <p style="text-align: center;">Modulus of Elasticity</p> <table border="1" style="width: 100%; border-collapse: collapse;"> <tr> <td style="width: 60%;">Aluminum</td> <td>10,000,000 PSI</td> </tr> <tr> <td>Steel</td> <td>29,000,000 PSI</td> </tr> </table> <p style="text-align: center; background-color: #cccccc;">GENERAL NOTES</p> <ol style="list-style-type: none"> 1. Deflection Limit: L/175 up to 13.5ft, L/240 + 0.25" over 13.5ft 2. Assume horizontal members provide lateral support 3. Steel moment of inertia converted to polyester, vinyl or aluminum equivalent 4. CANADIAN PROJECTS: Use SLS wind loads or modify the specified wind load by 0.75 before utilizing this chart. i.e. if project specifications require pnet = 40 psf, utilize 30 psf on this chart (0.75 x 40 = 30). (Based on NBCC 2020). 	Moment of Inertia, I _{xx}	I _{xx} = 7.58 in ⁴	Section Modulus, S _{xx}	S _{xx} = 2.55 in ³	Total Area	A = 1.85 in ²	Aluminum	10,000,000 PSI	Steel	29,000,000 PSI
Moment of Inertia, I _{xx}	I _{xx} = 7.58 in ⁴										
Section Modulus, S _{xx}	S _{xx} = 2.55 in ³										
Total Area	A = 1.85 in ²										
Aluminum	10,000,000 PSI										
Steel	29,000,000 PSI										

STEEL LOADED WIND LOAD CHART FOR 2 1/2" x 5 1/4" T/G SSG MULLION - PART # 2555

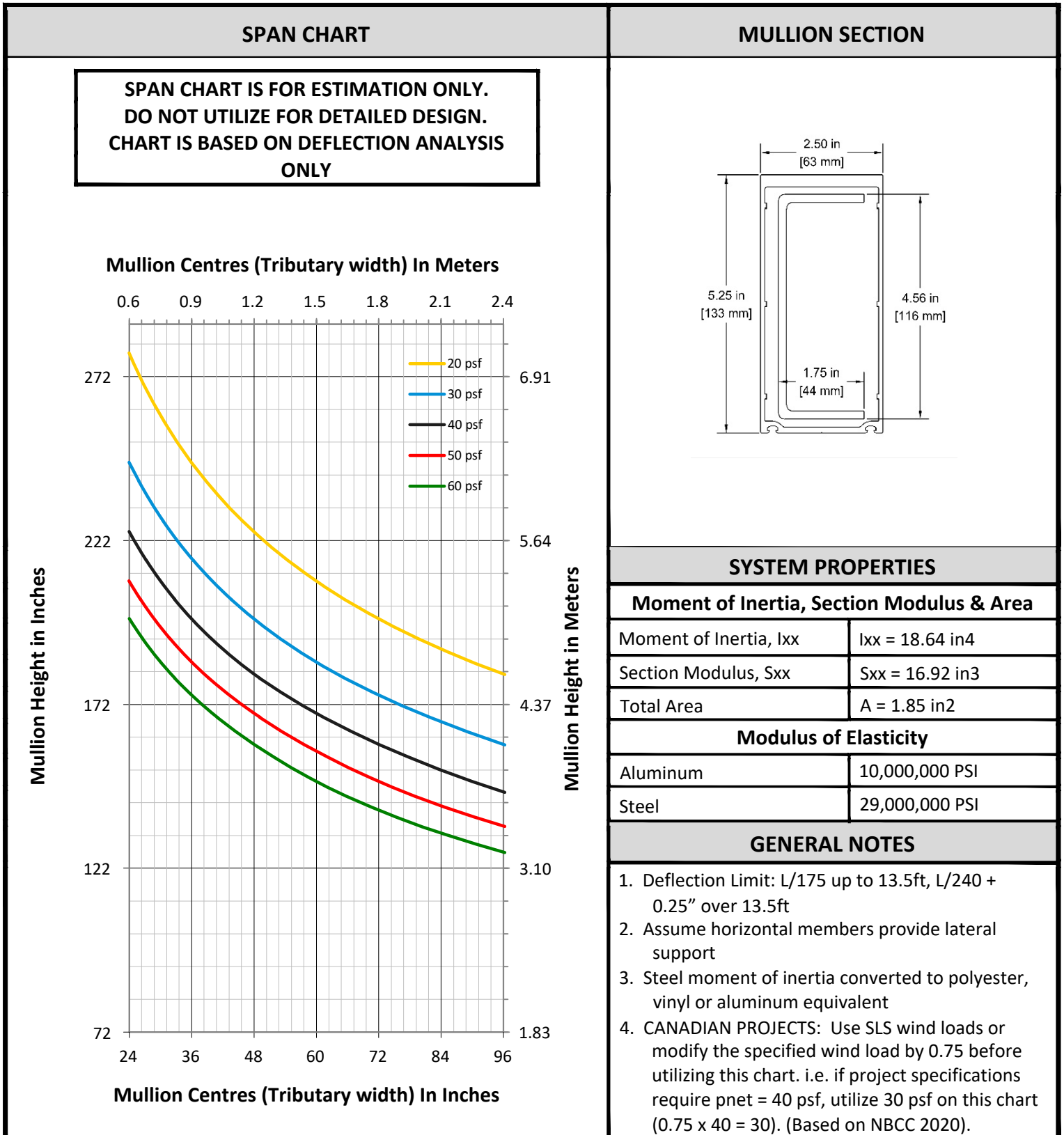

DEAD LOAD CHART FOR 2 1/2" x 5 1/4" T/G SSG MULLION - PART # 2555

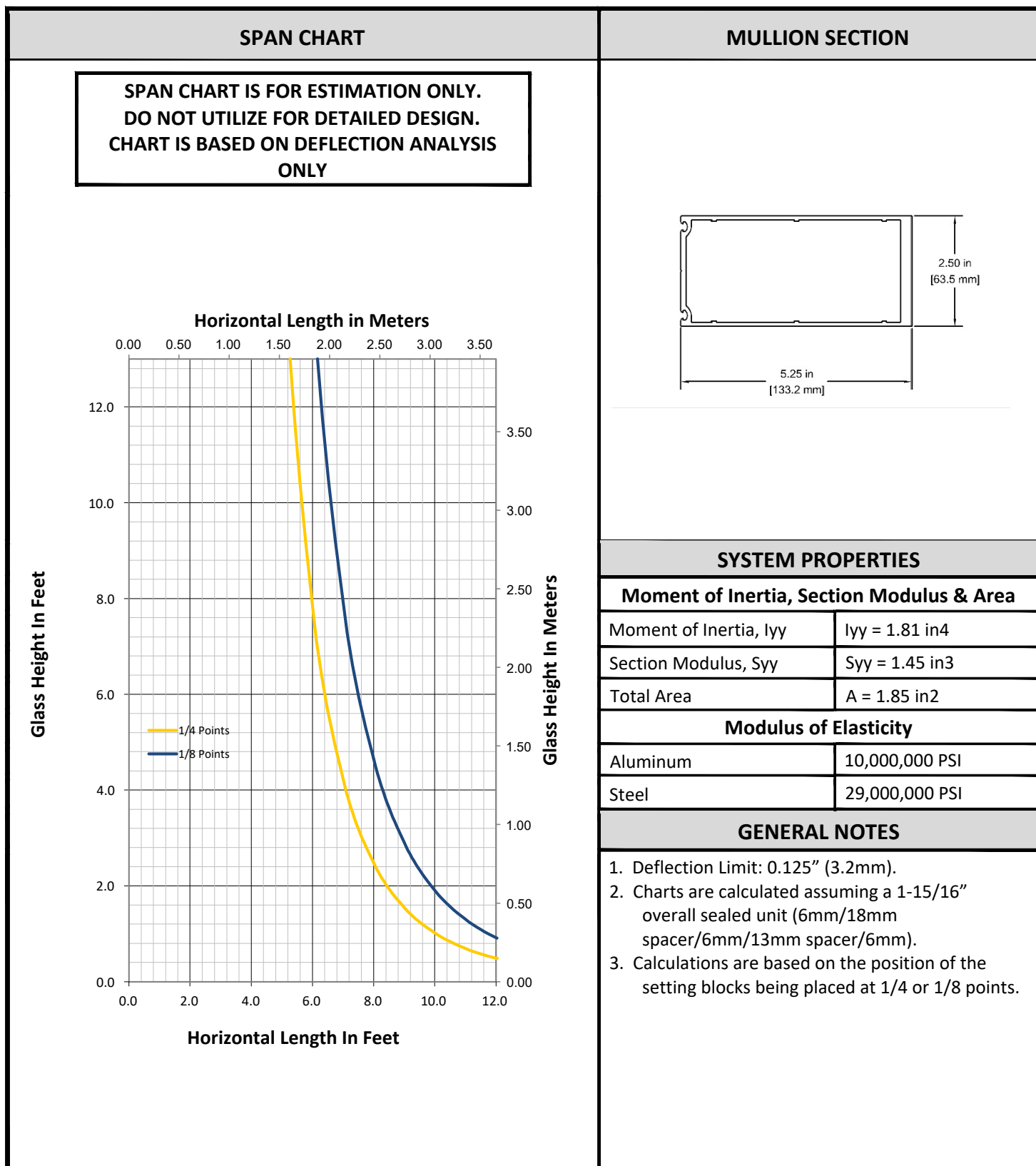

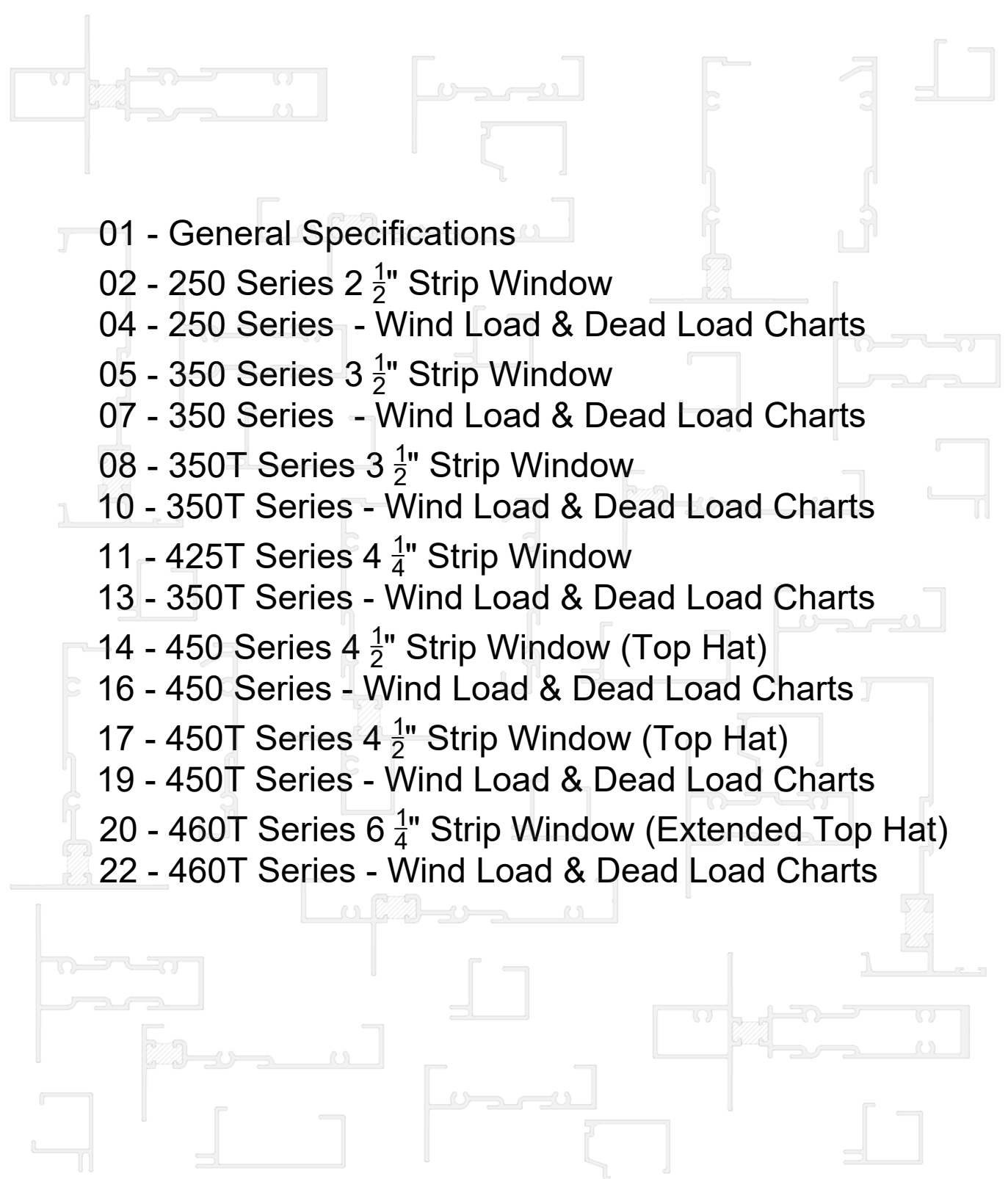
- 
- 01 - General Specifications
 - 02 - 250 Series 2 $\frac{1}{2}$ " Strip Window
 - 04 - 250 Series - Wind Load & Dead Load Charts
 - 05 - 350 Series 3 $\frac{1}{2}$ " Strip Window
 - 07 - 350 Series - Wind Load & Dead Load Charts
 - 08 - 350T Series 3 $\frac{1}{2}$ " Strip Window
 - 10 - 350T Series - Wind Load & Dead Load Charts
 - 11 - 425T Series 4 $\frac{1}{4}$ " Strip Window
 - 13 - 350T Series - Wind Load & Dead Load Charts
 - 14 - 450 Series 4 $\frac{1}{2}$ " Strip Window (Top Hat)
 - 16 - 450 Series - Wind Load & Dead Load Charts
 - 17 - 450T Series 4 $\frac{1}{2}$ " Strip Window (Top Hat)
 - 19 - 450T Series - Wind Load & Dead Load Charts
 - 20 - 460T Series 6 $\frac{1}{4}$ " Strip Window (Extended Top Hat)
 - 22 - 460T Series - Wind Load & Dead Load Charts



Part 1 - GENERAL

Scope - The fixed window framing system shall be _____ Series as manufactured by METRO ALUMINUM Products Ltd. Supply and install aluminum framing, as described on the architectural drawings and as specified herein.

Work Not Included - See: Specifier's lists of excluded items; Items furnished but not installed and/or Items installed but not furnished.

Related Work Specified Elsewhere - See: Specifier's lists and related Sections.

Design & Performance Requirements - Framing shall fully comply with applicable standard specifications as typically referenced to the following performance requirements criteria: Air Tightness, Water Tightness, Wind (and other applicable) Load Resistance, Temperature Index and Energy Performance – an others as described in CAN/CSA-A440-M90 - Windows - (Specifier's selection)

Submittals - Shop Drawings & Samples - Submit all documentation and samples for review by Consultant at one time, prior to fabrication of curtain wall products.

Quality Assurance - Provide all necessary information to show that all involved products meet or exceed the requirements of these specifications.

Delivery, Storage and Handling - Deliver, store, handle, protect and schedule materials and products so as to avoid any damage. Follow recommendations of AAMA CW-10 "Care and Handling of Architectural Aluminum from Shop to Site" and others as applicable.

Part 2 - PRODUCTS

Materials - All materials to meet the applicable minimum design and specifications requirements. Any defects impairing strength, durability or appearance are not acceptable. Extruded aluminum shall be AA 6063 T6 alloy and temper - $F_y = 110 \text{ MPa}$ (16 KSI) minimum. Sufficient strength and size assembly and anchoring shall be made of corrosion-resistant and compatible material such as cadmium or zinc plated carbon steel or stainless steel. Separate incompatible materials and prevent galvanic action (electrolytic corrosion). Structurally adequate anchoring metal brackets shall be anticorrosive painted. Conventional wet-dry, inside glazing method shall be applicable. Gasketing to utilize: standard exterior glazing butyl tape completed with hard extruded shim and interior dense gasket extruded from Neoprene, EPDM or other equal material, as required. Gasket profile shall be designed and sized to uniformly fit tight and properly seal glass-metal interfacing. Acceptable gasket compression range to be 0.7 to 1.7 kN/m (4 – 10 lbs/in). Glass setting to be compatible with glass unit seals and/or other parts involved as required.

System Description - Framing System shall be 250, 350, 350T, 425T, 450, 450T, 460T - non-thermally broken/uninsulated (thermally broken/insulated - T), for single glass (sealed insulating glass units) METRO Series - Specifier selection - as manufactured by METRO ALUMINUM Products Ltd. Reference dimensions of extruded profiles shall be (Specifier's selection):
250 – 2.5" (63.5 mm) – Single & Double Stop – NTB
350 – 3.5" (88.9 mm) – Single & Double Stop – NTB
350T – 3.5" (88.9 mm) – Double Stop – TB
425T Tophat – 4.25" (107.9 mm) – Double Stop – TB
450 Tophat – 4.5" (114.3 mm) – Double Stop – NTB

450T Tophat – 4.5" (114.3 mm) – Double Stop – TB
460T Tophat – 6.25" (158.8 mm) – Double Stop – TB.
Where applicable, thermal break shall be polyurethane poured-in resin type.

Glass perimeter retention, as for wet-dry glazing method, shall be achieved by exterior glazing tape and interior glazing stop profile c/w inorganic rubber gasket. Glass hard bite to be 12.7 mm (0.5") minimum.

Whenever substitute/alternative products are considered, supporting data to be submitted ten (10) days prior to bid date to allow for valid comparison. Approval of alternates to be confirmed in advance of bid closing by addendum only.

Fabrication - Extruded profiles shall be accurately fabricated and assembled and sealed to provide air/water tight fit hairline joints only. Fastening shall allow for permanent true and square set of frame elements. Assembly shall utilize concealed screws only. Properly sealed frame assembly interfacing joints shall result in uninterrupted continuity of air barrier and compartmentization. Reference glazing system type to be one of the following (Specifier's selection):

Prime Seal – Exterior glazing shimmed tape and interior extruded rubber gasket,

Vented Cavity – As the above, plus heel bead with 4" returns at inner light, and weep holes as required,

Rain-Screen – As the above, plus heel bead at full perimeter at inner light, and weep holes as required.

Sill and head flashing shall be designed and fabricated to suit site conditions as required. Frame assemblies shall be free of warp. No exposed fasteners are permitted.

Finish - All exposed surfaces shall be finished as specified. The finish, as per AAM designation, shall be (Specifier's selection):

Standard clear anodizing to AA - M12C22A31

Standard perma bronze to AA - M12C22A44

Standard black anodizing to AA - M10C21A44

Duracron acrylic enamel to AA - M12C4XR1X

Custom paint qualities and colors - Specifier's selection.

Part 3 - EXECUTION

Installation – Anchoring shall suit perimeter conditions of rough openings and seals as required. Prefabricated/preglazed framing to be installed at prepared openings, at correct locations as shown on drawings, set level, plumb, square and aligned with other work in accordance with manufacturer's instructions, approved shop and erection drawings. Perimeter joints to be sealed/caulked as specified and detailed to ensure weathertight assembly.

Protection and Cleaning - Work to be protected from damage during and after installation. Consult with manufacturer and installer to determine appropriate protective measures. The General Contractor shall be responsible for protection during construction and for final cleaning. After installation, aluminum work and glass to be cleaned according to instructions/manuals provided by product manufacturers and glaziers. Use appropriate cleaning materials and methods. Do not scratch or damage glass or finishes.

COMPONENTS

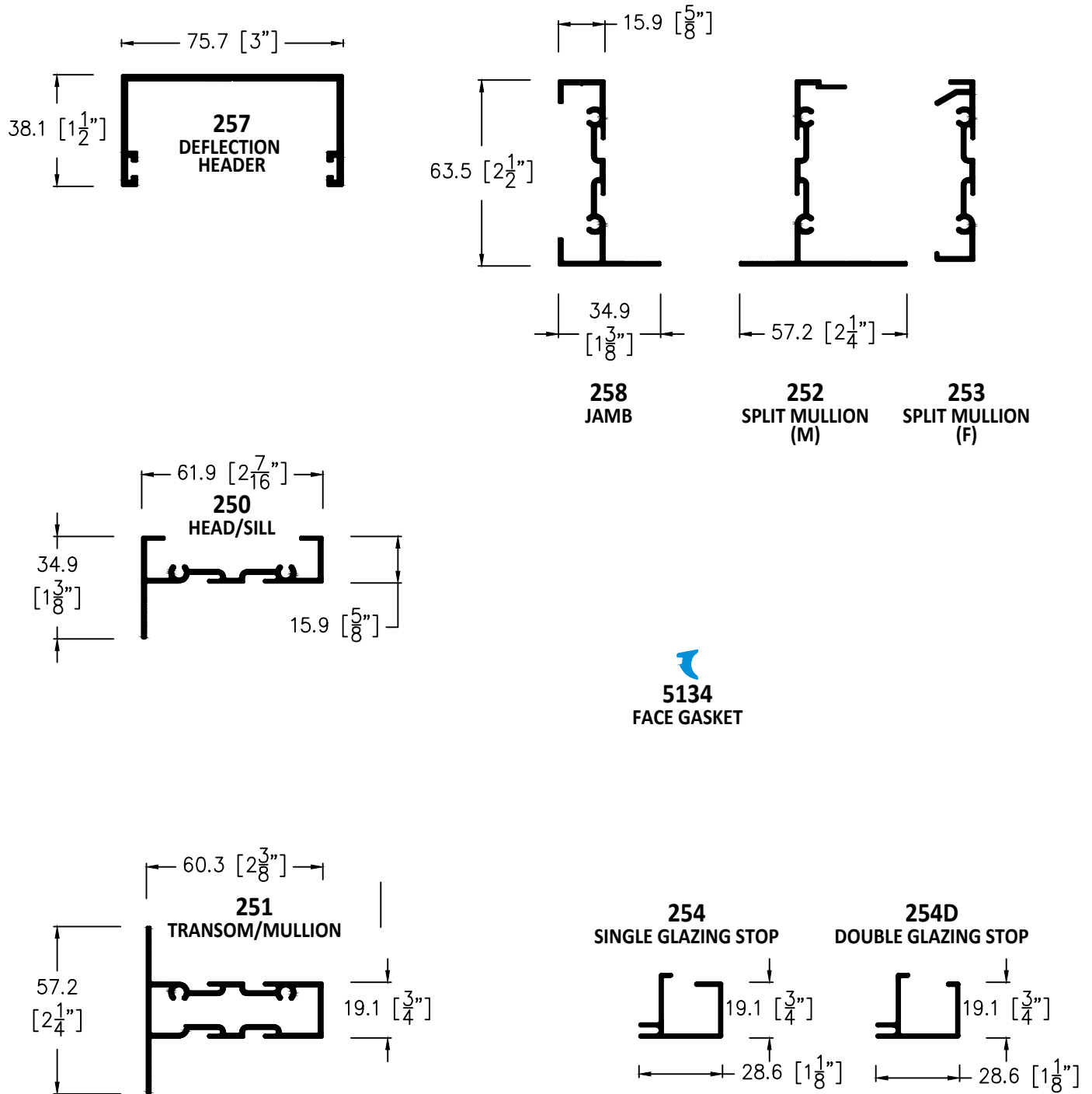



**METRO
ALUMINUM**
Products Ltd.

250 SERIES

FIXED WINDOW SYSTEM
2 1/2" (63.5 mm)

**E
03**

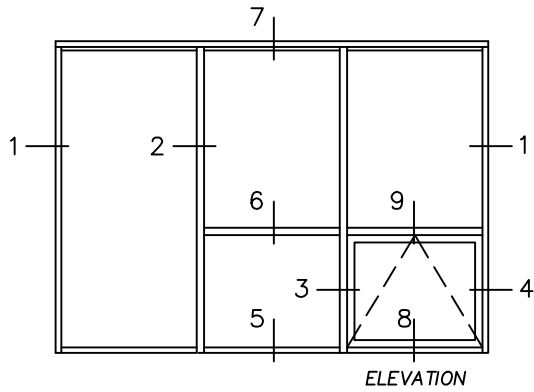

DETAILS

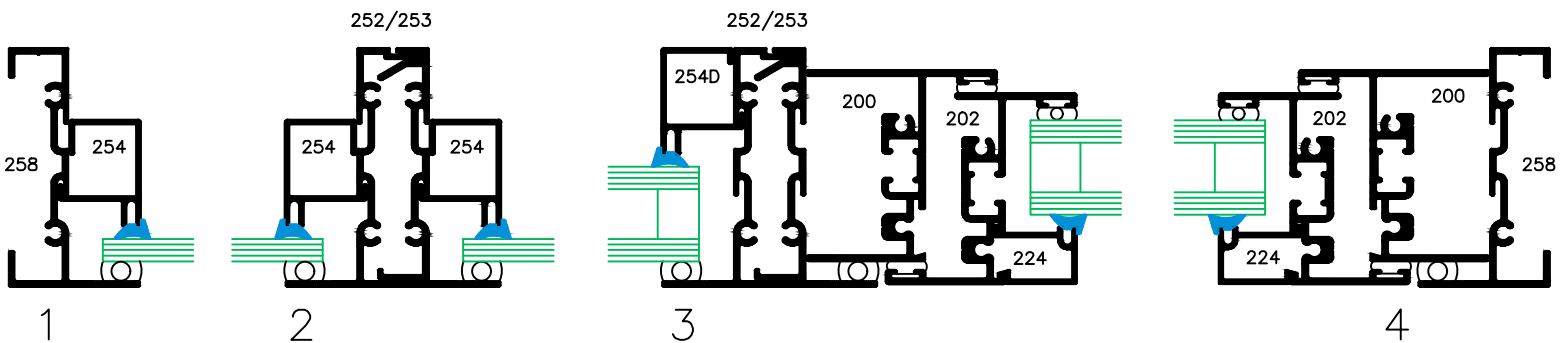
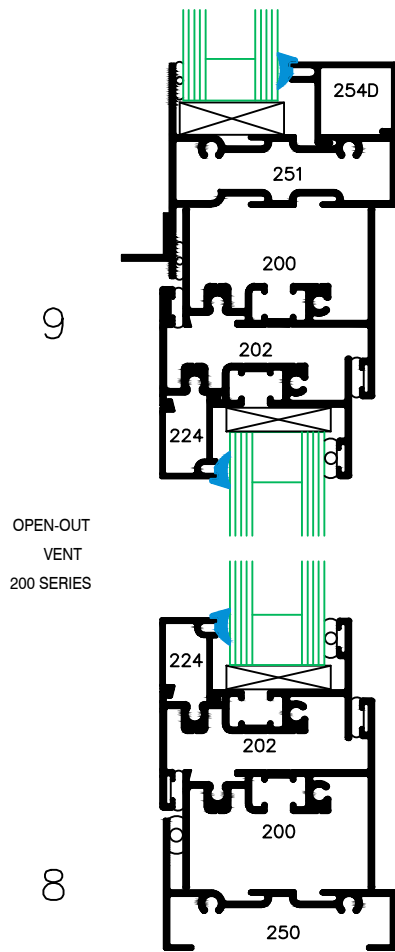
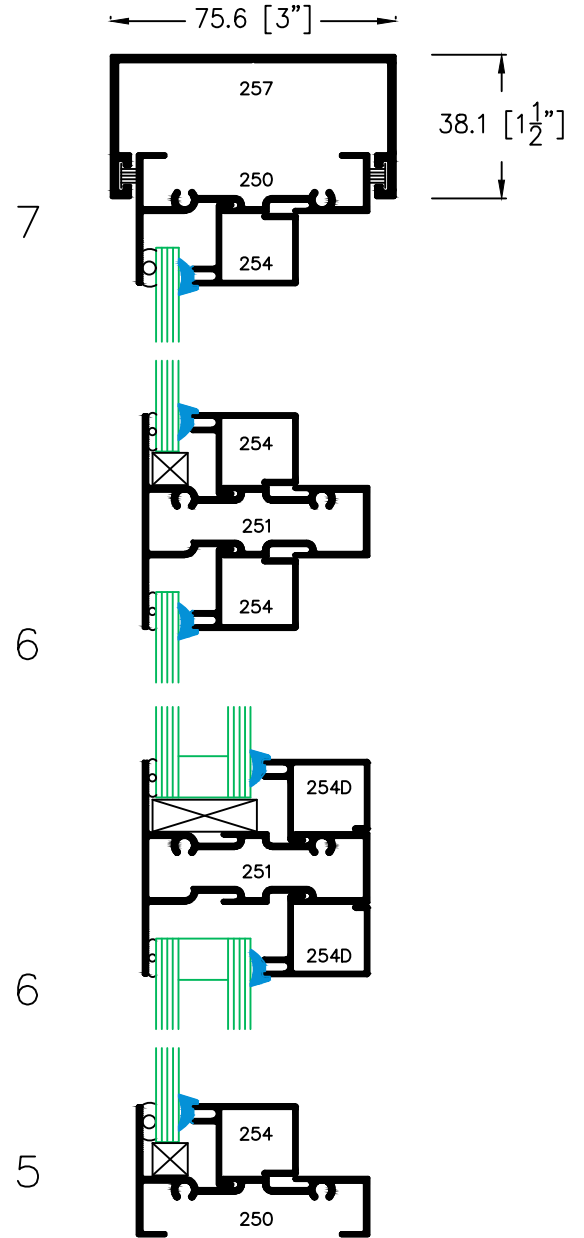

WIND LOAD CHART FOR 250 SERIES - PART # 252/253

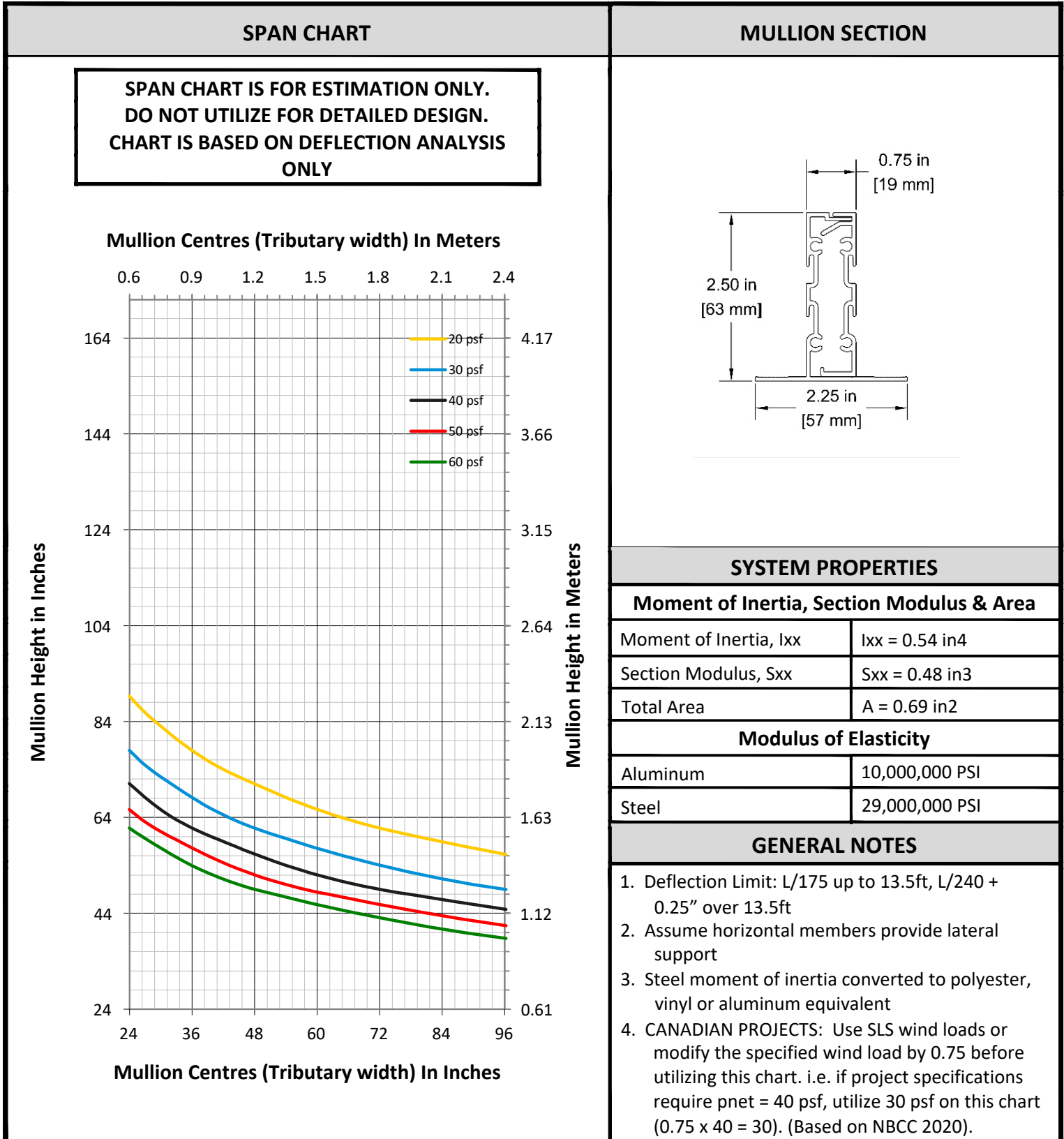

DEAD LOAD CHART FOR 250 SERIES - PART # 251

SPAN CHART

**SPAN CHART IS FOR ESTIMATION ONLY.
DO NOT UTILIZE FOR DETAILED DESIGN.
CHART IS BASED ON DEFLECTION ANALYSIS
ONLY**

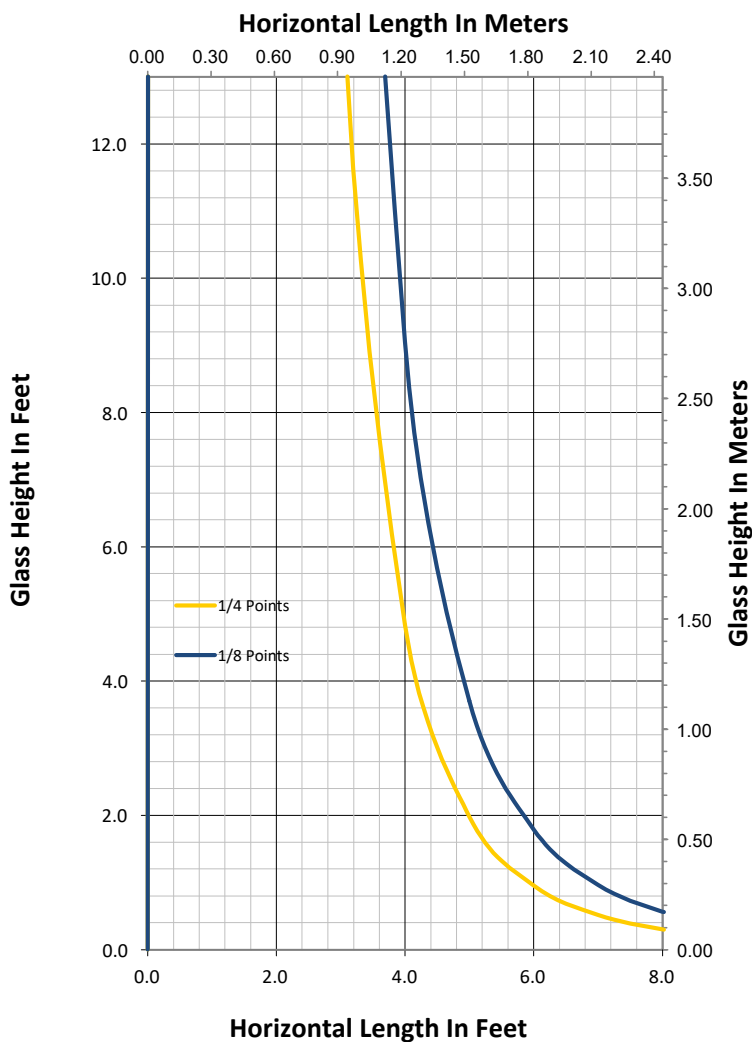

MULLION SECTION

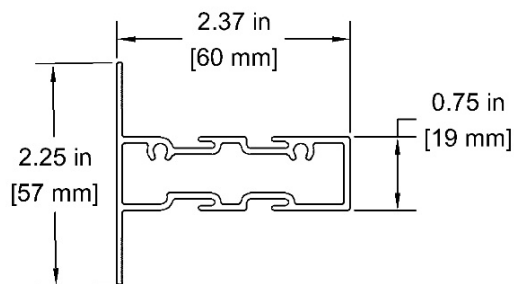

SYSTEM PROPERTIES

Moment of Inertia, Section Modulus & Area

Moment of Inertia, I_{yy}	$I_{yy} = 0.15 \text{ in}^4$
Section Modulus, S_{yy}	$S_{yy} = 0.13 \text{ in}^3$
Total Area	$A = 2.82 \text{ in}^2$

Modulus of Elasticity

Aluminum	10,000,000 PSI
Steel	29,000,000 PSI

GENERAL NOTES

1. Deflection Limit: 0.125" (3.2mm).
2. Charts are calculated assuming a 1" overall sealed unit (6mm/13mm spacer/6mm)
3. Calculations are based on the position of the setting blocks being placed at 1/4 or 1/8 points.



COMPONENTS

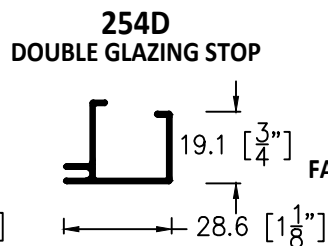
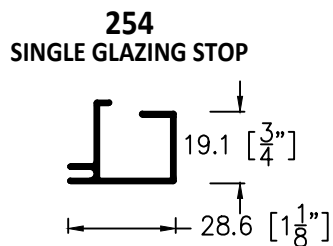
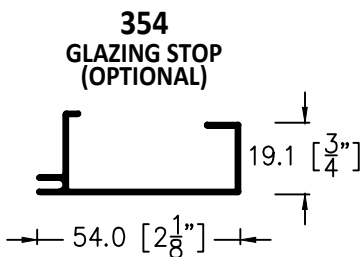
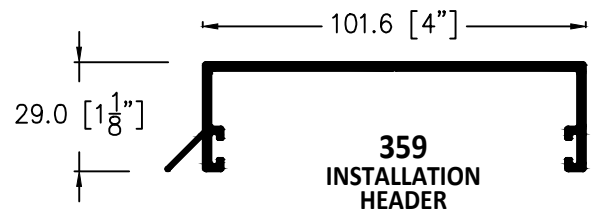
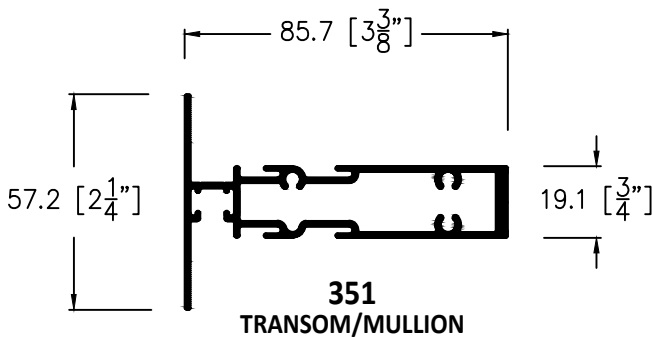
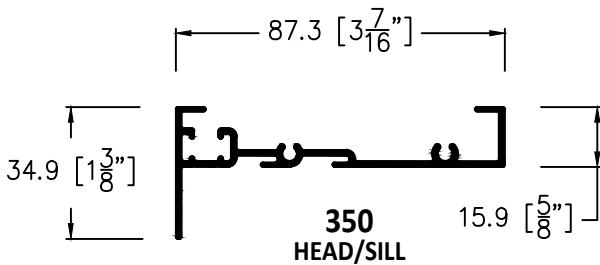
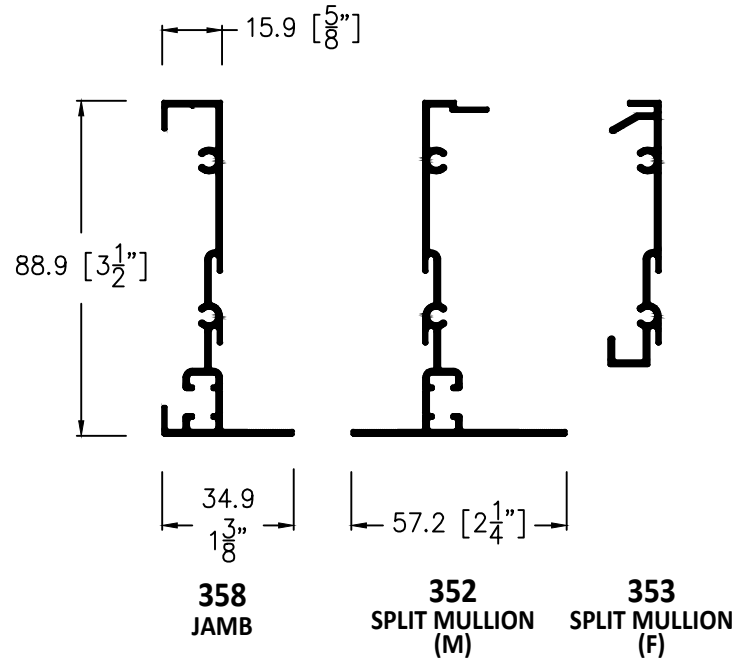
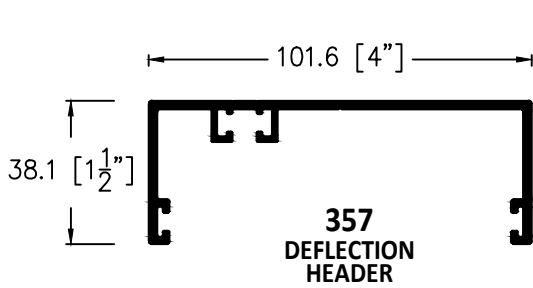

DETAILS

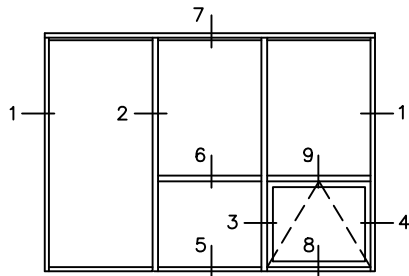

ELEVATION

2 OPTIONAL
GLAZING

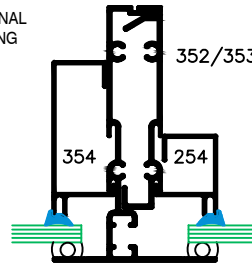

4 OPEN-IN
VENT

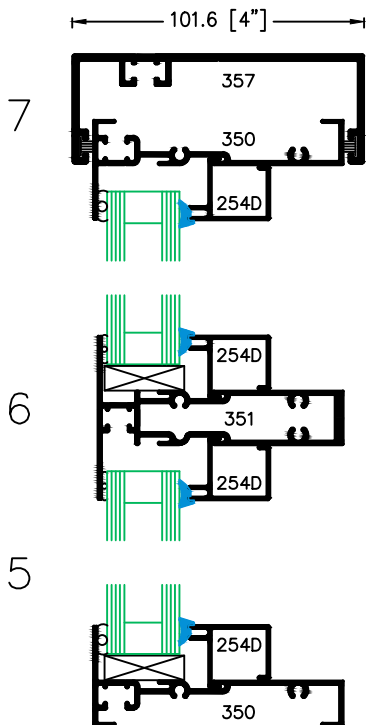
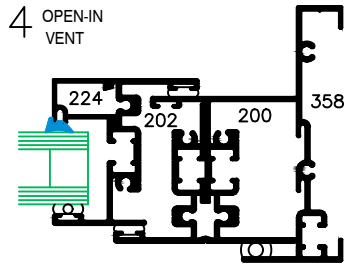

9

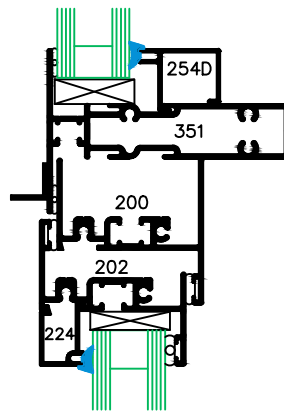

OPEN-OUT
VENT
200 SERIES

9

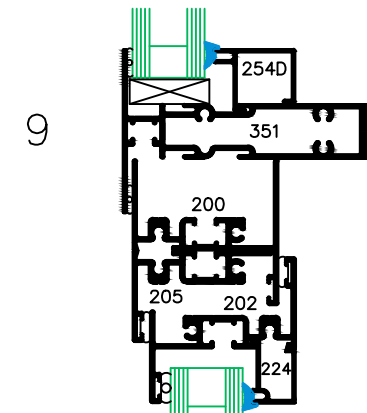

OPEN-IN
VENT
200 SERIES

8

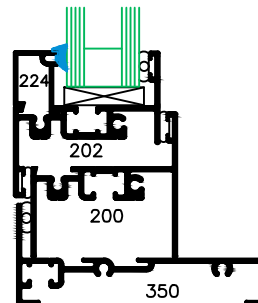

8

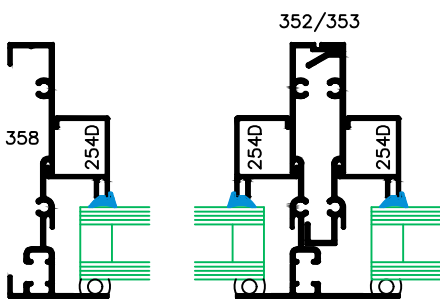
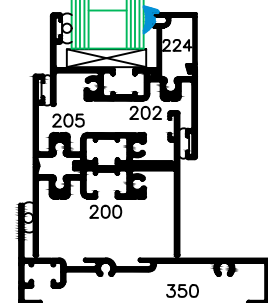

1

2

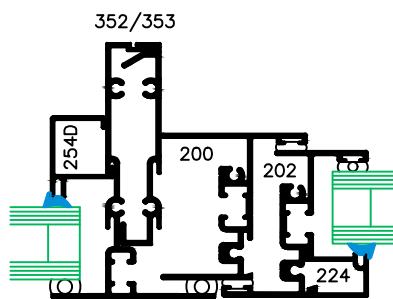

3

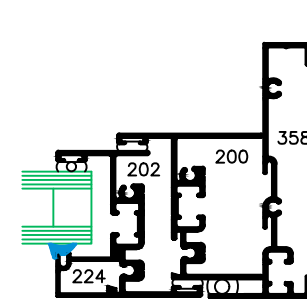

4

WIND LOAD CHART FOR 350 SERIES - PART # 352/353

SPAN CHART

SPAN CHART IS FOR ESTIMATION ONLY.
DO NOT UTILIZE FOR DETAILED DESIGN.
CHART IS BASED ON DEFLECTION ANALYSIS
ONLY

Mullion Centres (Tributary width) In Meters

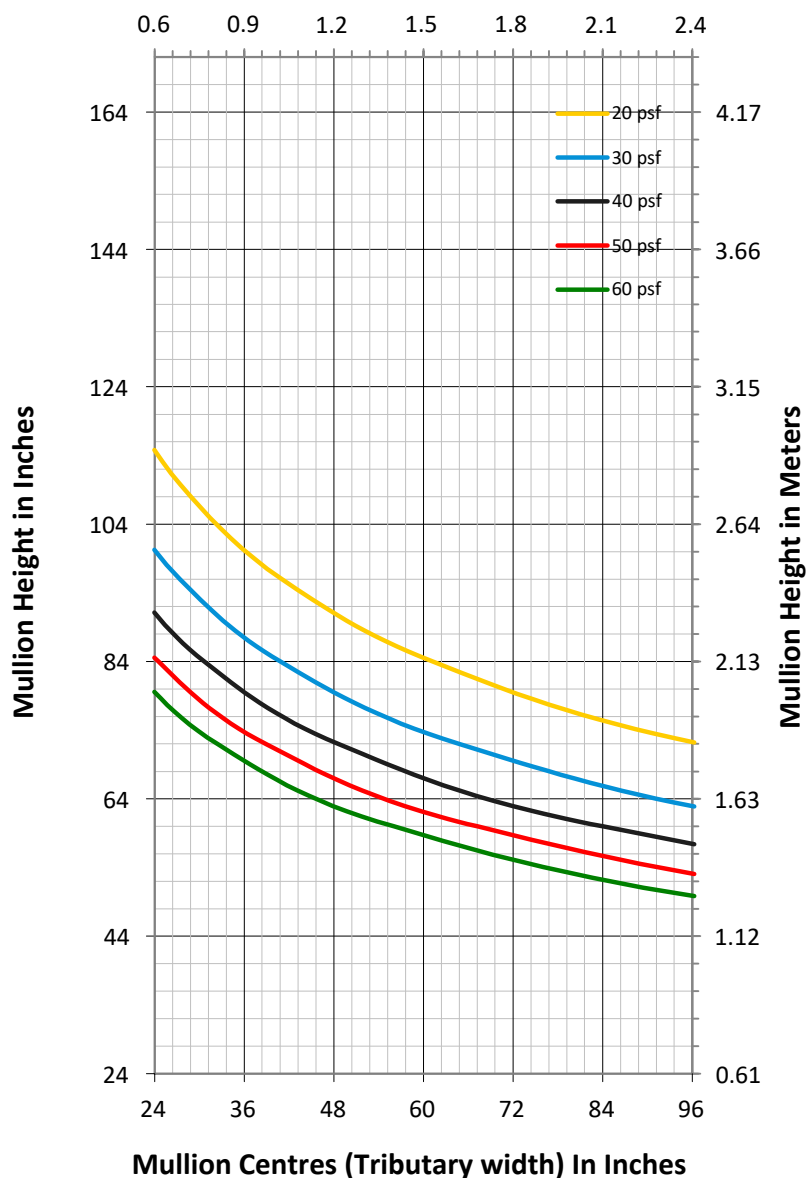

MULLION SECTION

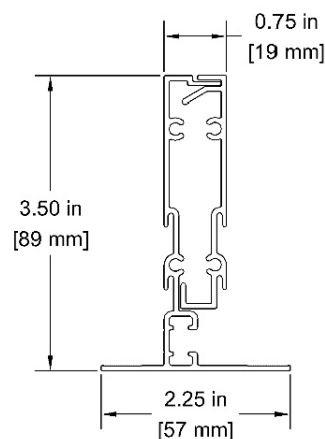

SYSTEM PROPERTIES

Moment of Inertia, Section Modulus & Area

Moment of Inertia, I_{xx}	$I_{xx} = 1.15 \text{ in}^4$
Section Modulus, S_{xx}	$S_{xx} = 0.61 \text{ in}^3$
Total Area	$A = 0.82 \text{ in}^2$

Modulus of Elasticity

Aluminum	10,000,000 PSI
Steel	29,000,000 PSI

GENERAL NOTES

1. Deflection Limit: $L/175$ up to 13.5ft, $L/240 + 0.25"$ over 13.5ft
2. Assume horizontal members provide lateral support
3. Steel moment of inertia converted to polyester, vinyl or aluminum equivalent
4. CANADIAN PROJECTS: Use SLS wind loads or modify the specified wind load by 0.75 before utilizing this chart. i.e. if project specifications require $p_{net} = 40 \text{ psf}$, utilize 30 psf on this chart ($0.75 \times 40 = 30$). (Based on NBCC 2020).

DEAD LOAD CHART FOR 350 SERIES - PART # 351

SPAN CHART

SPAN CHART IS FOR ESTIMATION ONLY.
DO NOT UTILIZE FOR DETAILED DESIGN.
CHART IS BASED ON DEFLECTION ANALYSIS
ONLY

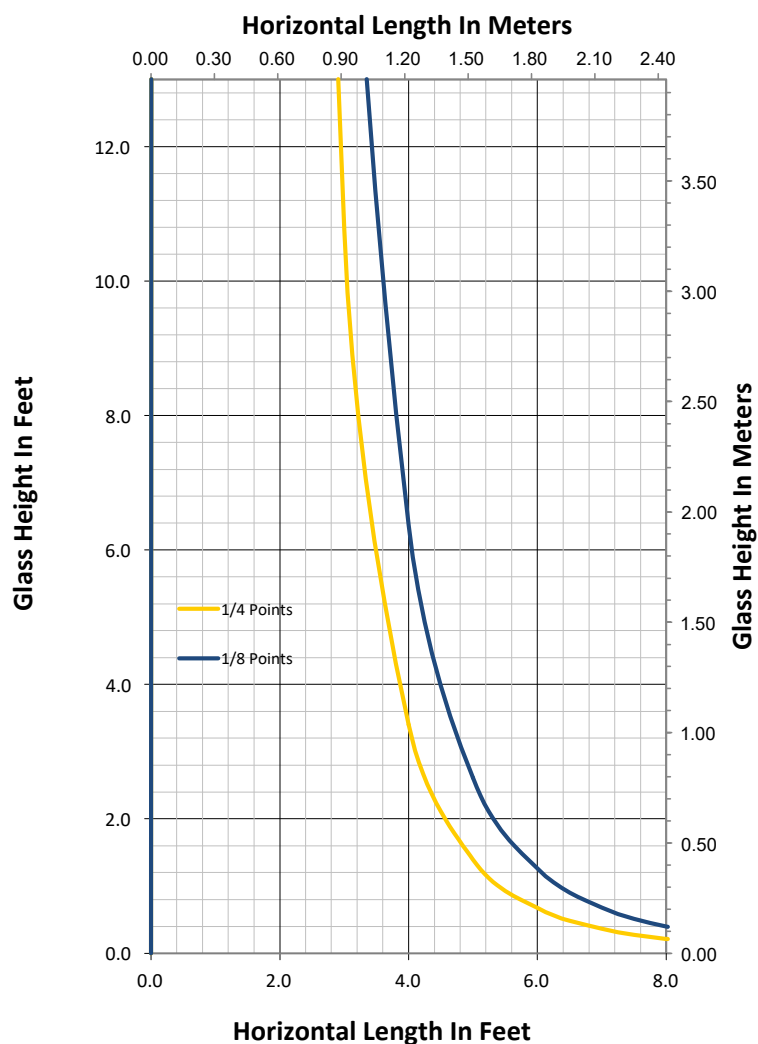

MULLION SECTION

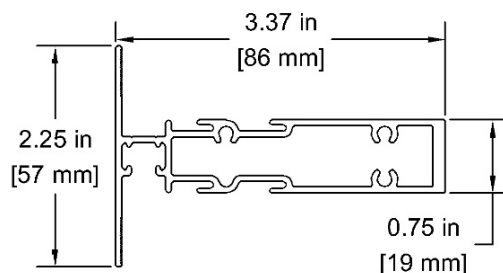

SYSTEM PROPERTIES

Moment of Inertia, Section Modulus & Area

Moment of Inertia, I_{yy}	$I_{yy} = 0.10 \text{ in}^4$
Section Modulus, S_{yy}	$S_{yy} = 0.09 \text{ in}^3$
Total Area	$A = 0.78 \text{ in}^2$

Modulus of Elasticity

Aluminum	10,000,000 PSI
Steel	29,000,000 PSI

GENERAL NOTES

1. Deflection Limit: 0.125" (3.2mm).
2. Charts are calculated assuming a 1" overall sealed unit (6mm/13mm spacer/6mm)
3. Calculations are based on the position of the setting blocks being placed at 1/4 or 1/8 points.





COMPONENTS

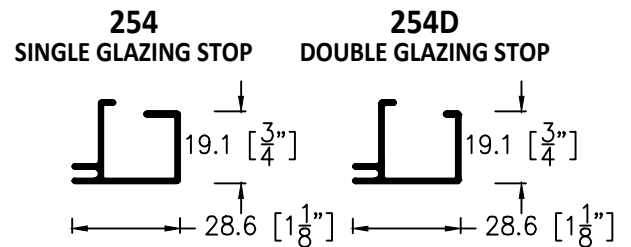
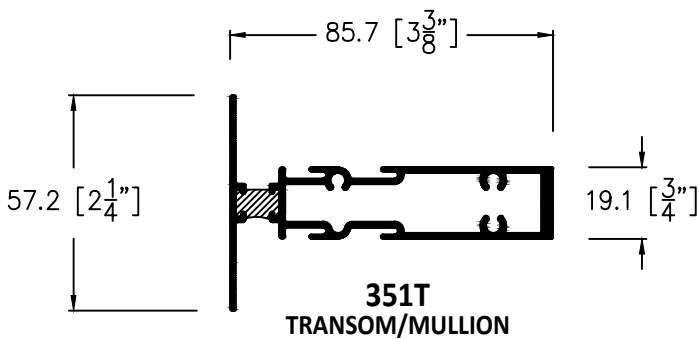
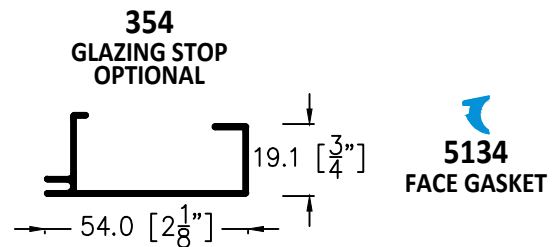
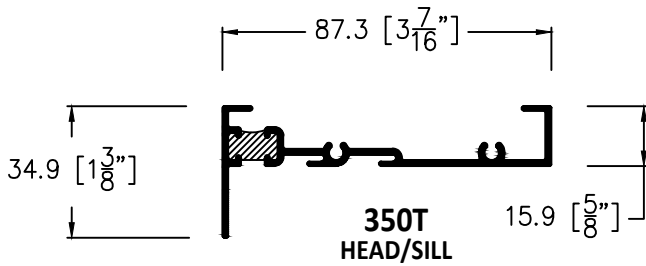
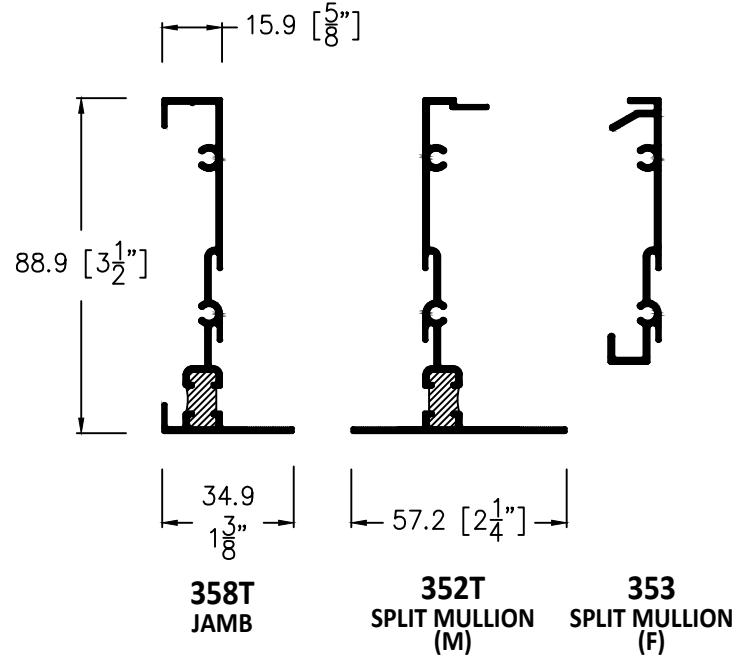
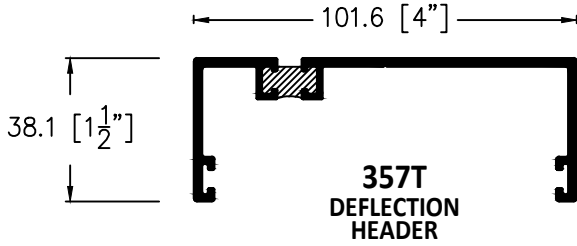

DETAILS

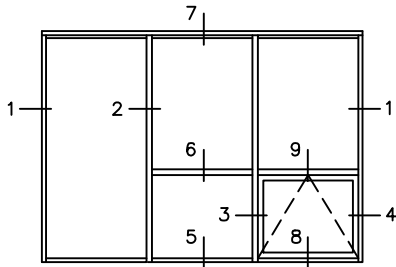

ELEVATION

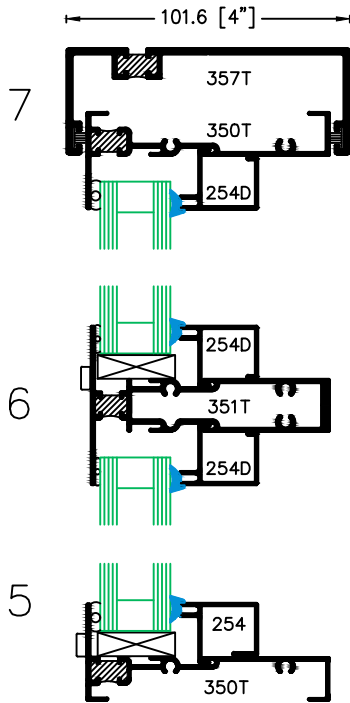
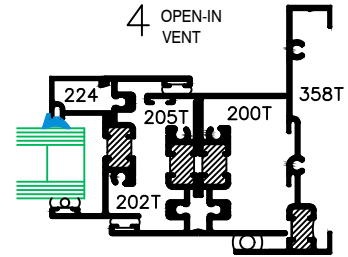

RAIN SCREEN APPLICATION

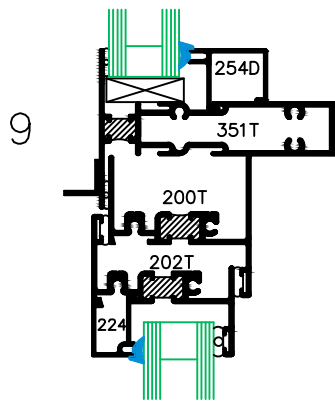

OPEN-OUT VENT
200T SERIES

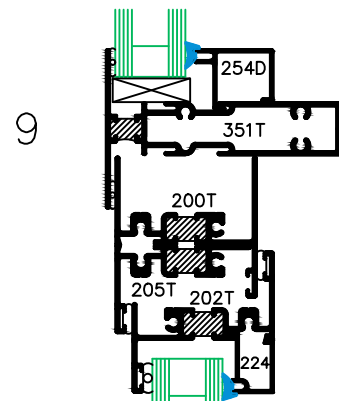

OPEN-IN VENT
200T SERIES

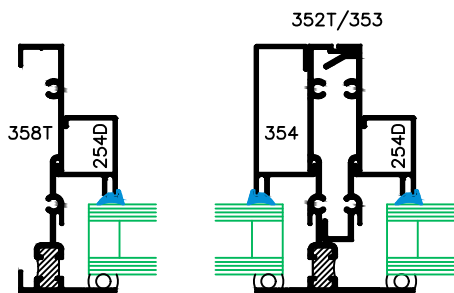
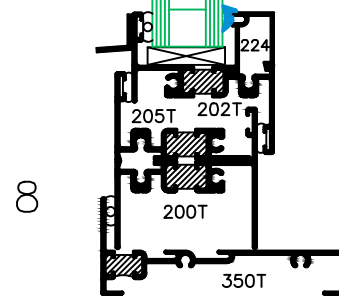
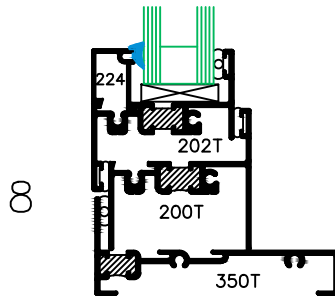

1 2 OPTIONAL STOPS

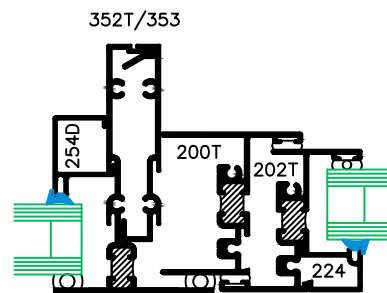

3

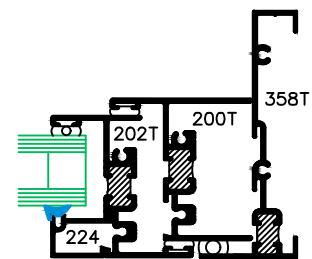

4

WIND LOAD CHART FOR 350T SERIES - PART # 352T/353

SPAN CHART

SPAN CHART IS FOR ESTIMATION ONLY.
DO NOT UTILIZE FOR DETAILED DESIGN.
CHART IS BASED ON DEFLECTION ANALYSIS
ONLY

Mullion Centres (Tributary width) In Meters

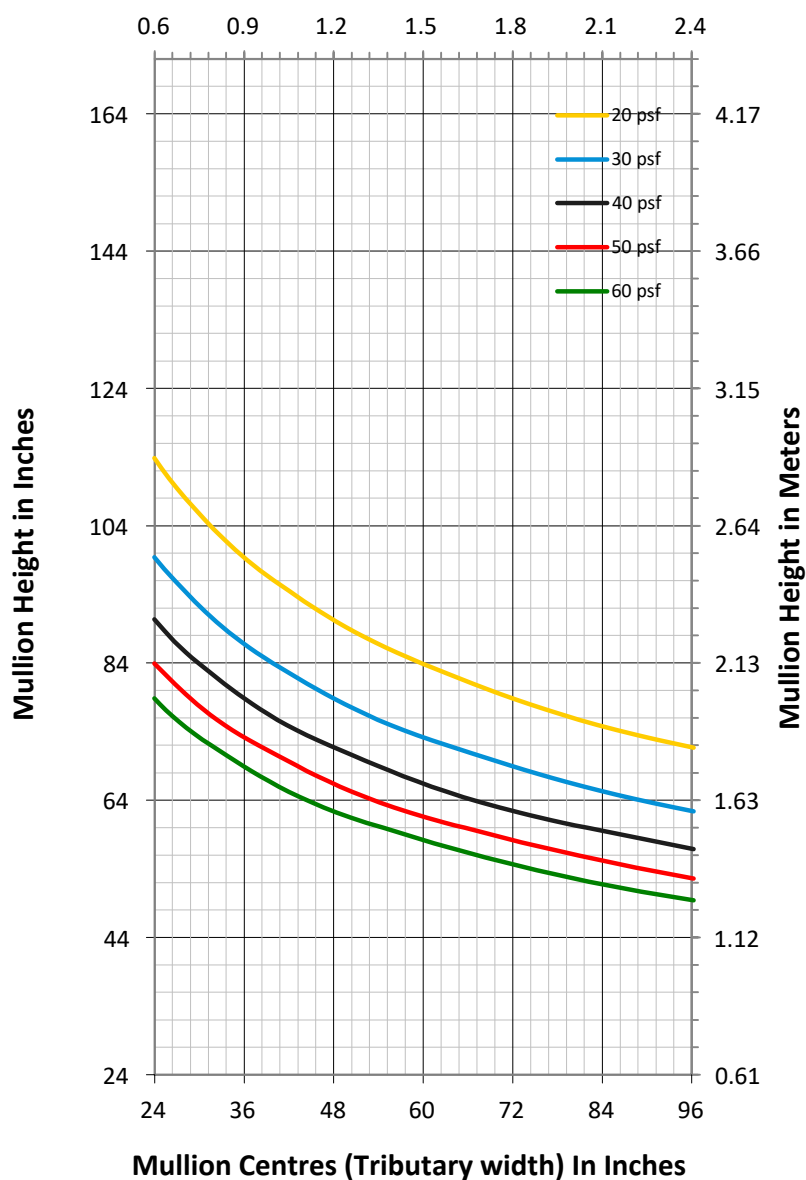

MULLION SECTION

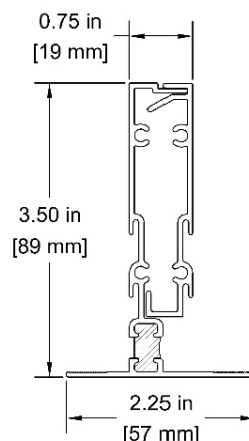

SYSTEM PROPERTIES

Moment of Inertia, Section Modulus & Area

Moment of Inertia, I _{xx}	I _{xx} = 1.12 in ⁴
Section Modulus, S _{xx}	S _{xx} = 0.39 in ³
Total Area	A = 0.80 in ²

Modulus of Elasticity

Aluminum	10,000,000 PSI
Steel	29,000,000 PSI

GENERAL NOTES

1. Deflection Limit: L/175 up to 13.5ft, L/240 + 0.25" over 13.5ft
2. Assume horizontal members provide lateral support
3. Steel moment of inertia converted to polyester, vinyl or aluminum equivalent
4. CANADIAN PROJECTS: Use SLS wind loads or modify the specified wind load by 0.75 before utilizing this chart. i.e. if project specifications require pnet = 40 psf, utilize 30 psf on this chart (0.75 x 40 = 30). (Based on NBCC 2020).

DEAD LOAD CHART FOR 350T SERIES - PART # 351T

SPAN CHART

SPAN CHART IS FOR ESTIMATION ONLY.
DO NOT UTILIZE FOR DETAILED DESIGN.
CHART IS BASED ON DEFLECTION ANALYSIS
ONLY

MULLION SECTION

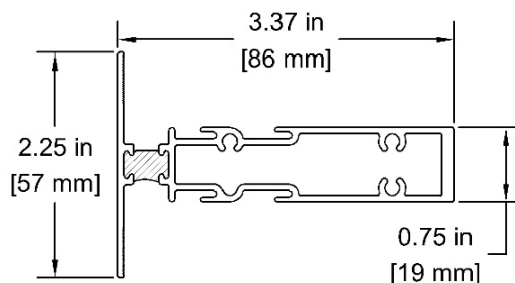

SYSTEM PROPERTIES

Moment of Inertia, Section Modulus & Area

Moment of Inertia, I_{yy}	$I_{yy} = 0.10 \text{ in}^4$
Section Modulus, S_{yy}	$S_{yy} = 0.13 \text{ in}^3$
Total Area	$A = 0.76 \text{ in}^2$

Modulus of Elasticity

Aluminum	10,000,000 PSI
Steel	29,000,000 PSI

GENERAL NOTES

1. Deflection Limit: 0.125" (3.2mm).
2. Charts are calculated assuming a 1" overall sealed unit (6mm/13mm spacer/6mm)
3. Calculations are based on the position of the setting blocks being placed at 1/4 or 1/8 points.

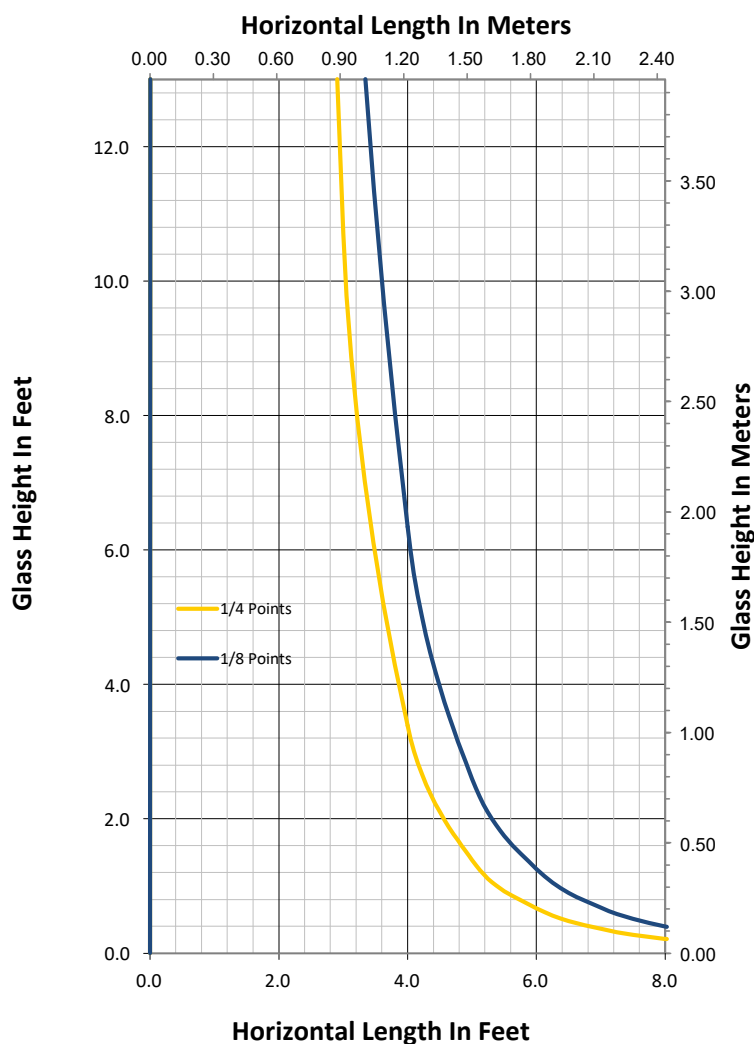





COMPONENTS

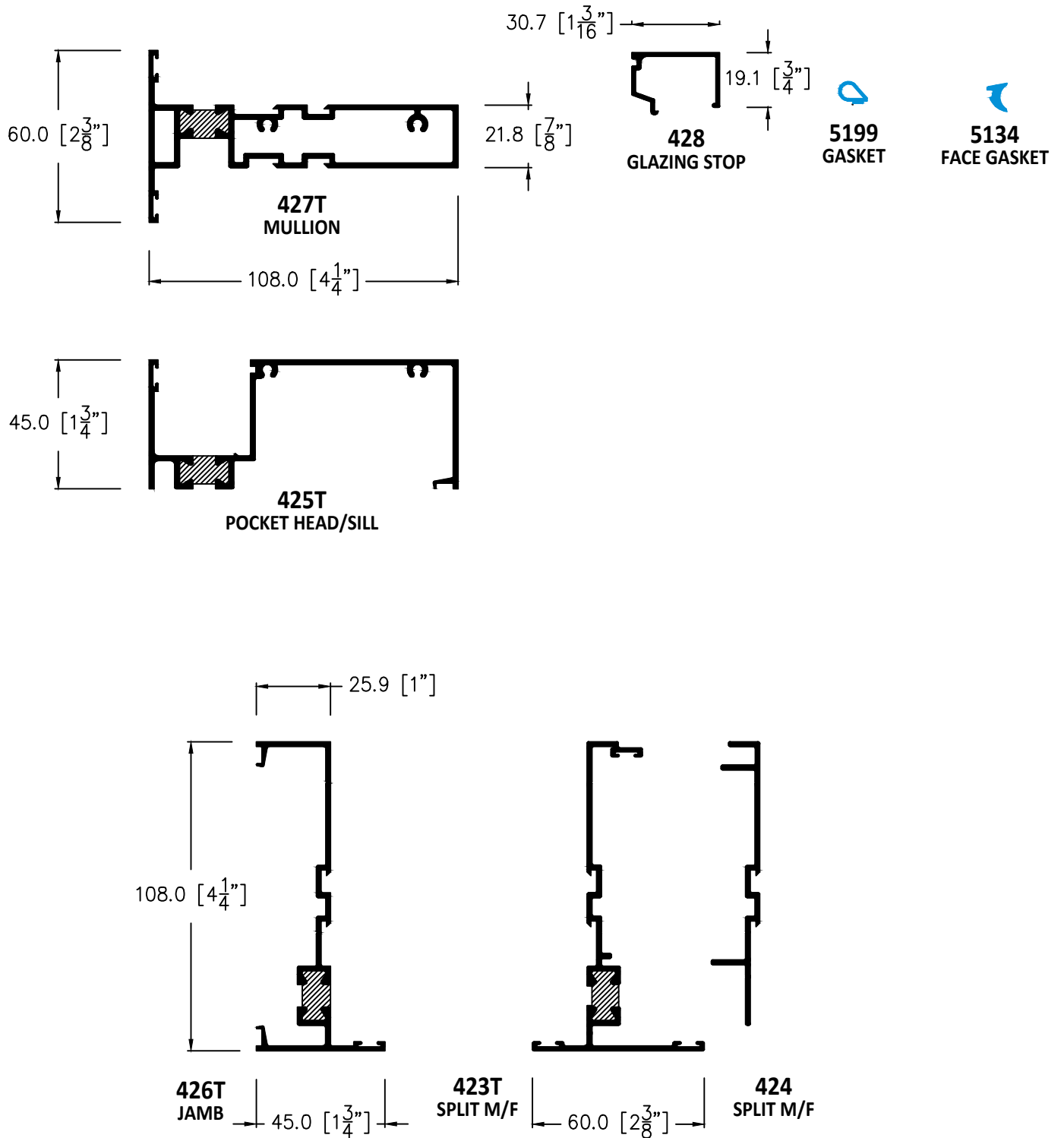

DETAILS

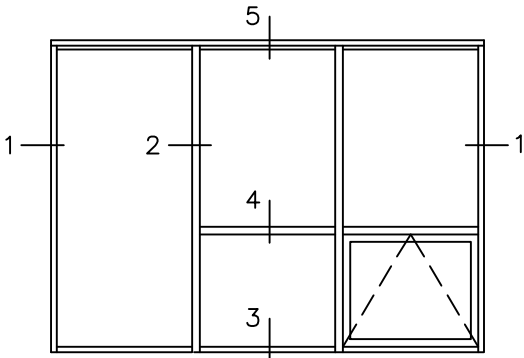

ELEVATION

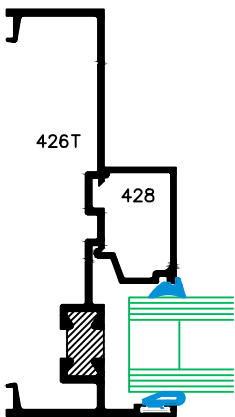
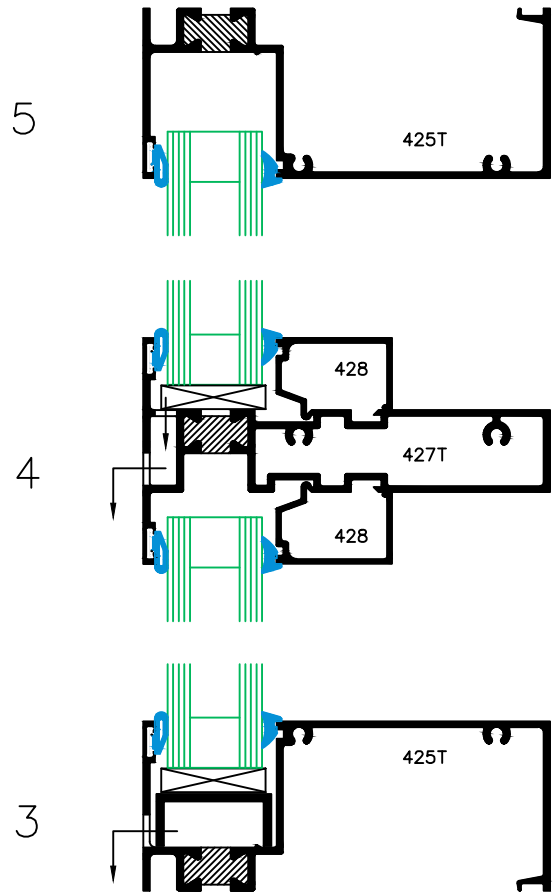

1

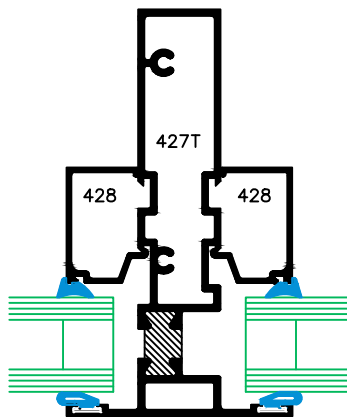

2

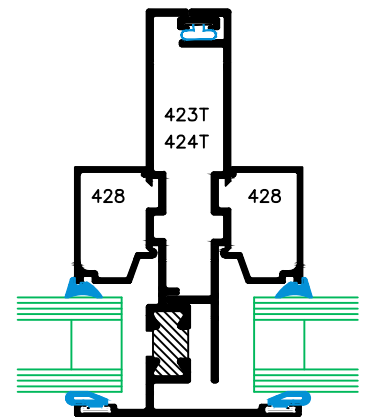

2

WIND LOAD CHART FOR 425T SERIES - PART # 423T/424

SPAN CHART

**SPAN CHART IS FOR ESTIMATION ONLY.
DO NOT UTILIZE FOR DETAILED DESIGN.
CHART IS BASED ON DEFLECTION ANALYSIS
ONLY**

Mullion Centres (Tributary width) In Meters

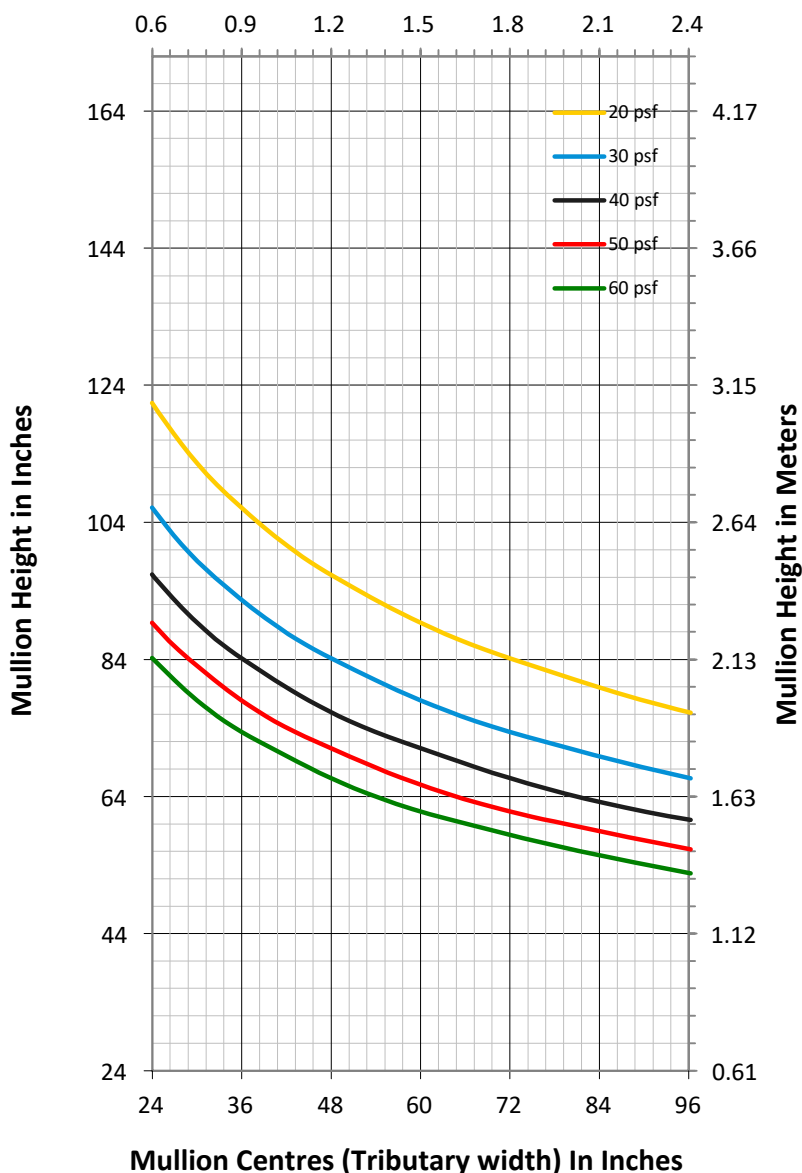

MULLION SECTION

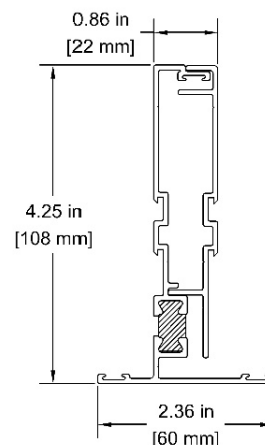

SYSTEM PROPERTIES

Moment of Inertia, Section Modulus & Area

Moment of Inertia, I _{xx}	I _{xx} = 1.36 in ⁴
Section Modulus, S _{xx}	S _{xx} = 0.29 in ³
Total Area	A = 0.62 in ²

Modulus of Elasticity

Aluminum	10,000,000 PSI
Steel	29,000,000 PSI

GENERAL NOTES

1. Deflection Limit: L/175 up to 13.5ft, L/240 + 0.25" over 13.5ft
2. Assume horizontal members provide lateral support
3. Steel moment of inertia converted to polyester, vinyl or aluminum equivalent
4. CANADIAN PROJECTS: Use SLS wind loads or modify the specified wind load by 0.75 before utilizing this chart. i.e. if project specifications require p_{net} = 40 psf, utilize 30 psf on this chart (0.75 x 40 = 30). (Based on NBCC 2020).

DEAD LOAD CHART FOR 425T SERIES - PART # 427T

SPAN CHART

SPAN CHART IS FOR ESTIMATION ONLY.
DO NOT UTILIZE FOR DETAILED DESIGN.
CHART IS BASED ON DEFLECTION ANALYSIS
ONLY

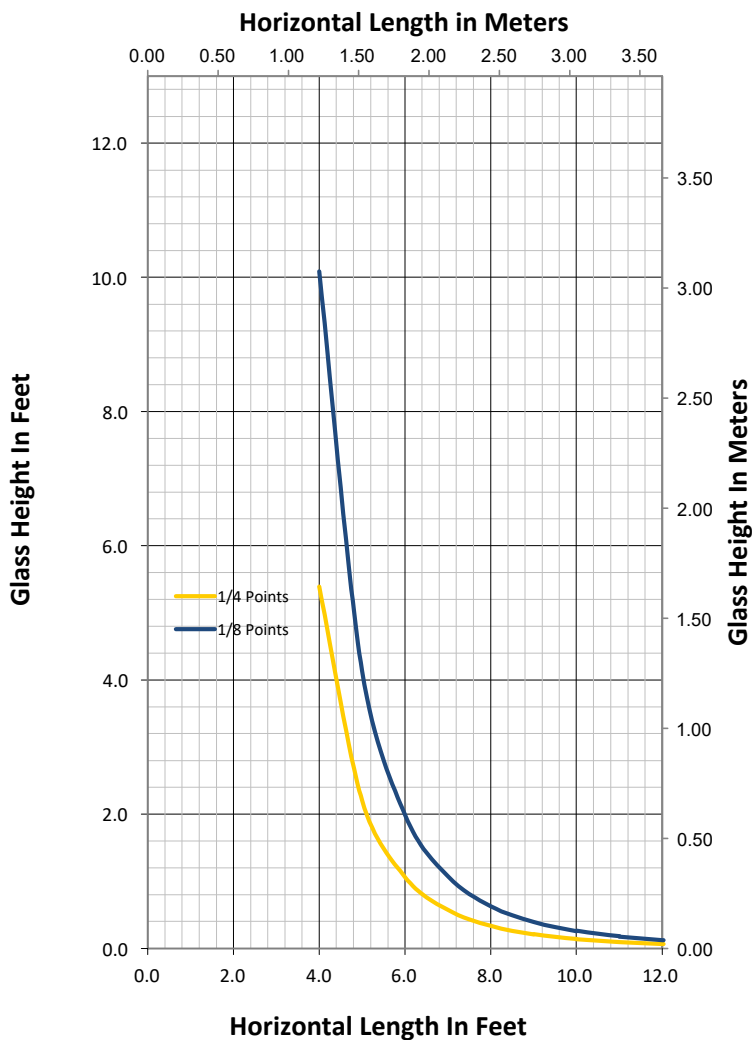

MULLION SECTION

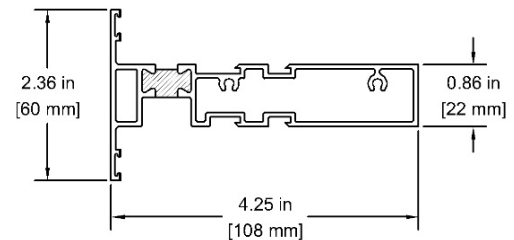

SYSTEM PROPERTIES

Moment of Inertia, Section Modulus & Area

Moment of Inertia, I_{yy}	$I_{yy} = 0.16 \text{ in}^4$
Section Modulus, S_{yy}	$S_{yy} = 0.14 \text{ in}^3$
Total Area	$A = 0.95 \text{ in}^2$

Modulus of Elasticity

Aluminum	10,000,000 PSI
Steel	29,000,000 PSI

GENERAL NOTES

1. Deflection Limit: 0.125" (3.2mm).
2. Charts are calculated assuming a 1" overall sealed unit (6mm/13mm spacer/6mm).
3. Calculations are based on the position of the setting blocks being placed at 1/4 or 1/8 points.



**METRO
ALUMINUM**

Products Ltd.

450 SERIES

FIXED WINDOW SYSTEM WITH
TOPHAT EXTENSION 4 1/2" (114.3 mm)

E





COMPONENTS

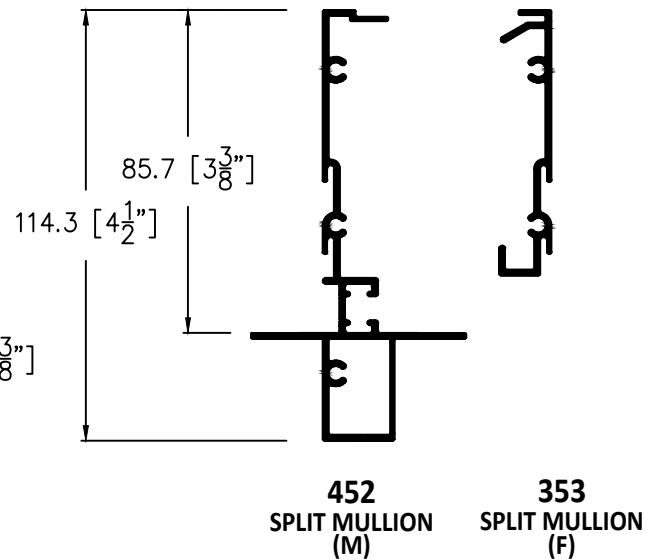
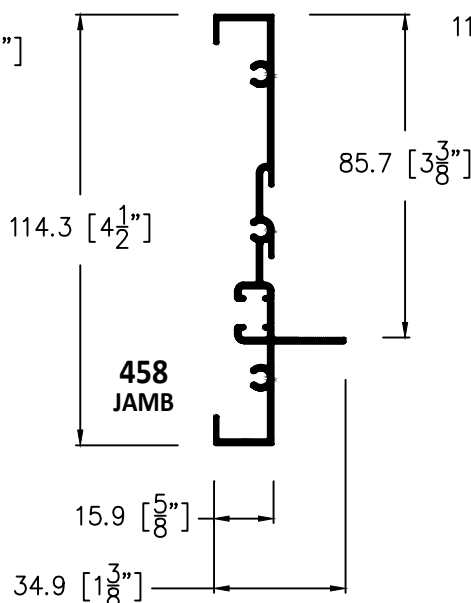
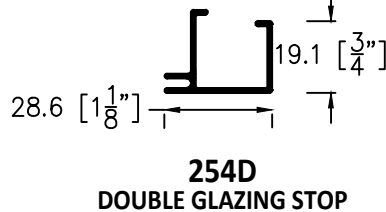
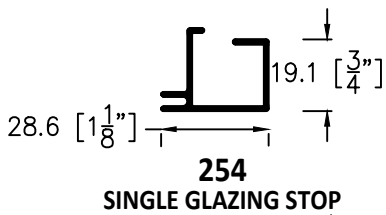
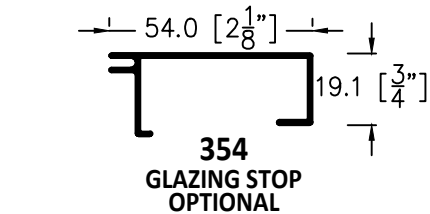
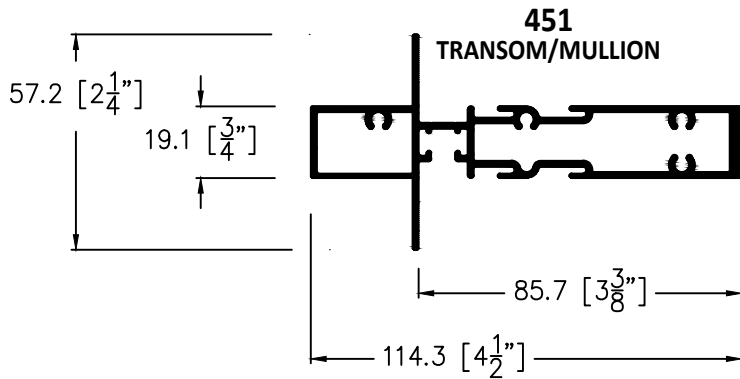
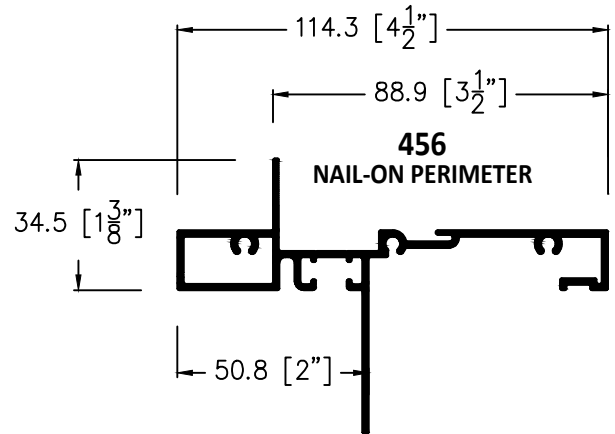
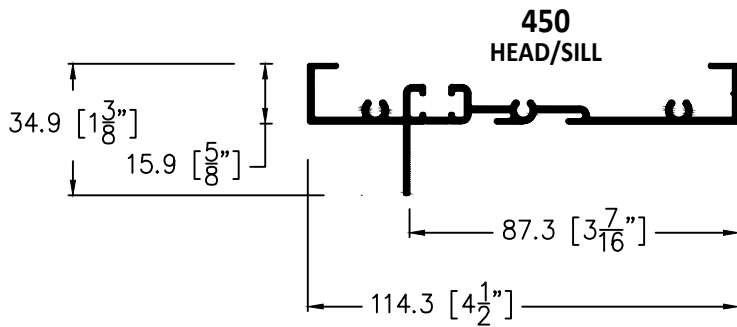
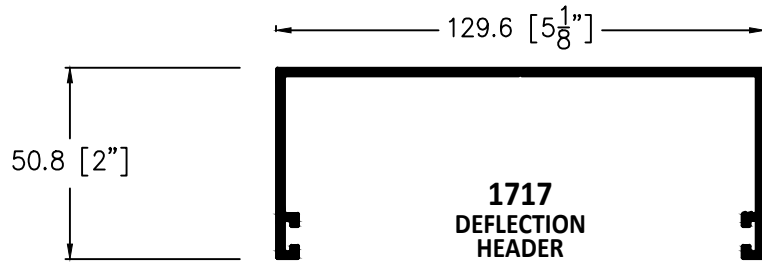



DETAILS

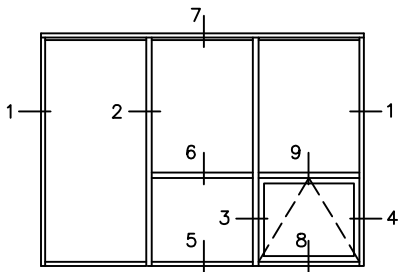

ELEVATION

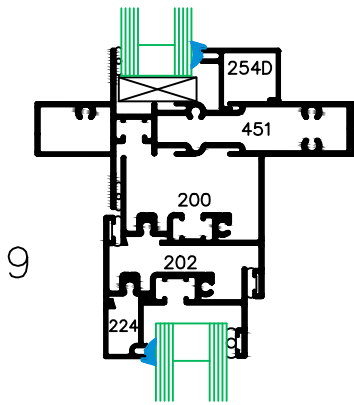
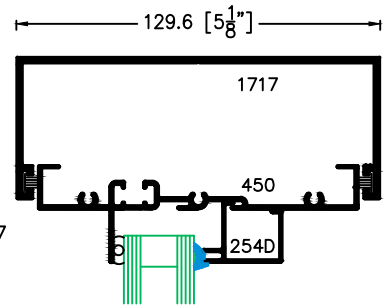

OPEN-OUT
VENT
200 SERIES

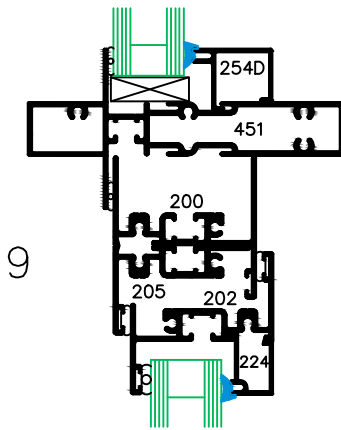

OPEN-IN
VENT
200 SERIES

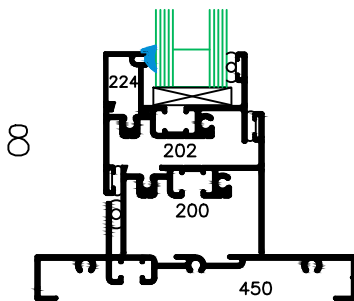
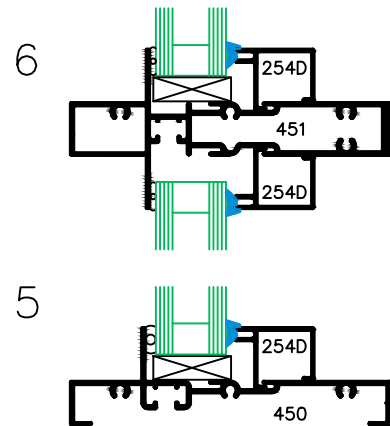

8

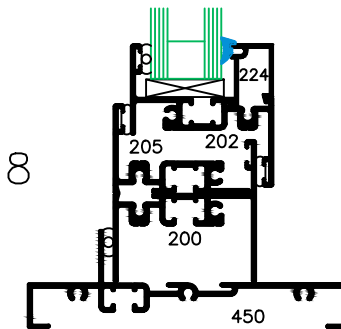

8

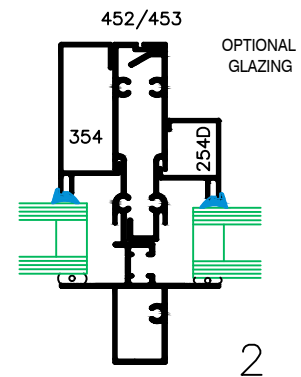

OPTIONAL
GLAZING

2

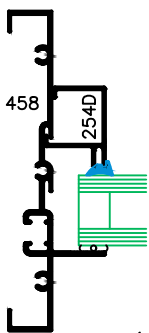

1

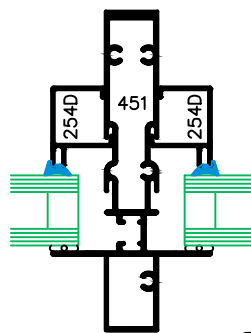

2

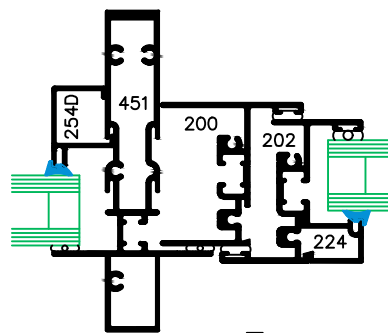

3

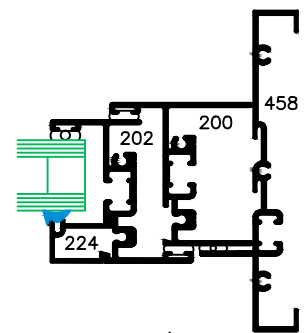

4

WIND LOAD CHART FOR 450 SERIES - PART # 452/353

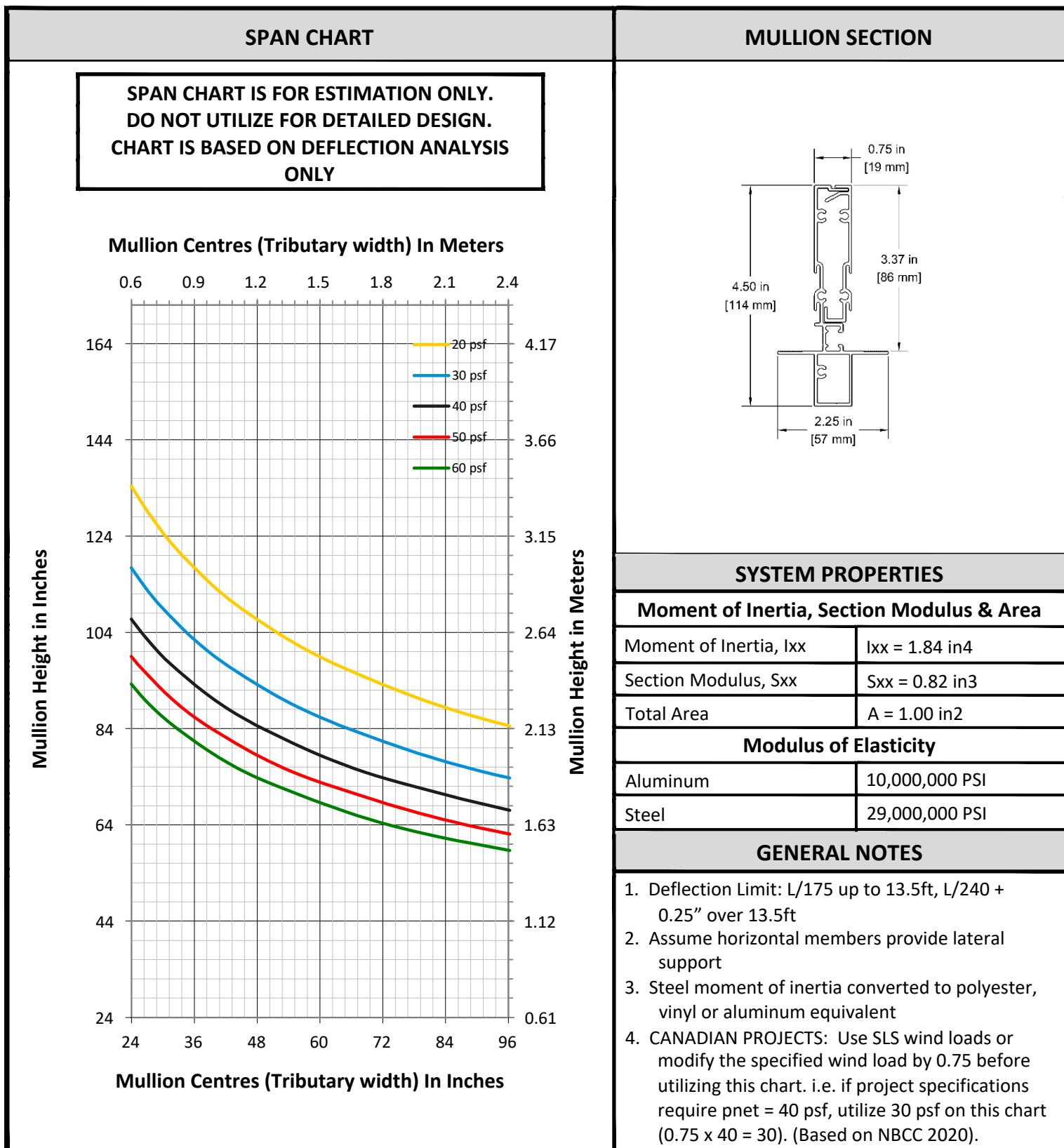

DEAD LOAD CHART FOR 450 SERIES - PART # 451

SPAN CHART

SPAN CHART IS FOR ESTIMATION ONLY.
DO NOT UTILIZE FOR DETAILED DESIGN.
CHART IS BASED ON DEFLECTION ANALYSIS
ONLY

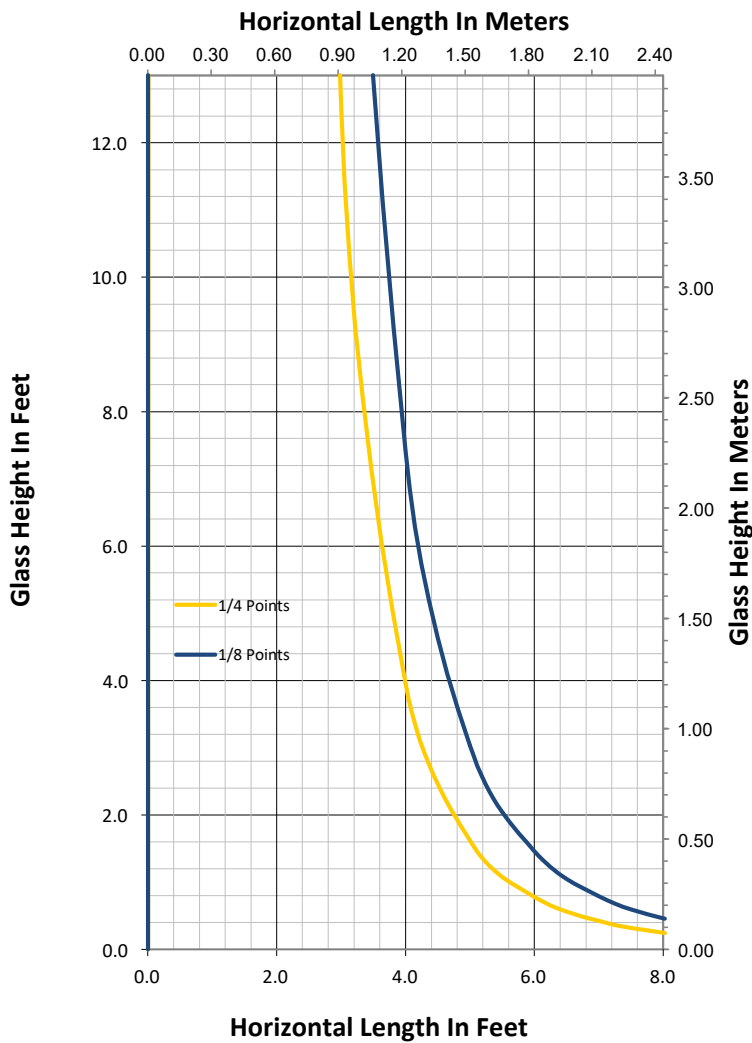

MULLION SECTION

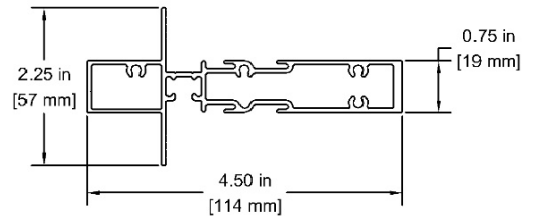

SYSTEM PROPERTIES

Moment of Inertia, Section Modulus & Area

Moment of Inertia, I_{yy}	$I_{yy} = 0.12 \text{ in}^4$
Section Modulus, S_{yy}	$S_{yy} = 0.11 \text{ in}^3$
Total Area	$A = 0.96 \text{ in}^2$

Modulus of Elasticity

Aluminum	10,000,000 PSI
Steel	29,000,000 PSI

GENERAL NOTES

1. Deflection Limit: 0.125" (3.2mm).
2. Charts are calculated assuming a 1" overall sealed unit (6mm/13mm spacer/6mm)
3. Calculations are based on the position of the setting blocks being placed at 1/4 or 1/8 points.



**METRO
ALUMINUM**

Products Ltd.

450T SERIES

T/B FIXED WINDOW SYSTEM WITH
TOPHAT EXTENSION 4 1/2" (114.3 mm)

E





COMPONENTS

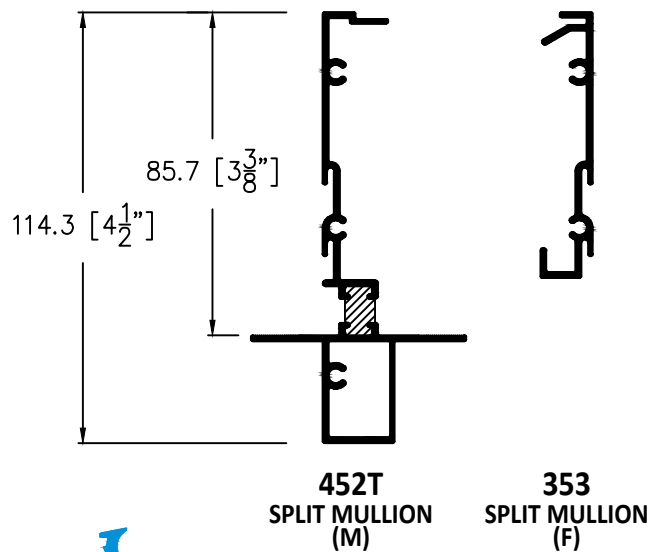
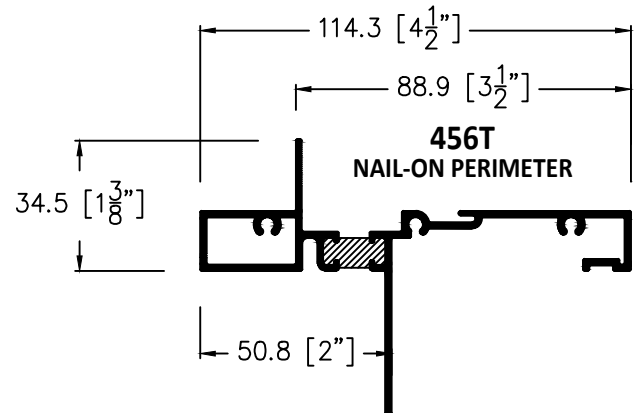
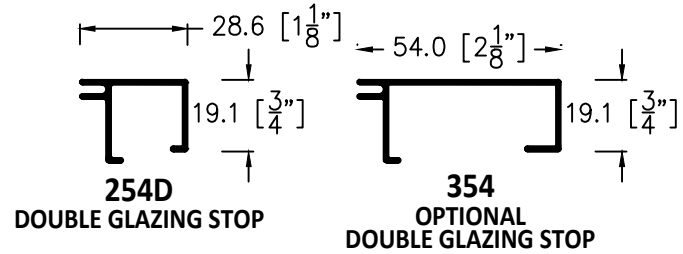
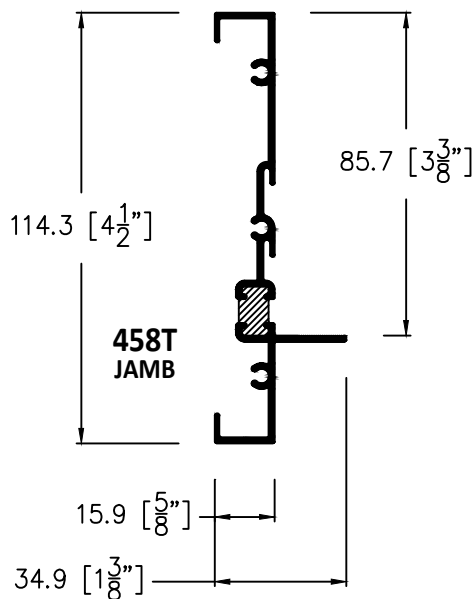
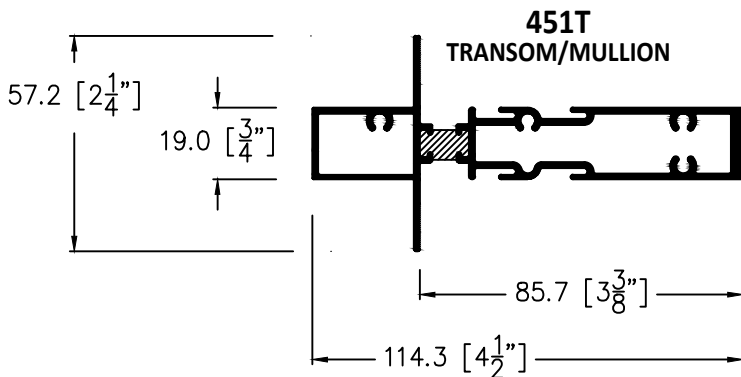
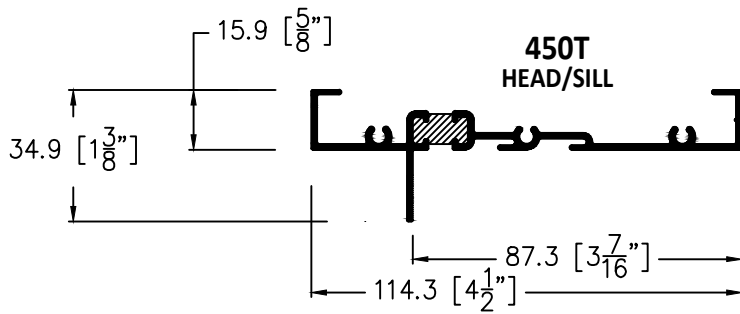
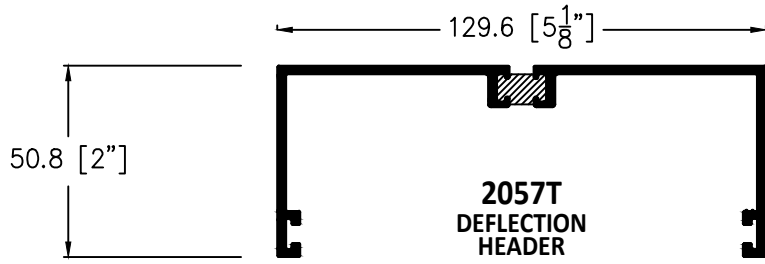

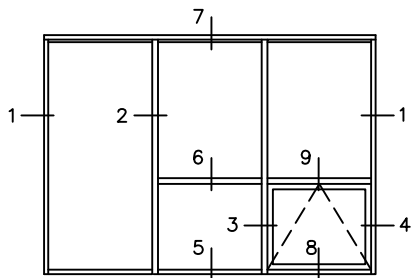

ELEVATION

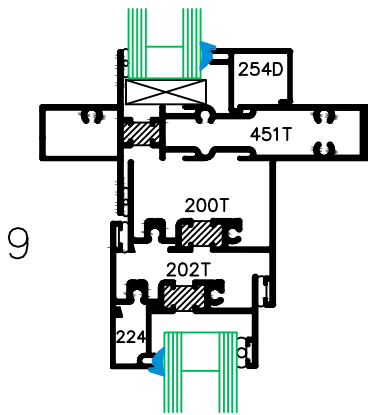

OPEN-OUT
VENT
200T SERIES

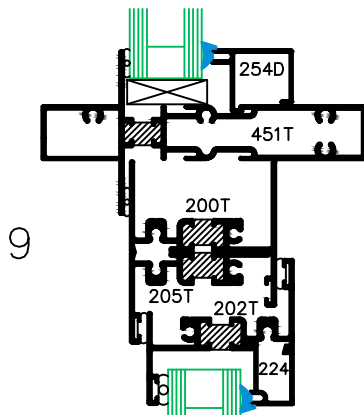

OPEN-IN
VENT
200T SERIES

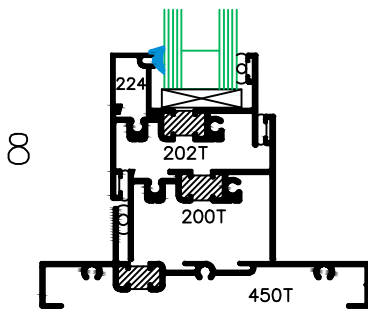

8

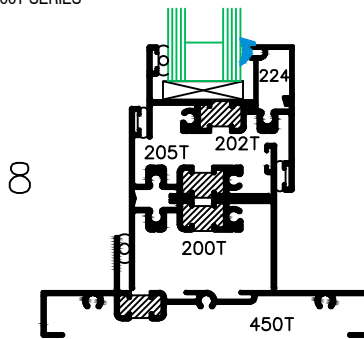

8

DETAILS

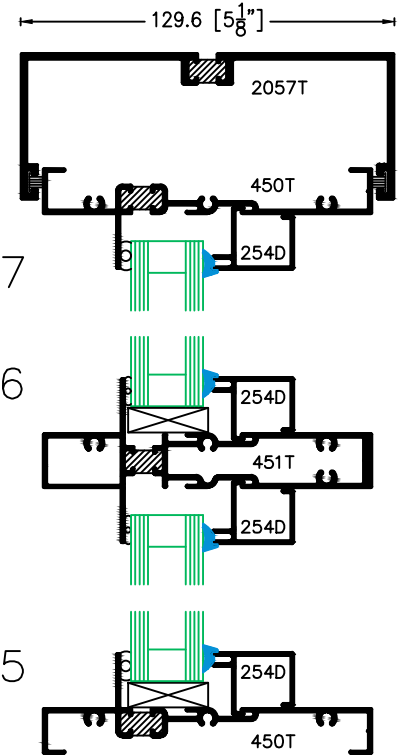

7

6

5

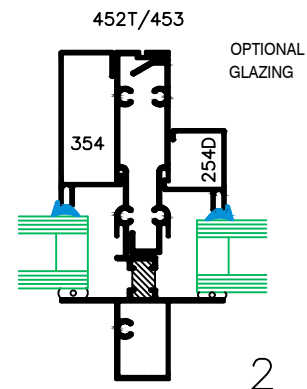

OPTIONAL
GLAZING

2

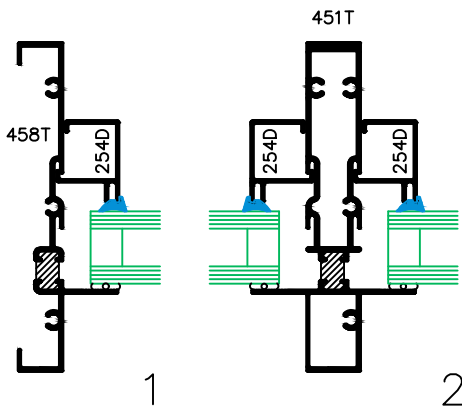

1

2

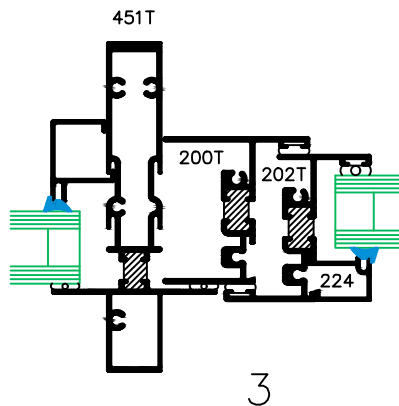

3

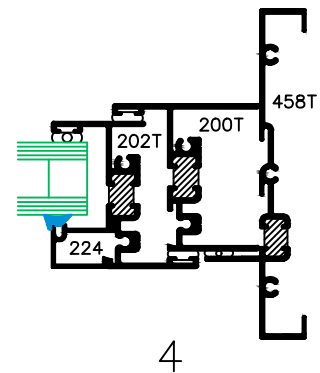

4

WIND LOAD CHART FOR 450T SERIES - PART # 451T

SPAN CHART

**SPAN CHART IS FOR ESTIMATION ONLY.
DO NOT UTILIZE FOR DETAILED DESIGN.
CHART IS BASED ON DEFLECTION ANALYSIS
ONLY**

Mullion Centres (Tributary width) In Meters

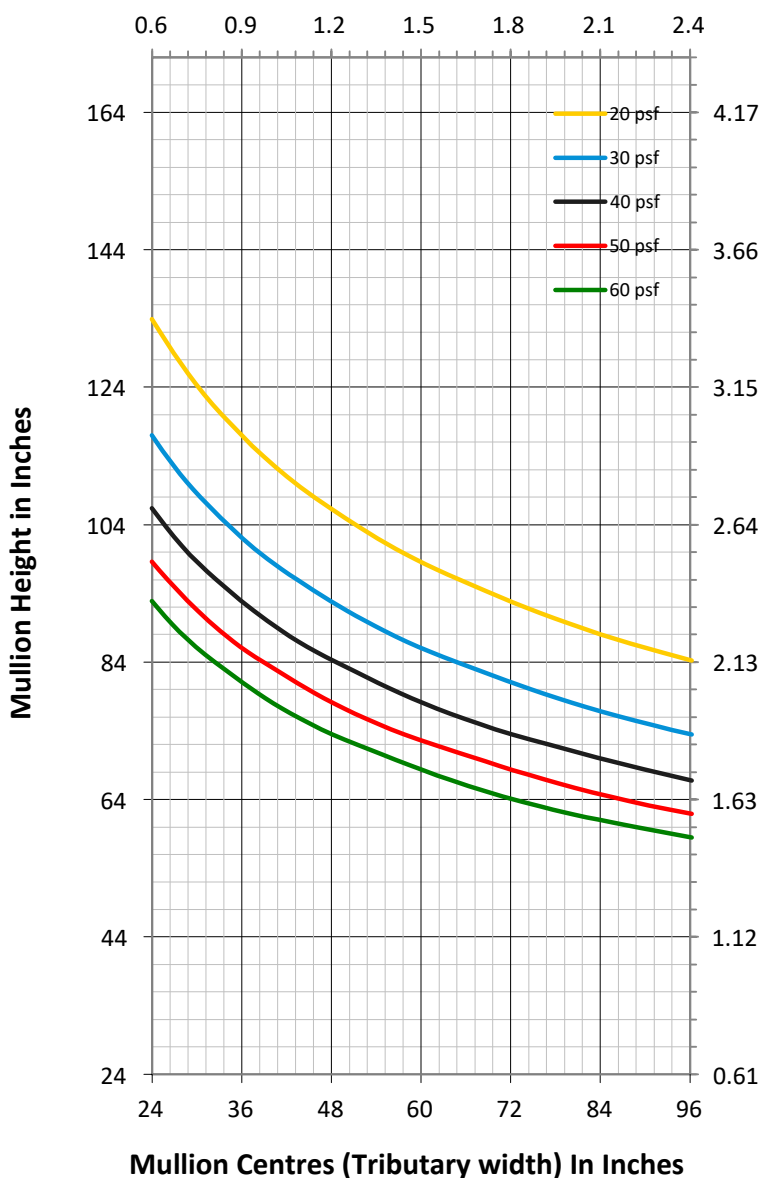

MULLION SECTION

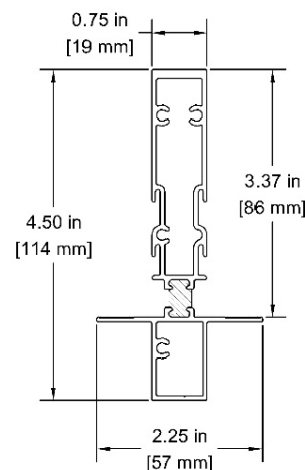

SYSTEM PROPERTIES

Moment of Inertia, Section Modulus & Area

Moment of Inertia, I _{xx}	I _{xx} = 1.82 in ⁴
Section Modulus, S _{xx}	S _{xx} = 0.37 in ³
Total Area	A = 0.95 in ²

Modulus of Elasticity

Aluminum	10,000,000 PSI
Steel	29,000,000 PSI

GENERAL NOTES

1. Deflection Limit: L/175 up to 13.5ft, L/240 + 0.25" over 13.5ft
2. Assume horizontal members provide lateral support
3. Steel moment of inertia converted to polyester, vinyl or aluminum equivalent
4. CANADIAN PROJECTS: Use SLS wind loads or modify the specified wind load by 0.75 before utilizing this chart. i.e. if project specifications require p_{net} = 40 psf, utilize 30 psf on this chart (0.75 x 40 = 30). (Based on NBCC 2020).

WIND LOAD CHART FOR 450T - PART # 452T/353

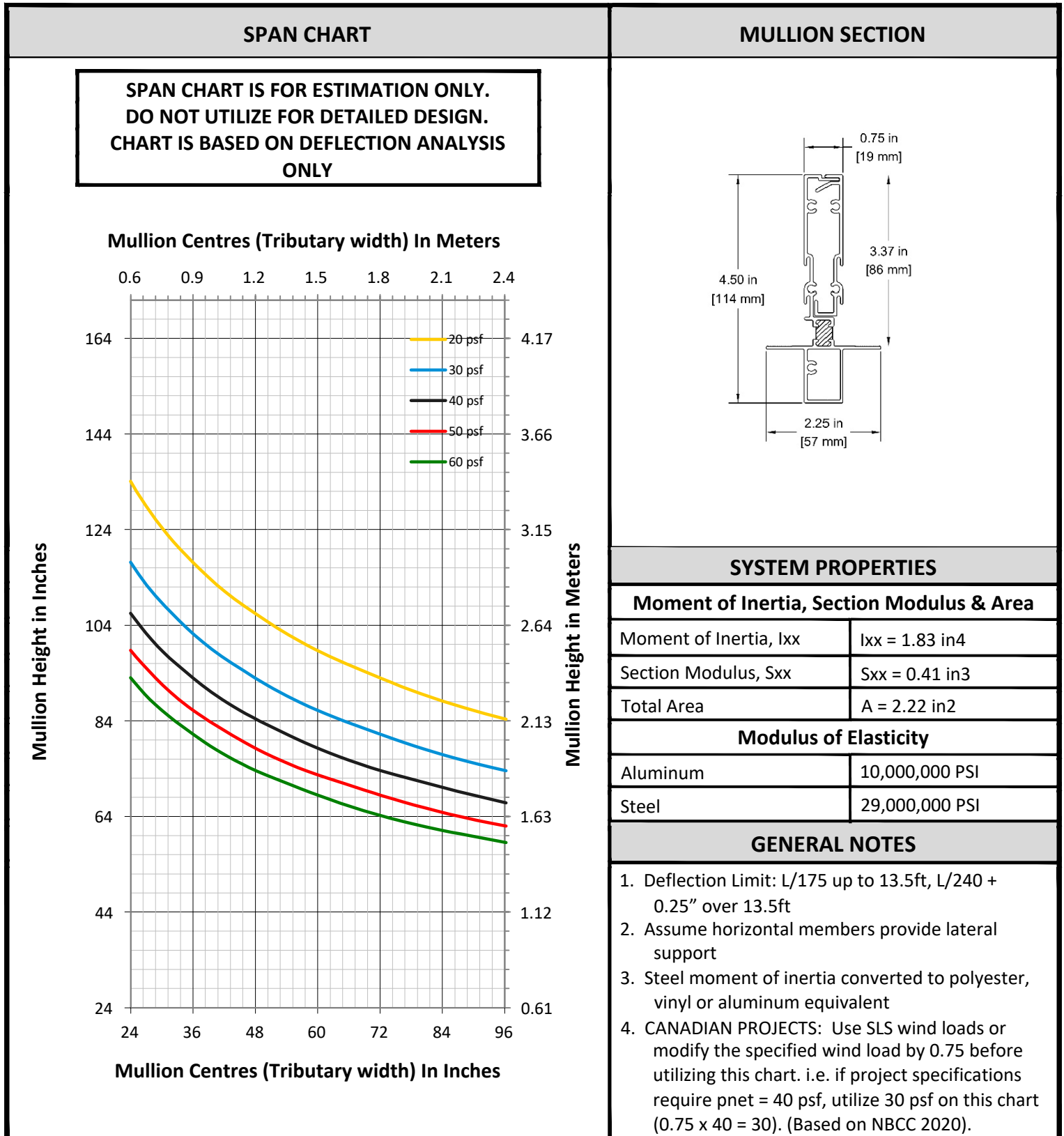

DEAD LOAD CHART FOR 450T SERIES - PART # 451T

SPAN CHART

SPAN CHART IS FOR ESTIMATION ONLY.
DO NOT UTILIZE FOR DETAILED DESIGN.
CHART IS BASED ON DEFLECTION ANALYSIS
ONLY

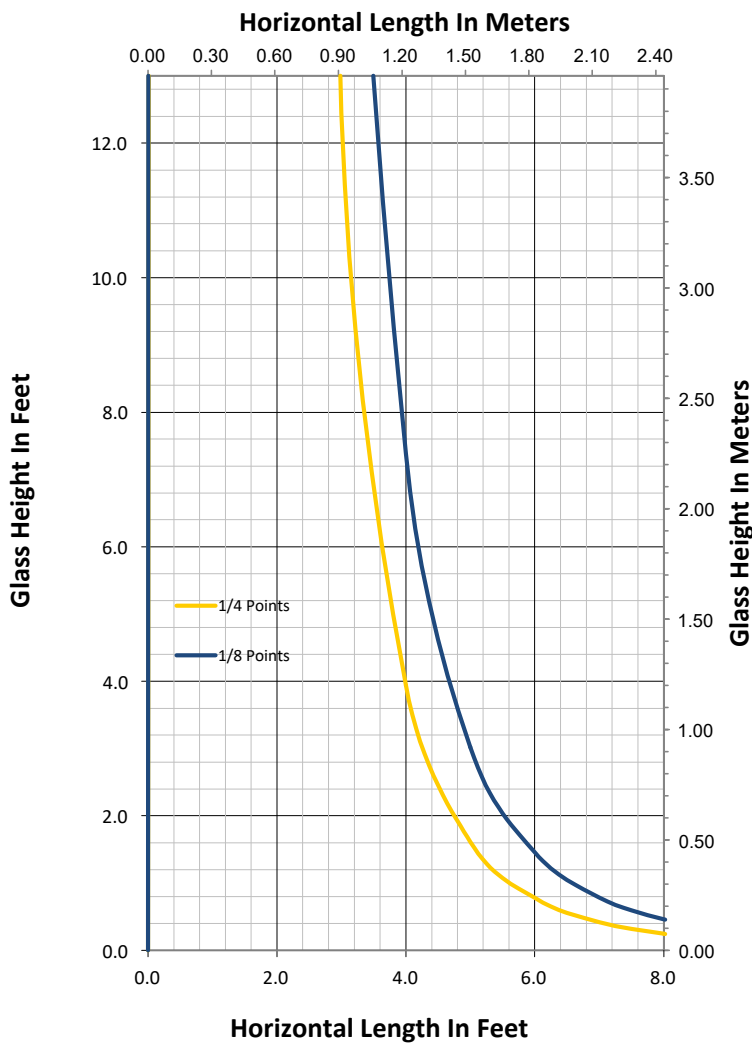

MULLION SECTION

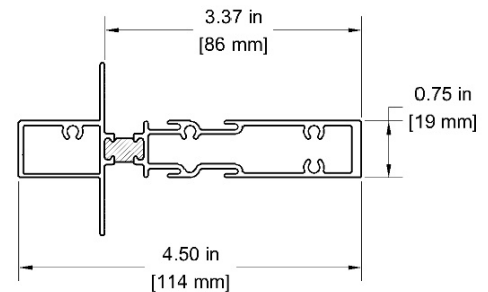

SYSTEM PROPERTIES

Moment of Inertia, Section Modulus & Area

Moment of Inertia, I_{yy}	$I_{yy} = 0.12 \text{ in}^4$
Section Modulus, S_{yy}	$S_{yy} = 0.13 \text{ in}^3$
Total Area	$A = 0.95 \text{ in}^2$

Modulus of Elasticity

Aluminum	10,000,000 PSI
Steel	29,000,000 PSI

GENERAL NOTES

1. Deflection Limit: 0.125" (3.2mm).
2. Charts are calculated assuming a 1" overall sealed unit (6mm/13mm spacer/6mm)
3. Calculations are based on the position of the setting blocks being placed at 1/4 or 1/8 points.



**METRO
ALUMINUM**

Products Ltd.

460T SERIES

T/B FIXED WINDOW SYSTEM WITH
TOPHAT EXTENSION 6 1/4" (158.8 mm)

E





**METRO
ALUMINUM**
Products Ltd.

460T SERIES

T/B FIXED WINDOW SYSTEM WITH
TOPHAT EXTENSION 6 1/4" (158.8 mm)

**E
20**

COMPONENTS

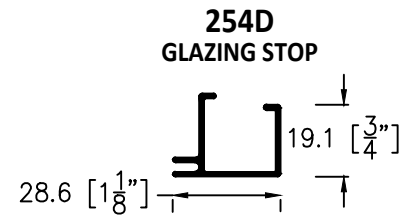
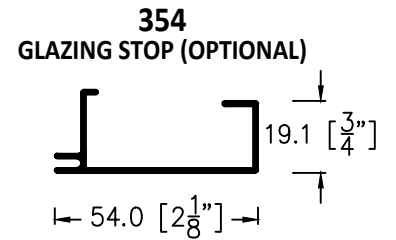
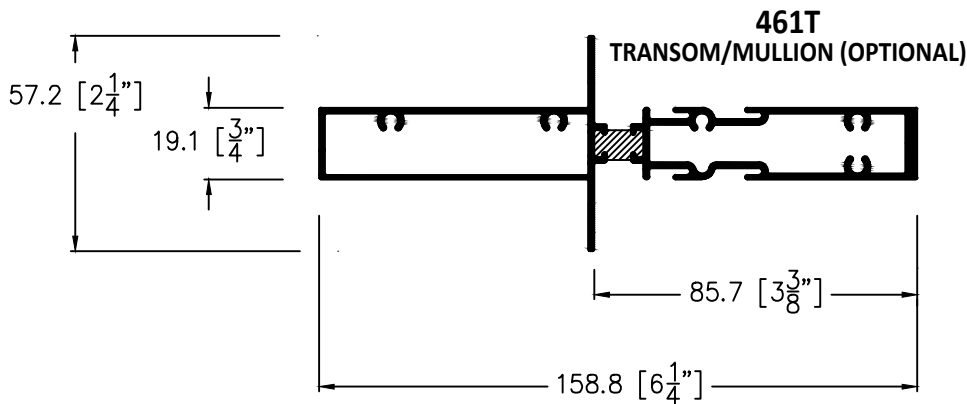
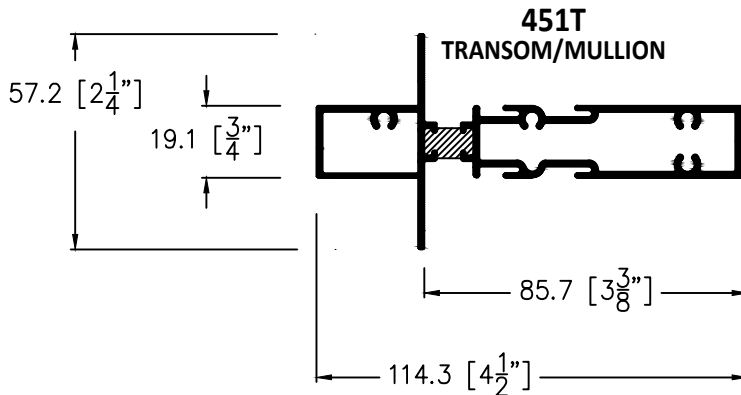
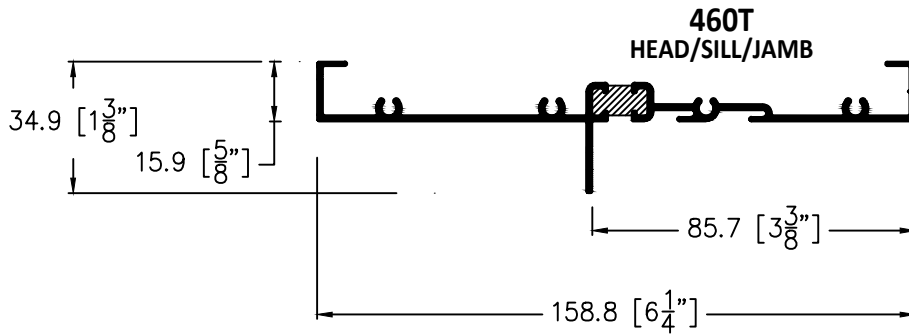

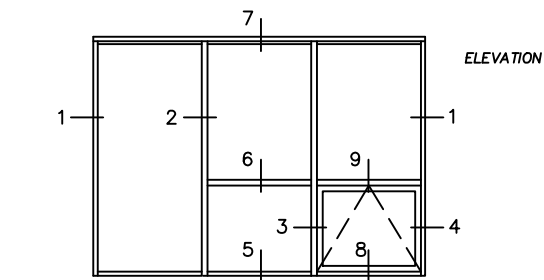

DETAILS

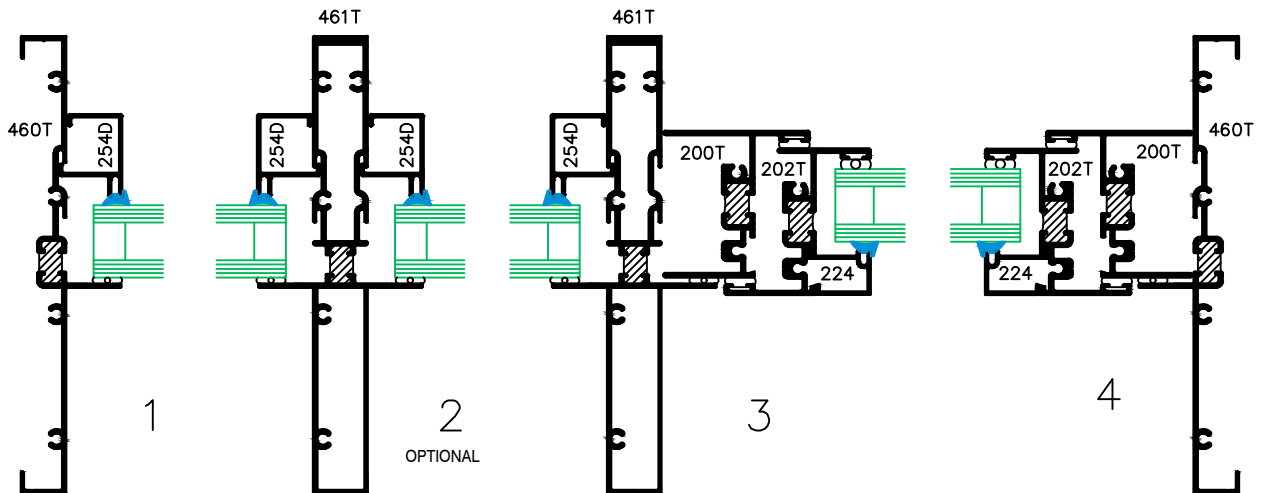
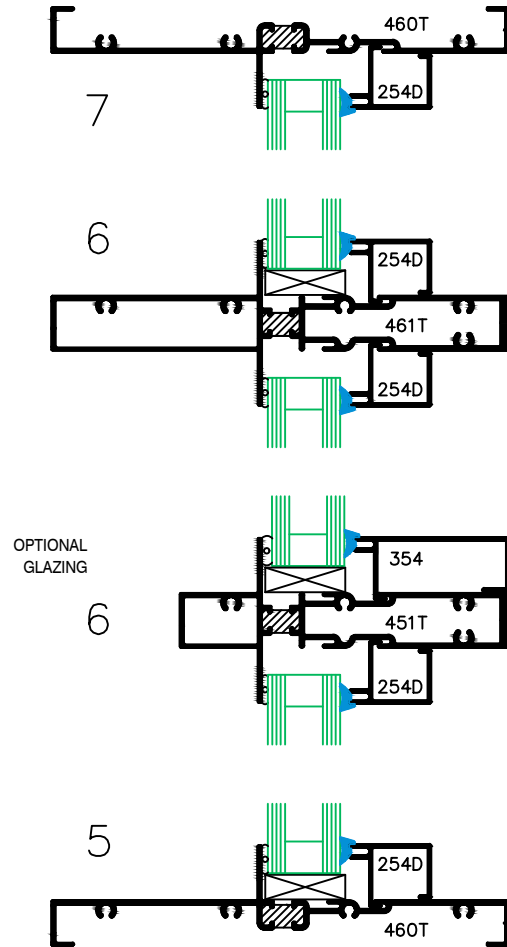
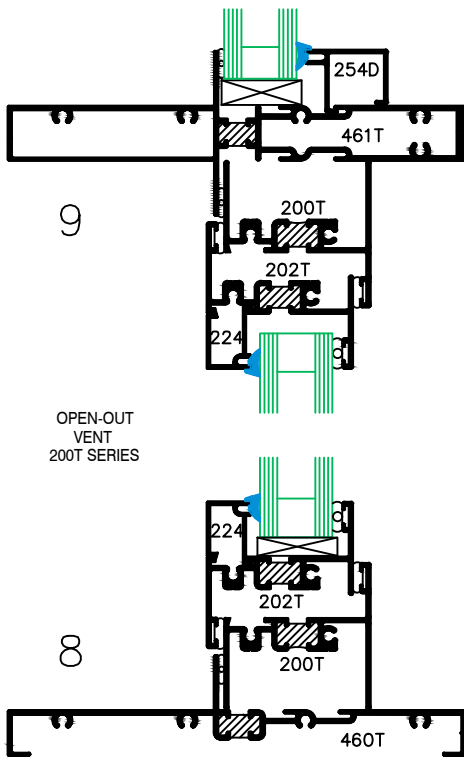

WIND LOAD CHART FOR 460T SERIES - PART # 451T

SPAN CHART

SPAN CHART IS FOR ESTIMATION ONLY.
DO NOT UTILIZE FOR DETAILED DESIGN.
CHART IS BASED ON DEFLECTION ANALYSIS ONLY

Mullion Centres (Tributary width) In Meters

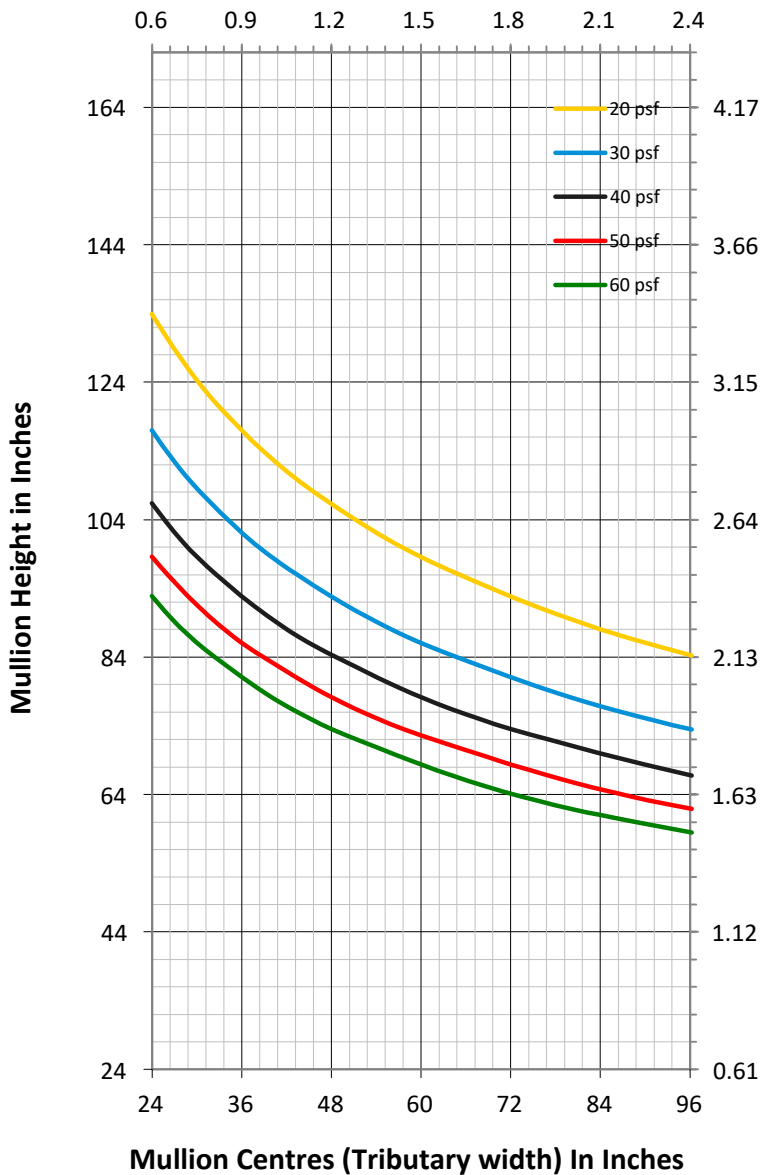

MULLION SECTION

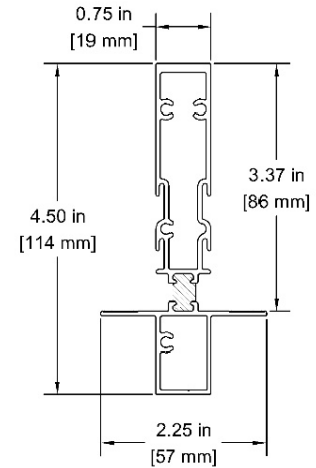

SYSTEM PROPERTIES

Moment of Inertia, Section Modulus & Area

Moment of Inertia, I _{xx}	I _{xx} = 1.82 in ⁴
Section Modulus, S _{xx}	S _{xx} = 0.37 in ³
Total Area	A = 0.95 in ²

Modulus of Elasticity

Aluminum	10,000,000 PSI
Steel	29,000,000 PSI

GENERAL NOTES

1. Deflection Limit: L/175 up to 13.5ft, L/240 + 0.25" over 13.5ft
2. Assume horizontal members provide lateral support
3. Steel moment of inertia converted to polyester, vinyl or aluminum equivalent
4. CANADIAN PROJECTS: Use SLS wind loads or modify the specified wind load by 0.75 before utilizing this chart. i.e. if project specifications require p_{net} = 40 psf, utilize 30 psf on this chart (0.75 x 40 = 30). (Based on NBCC 2020).

DEAD LOAD CHART FOR 460T SERIES - PART # 451T

SPAN CHART

**SPAN CHART IS FOR ESTIMATION ONLY.
DO NOT UTILIZE FOR DETAILED DESIGN.
CHART IS BASED ON DEFLECTION ANALYSIS
ONLY**

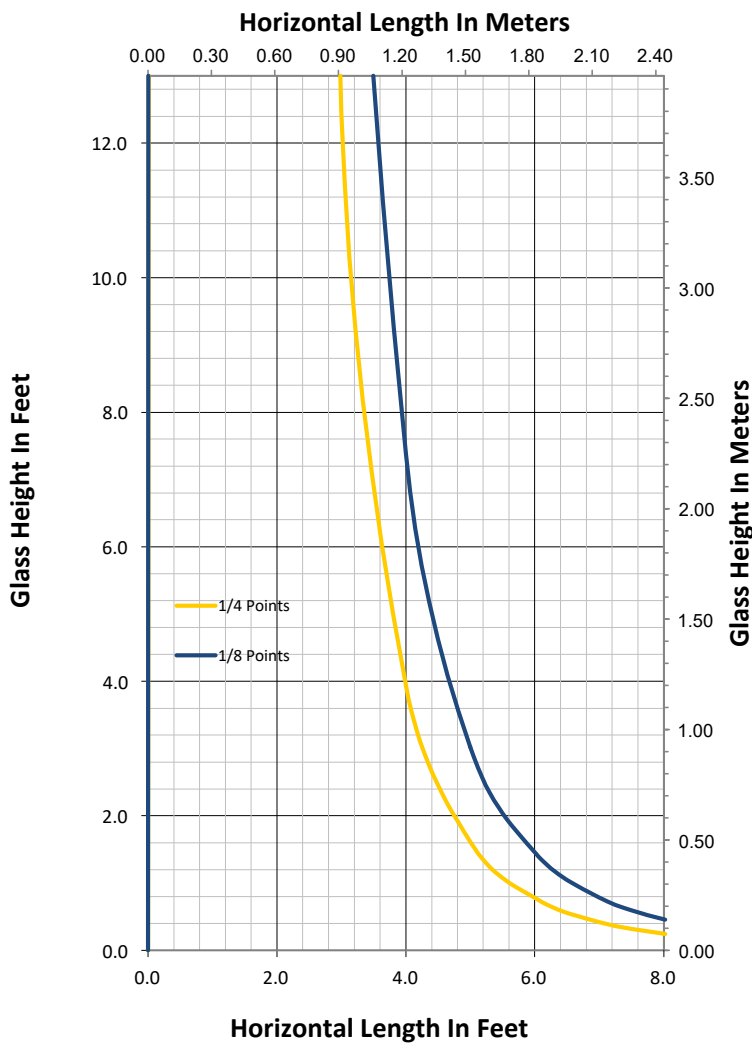

MULLION SECTION

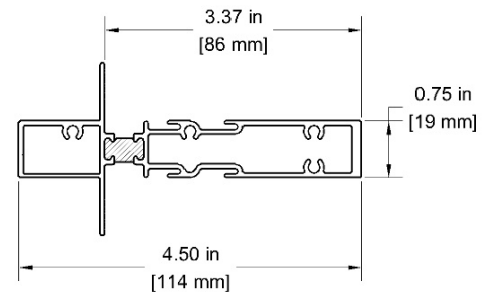

SYSTEM PROPERTIES

Moment of Inertia, Section Modulus & Area

Moment of Inertia, I_{yy}	$I_{yy} = 0.12 \text{ in}^4$
Section Modulus, S_{yy}	$S_{yy} = 0.13 \text{ in}^3$
Total Area	$A = 0.95 \text{ in}^2$

Modulus of Elasticity

Aluminum	10,000,000 PSI
Steel	29,000,000 PSI

GENERAL NOTES

1. Deflection Limit: 0.125" (3.2mm).
2. Charts are calculated assuming a 1" overall sealed unit (6mm/13mm spacer/6mm)
3. Calculations are based on the position of the setting blocks being placed at 1/4 or 1/8 points.

- 
- 01 - General Specifications
 - 02 - 200 Series
 - 03 - 200 Series - Details
 - 05 - 200T Series
 - 06 - 200T Series - Details
 - 10 - Vent Hardware

Part 1 - GENERAL

Scope - The vent window system shall be _____ series as manufactured by METRO ALUMINUM Products Ltd. Supply and install aluminum framing, as described on the architectural drawings and as specified herein.

Work Not Included - See: Specifier's lists of excluded items; Items furnished but not installed and/or Items installed but not furnished.

Related Work Specified Elsewhere - See: Specifier's lists and related Sections.

Design & Performance Requirements - Window fixed and operable assemblies shall fully comply with the applicable standard specifications as described in Section 10 - Test requirements of CAN/CSA-A440-M90 - Windows. (Specifier's selection).

Submittals - Shop Drawings & Samples - Submit all documentation and samples for review by Consultant at one time, prior to fabrication of curtain wall products.

Quality Assurance - Provide all necessary information to show that all involved products meet or exceed the requirements of these specifications.

Delivery, Storage and Handling - Deliver, store, handle, protect and schedule materials and products so as to avoid any damage. Follow recommendations of AAMA CW-10 "Care and Handling of Architectural Aluminum from Shop to Site" and others as applicable.

Part 2 - PRODUCTS

Materials - All materials to meet the applicable minimum design and specifications requirements. Any defects impairing strength, durability or appearance are not acceptable. Extruded aluminum shall be AA 6063 T6 alloy and temper - $F_y = 110$ MPa (16 KSI) minimum. Sufficient strength and size assembly and anchoring shall be made of corrosion-resistant and compatible material such as cadmium or zinc plated carbon steel or stainless steel. Separate incompatible materials and prevent galvanic action (electrolytic corrosion). Structurally adequate anchoring metal brackets shall be anticorrosive painted. Conventional wet-dry/dry-wet/dry-dry, inside/outside glazing method shall be applicable (Specifier's selection). Gasketing to utilize: standard glazing butyl tape completed with hard extruded shim and interior dense gasket extruded from Neoprene, EPDM or other equal material, as required. Gasket profile shall be designed and sized to uniformly fit tight and properly seal glass-metal interfacing. Acceptable gasket compression range to be 0.7 to 1.7 kN/m (4 - 10 lbs/in). Glass setting to be compatible with glass unit seals and/or other parts involved as required.

System Description - Framing System shall be 200, 200T - non-thermally broken/uninsulated (thermally broken/insulated - T), for single glass (sealed insulating glass units) METRO Series - Specifier selection - as manufactured by METRO ALUMINUM Products Ltd. and compatible with 250, 350 and 450 Series window systems, and 2400/2500 curtain wall systems.

Where applicable, thermal break shall be polyurethane poured-in resin type.

Glass perimeter retention, for specified glazing methods, shall be achieved by glazing shimmed tape/inorganic rubber gasket and glazing stop profile c/w inorganic rubber gasket. Glass hard bite to be 12.7 mm (0.5") minimum. Whenever substitute/alternative products are considered, supporting data to be submitted ten (10) days prior to bid date to allow for valid comparison. Approval of alternates to be confirmed in advance of bid closing by addendum only.

Hardware - Operable vents should be manufactured as Top-Hung-Open-Out (THOO), Side-Hung-Open-Out (SHOO), Top-Hung-Open-in (THOI), Side-Hung-Open-In (SHOI) - Specifier's selection. Friction arms, aluminum hinges, cam handles, understay arms, or others as required and/or applicable - Specifier's selection.

Fabrication - Extruded profiles for fixed frame and operable vent shall be accurately fabricated and assembled and sealed to provide air/water tight fit hairline joints only. Fastening shall allow for permanent true and square set of frame elements. Assembly shall utilize concealed screws only. Properly sealed frame assembly interfacing mitre and butt joints shall result in uninterrupted continuity of air barrier and compartmentization. Frame assemblies shall be free of warp. No exposed fasteners are permitted. Selected operable vent hardware to be compatible with window framing. Sill and head flashing shall be designed and fabricated to suit site conditions as required.

Finish - All exposed surfaces shall be finished as specified. The finish, as per AAM designation, shall be (Specifier's selection):

Standard clear anodizing to AA - M12C22A31

Standard perma bronze to AA - M12C22A44

Standard black anodizing to AA - M10C21A44

Duracron acrylic enamel to AA - M12C4XR1X

Custom paint qualities and colors - Specifier's selection.

Part 3 - EXECUTION

Installation - Anchoring shall suit perimeter conditions of rough openings and seals as required. Prefabricated/preglazed framing to be installed at prepared openings, at correct locations as shown on drawings, set level, plumb, square and aligned with other work in accordance with manufacturer's instructions, approved shop and erection drawings. Perimeter joints to be sealed/caulked as specified and detailed to ensure weathertight assembly.

Protection and Cleaning - Work to be protected from damage during and after installation. Consult with manufacturer and installer to determine appropriate protective measures. The General Contractor shall be responsible for protection during construction and for final cleaning. After installation, aluminum work and glass to be cleaned according to instructions/manuals provided by product manufacturers and glaziers. Use appropriate cleaning materials and methods. Do not scratch or damage glass or finishes.



COMPONENTS

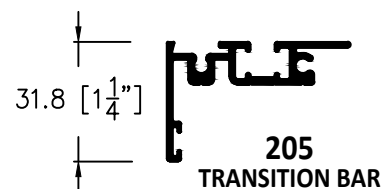
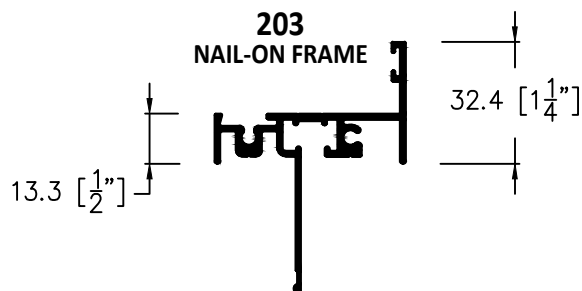
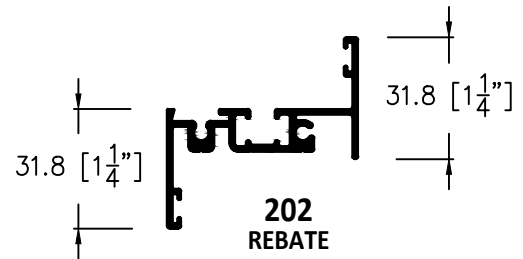
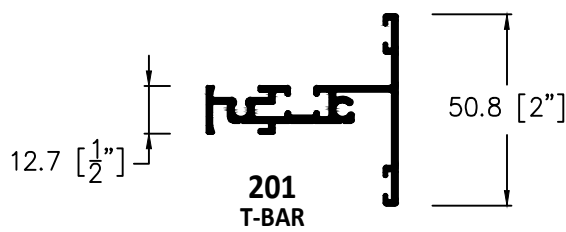
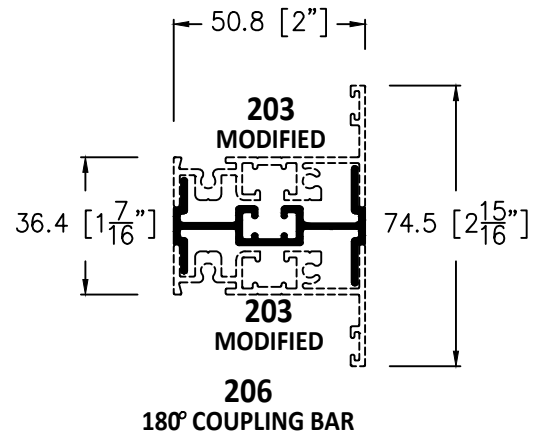
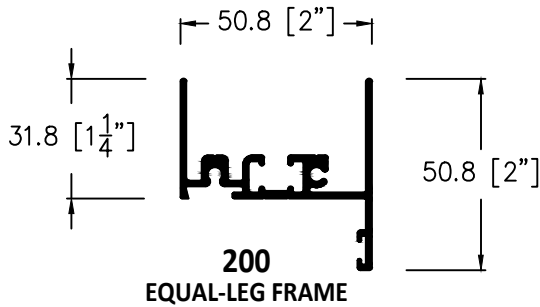
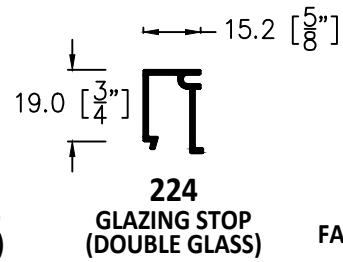
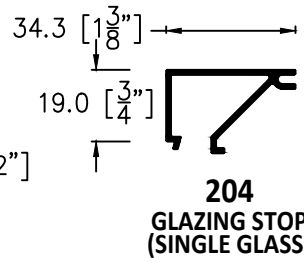
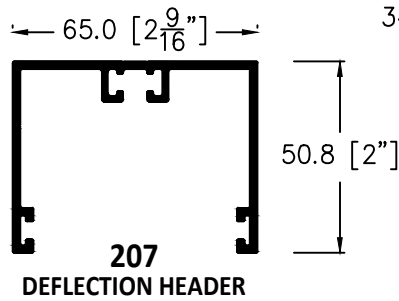

DETAILS

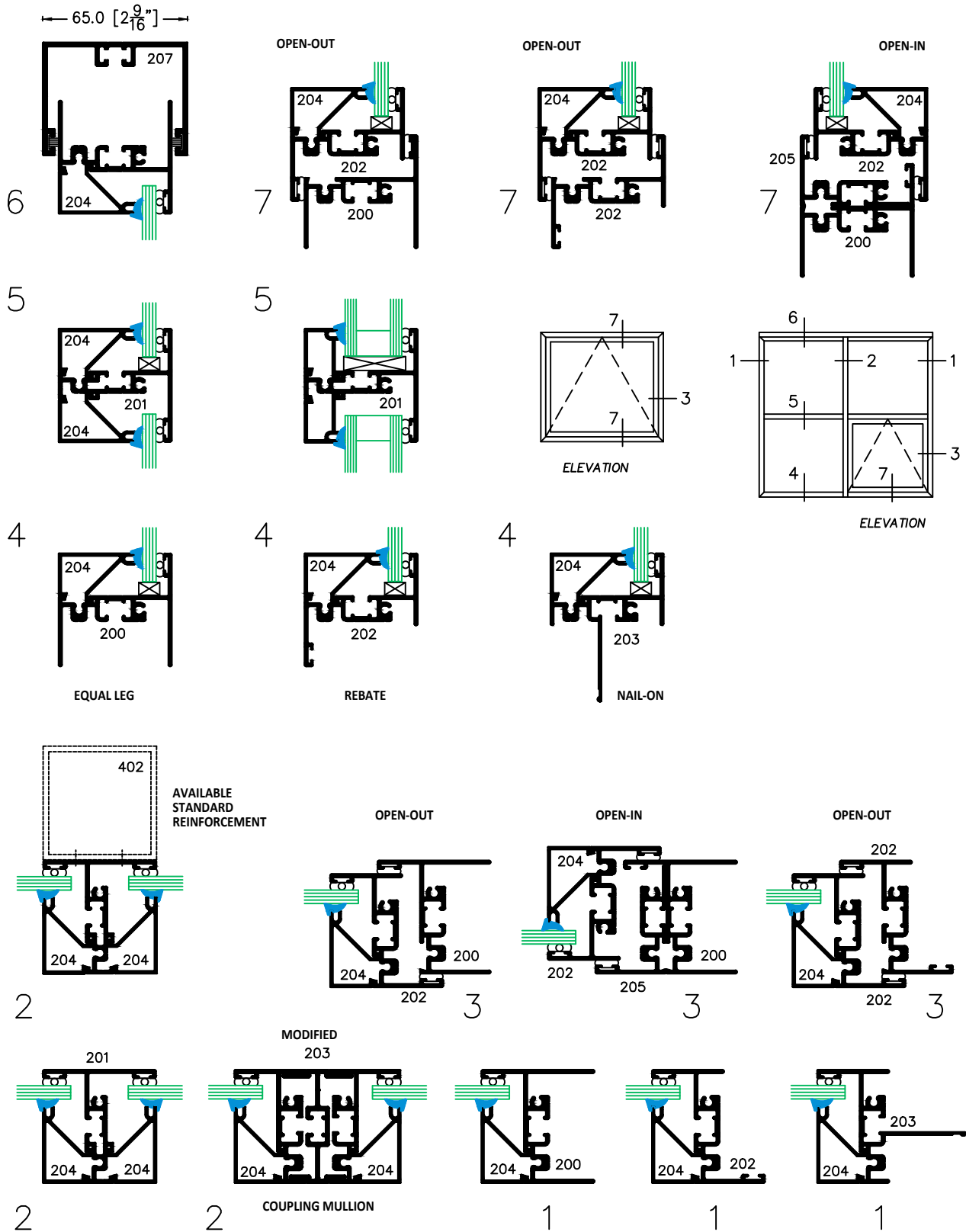



**METRO
ALUMINUM**

Products Ltd.

200T SERIES

THERMALLY BROKEN
VENT WINDOW SYSTEM 2" (50.8 mm)

F





**METRO
ALUMINUM**

Products Ltd.

200T SERIES

THERMALLY BROKEN
VENT WINDOW SYSTEM 2" (50.8 mm)

**F
05**

COMPONENTS

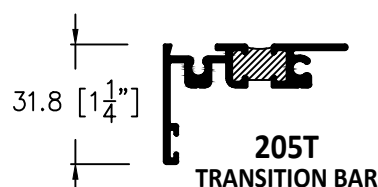
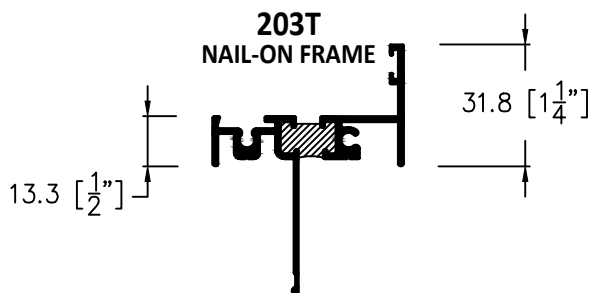
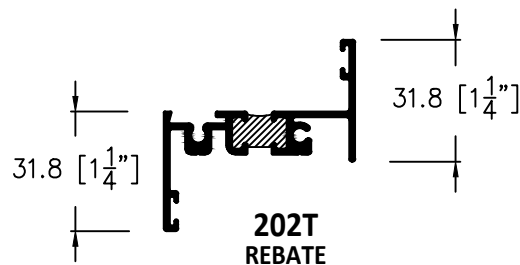
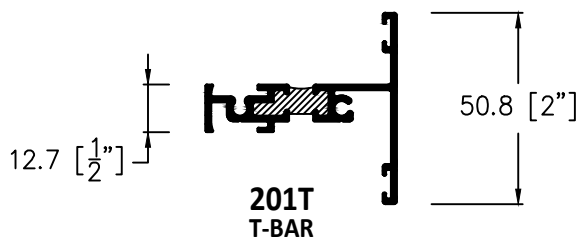
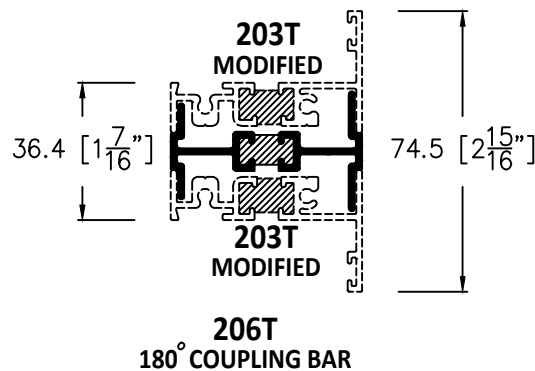
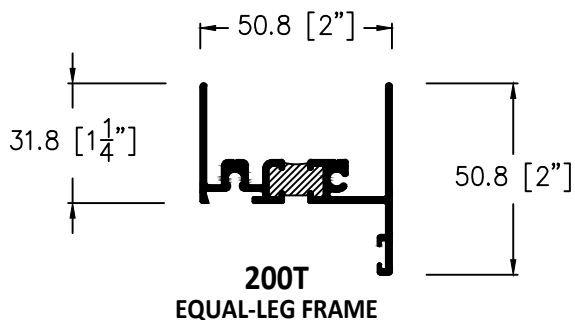
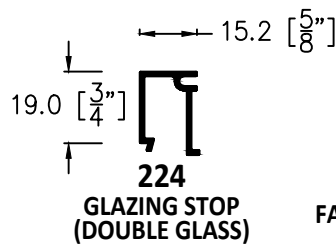
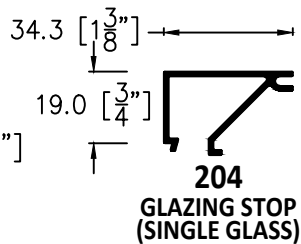
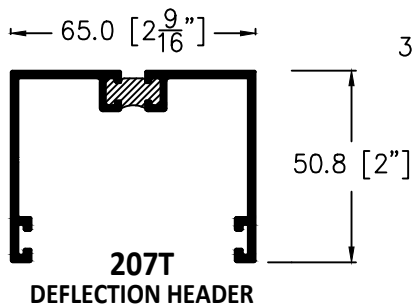



**METRO
ALUMINUM**

Products Ltd.

200T SERIES

THERMALLY BROKEN
VENT WINDOW SYSTEM 2" (50.8 mm)

**F
06**

DETAILS

65.0 [2 $\frac{9}{16}$ "]

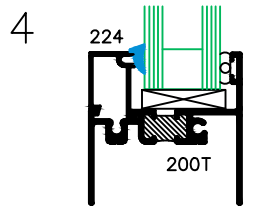
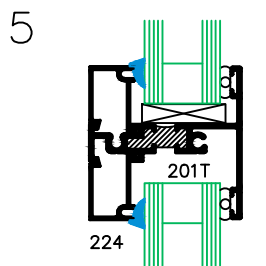
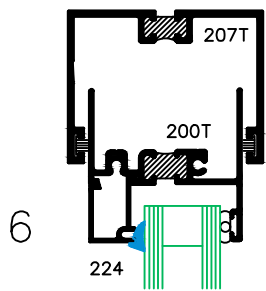

EQUAL LEG

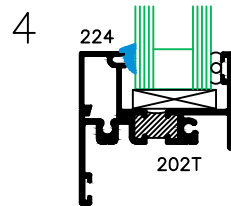
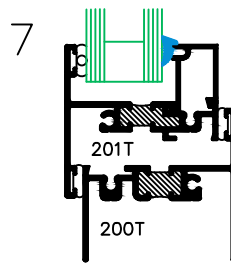
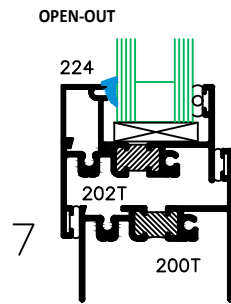

REBATE

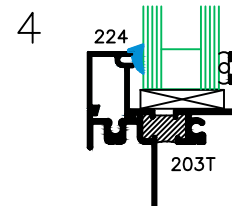
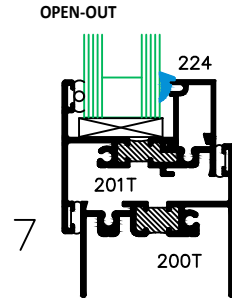

NAIL-ON

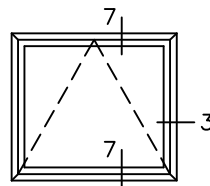
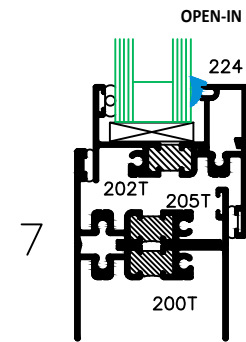

ELEVATION

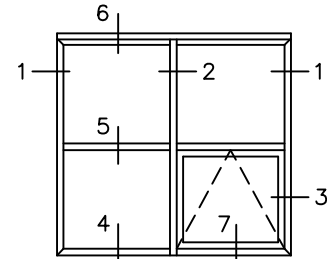

ELEVATION

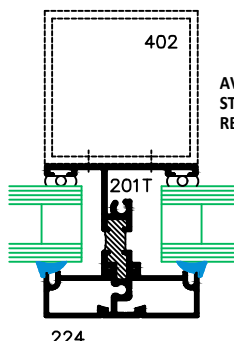
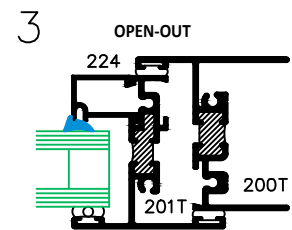

2

AVAILABLE
STANDARD
REINFORCEMENT

OPEN-OUT

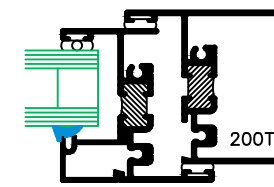

3

OPEN-IN

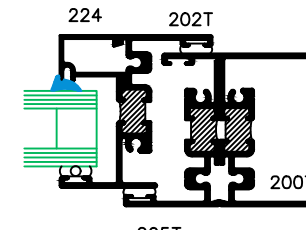

3

OPEN-OUT

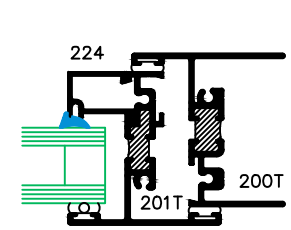

3

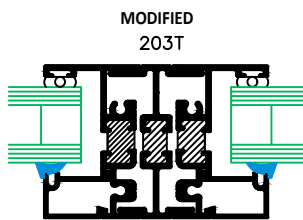

2

COUPLING MULLION

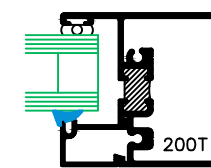

1

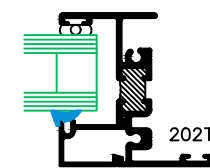

1

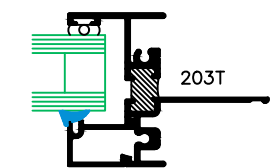

1



VFH-08/10/12/16/20/24
4 BAR FRICTION HINGE



VEH-10/12/16
EGRESS FRICTION HINGE

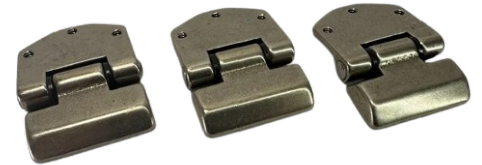

VBH-02
VENT BUTT HINGE



VBH-02 BP
VENT BUTT HINGE BLACK



VT-100/101/104
STANDARD CAM HANDLES AND STRIKE



VT-102/103/104
RING CAM HANDLE AND STRIKE



VT-200/201
INSWING CAM HANDLE



VT-202/203/204
INSWING RING CAM HANDLE AND STRIKE



VT-220
POLE EYE



VT-206/221
INSWING TRANSOM CATCH & POLE HOOK



VT-341
SASH FRICTION ADJUSTER



VT-351
UNDER SCREEN PUSH BAR



VT-300
DUAL ARM ROTO OPERATOR



VT-301
PIVOT ROTO TRACK PAIR

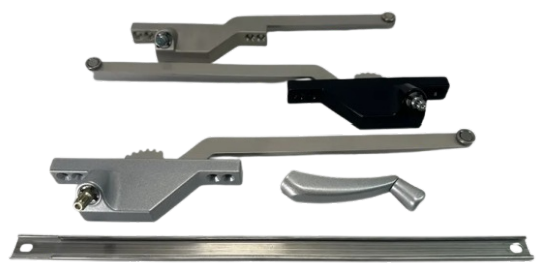

VT-310/311
SINGLE ARM ROTO OPERATOR



VT-312
SINGLE ARM ROTO ARM TRACK



VT-302
ROTO CRANK HANDLE



VT-302F
FOLDING ROTO CRANK HANDLE



VT-302T
ROTO T-CRANK HANDLE



VT-320/321
CASEMENT LOCK HANDLE & STRIKE



SCL/CLR
SMALL SCREEN CLIP



SCLSO/CLR
STANDOFF SCREEN CLIP



SOCOR
STANDOFF SCREEN CORNER

- 
- 01 - General Specifications
 - 02 - 3000/3000T Series - T-bar System
 - 03 - 3000/3000T Series - Details
 - 04 - 3000/3000T Series - Snow Load Charts
 - 07 - 3400 Series - Rafter Purlin System
 - 08 - 3400 Series - Details
 - 08 - 3400 Series - Snow Load Charts
 - 14 - 3400T Series - Thermally Broken Rafter Purlin System
 - 15 - 3400T Series - Details
 - 16 - 3400T Series - Snow Load Charts

Part 1 - GENERAL

Scope - The skylight framing system shall be _____ Series as manufactured by METRO ALUMINUM Products Ltd. Supply and install aluminum framing, as described on the architectural drawings and as specified herein.

Work Not Included - See: Specifier's lists of excluded items; Items furnished but not installed and/or Items installed but not furnished.

Related Work Specified Elsewhere - See: Specifier's lists and related Sections.

Design & Performance Requirements - Framing to fully comply with the applicable standard specifications as typically referenced to the following performance requirements criteria: Air Tightness, Water Tightness, Wind and Snow (and other applicable) Load Resistance, Temperature Index and Energy Performance. (Specifier's selection)

Submittals - Shop Drawings & Samples - Submit all documentation and samples for review by Consultant at one time, prior to fabrication of curtain wall products.

Quality Assurance - Provide all necessary information to show that all involved products meet or exceed the requirements of these specifications.

Delivery, Storage and Handling - Deliver, store, handle, protect and schedule materials and products so as to avoid any damage. Follow recommendations of AAMA CW-10 "Care and Handling of Architectural Aluminum from Shop to Site" and others as applicable.

Part 2 - PRODUCTS

Materials - All materials to meet the applicable minimum design and specifications requirements. Any defects impairing strength, durability or appearance are not acceptable. Extruded aluminum shall be AA 6063 T6 alloy and temper - $F_y = 110$ MPa (16 KSI) minimum. Sufficient strength and size assembly fasteners and anchoring bolts shall be made of corrosion-resistant and compatible material such as cadmium or zinc plated carbon steel or stainless steel. Separate incompatible materials and prevent galvanic action (electrolytic corrosion). Structurally adequate anchoring metal brackets shall be anticorrosive painted. Glass-to-metal contact is not acceptable.

3000/3000T Series - Glazing shall utilize standard interior extruded PVC gaskets and exterior rolled aluminum glazing beads as required for conventional dry-dry, outside glazing method with 2-side supported glass.

3400/3400T Series - Glazing shall utilize standard gaskets, dense interior and sponge exterior, shall be extruded from Neoprene, EPDM, or other equal material as required for conventional dry-dry, outside glazing method with 4-side supported glass. Gasket profiles shall be designed and sized to uniformly fit tight and properly seal glass-metal interfacing. Acceptable gasket compression range to be 0.7 to 1.7 kN/m (4 - 10 lbs/in).

Glass setting to be compatible with glass unit seals and/or other parts involved as required.

System Description - Framing Systems (Specifier's selection)

Reference face width dimension of extruded profiles shall be 2" (50.8 mm).

3000/3000T METRO Series - as manufactured by METRO ALUMINUM Products Ltd. - Conventional T-bar uninsulated (thermally broken/insulated) with internal drainage system and continuous anchor sill shoe for single glass and sealed insulating glass units, allowing for full integration with the rainscreen part of building envelope. Glass retention, as for dry-dry glazing method, shall be achieved by exterior glazing bead (retainer) profile. Glass hard bite to be 9.5 mm (0.375") minimum.

3400/3400T METRO Series - as manufactured by METRO ALUMINUM Products Ltd. - Thermally broken/insulated, tubular with internal drainage system for sealed insulating glass units or single glass, utilizing Rainscreen Principle and allowing for full integration with the building envelope. Purlins to be equipped with condensation gutters as required. Glass retention, as for dry-dry glazing method, shall be achieved by 4-side pressure plate (retainer) profile and inorganic rubber gasket. Glass hard bite to be 12.7 mm (0.5") minimum.

Whenever substitute/alternative products are considered, supporting data to be submitted ten (10) days prior to bid date to allow for valid comparison. Approval of alternates to be confirmed in advance of bid closing by addendum only.

Fabrication - Extruded profiles shall be accurately fabricated and assembled and sealed to provide air/water tight fit hairline joints only. Fastening shall allow for permanent true and square set of frame elements. Assembly shall utilize concealed screws only. Properly sealed frame assembly joints to result in continuity of air barrier on the system's inside side. Frame assemblies shall be free of warp. Uniformly compressed glazing gaskets shall secure glass in place. No exposed fasteners are permitted.

Finish - All exposed surfaces shall be finished as specified. The finish, as per AAM designation, shall be (Specifier's selection):

Standard clear anodizing to AA - M12C22A31

Standard perma bronze to AA - M12C22A44

Standard black anodizing to AA - M10C21A44

Duracron acrylic enamel to AA - M12C4XR1X

Custom paint qualities and colors - Specifier's selection.

Part 3 - EXECUTION

Installation - Steel embeds and anchoring brackets to be placed and ready as required. Anchoring shall suit perimeter conditions of rough openings and seals as required. Prefabricated framing to be installed at prepared structure, at correct locations as shown on drawings, set with required reference to level, plumb, square and aligned with other work in accordance with manufacturer's instructions, approved shop and erection drawings. Perimeter joints to be sealed/caulked as specified and detailed to ensure weathertight assembly.

Protection and Cleaning - Work to be protected from damage during and after installation. Consult with manufacturer and installer to determine appropriate protective measures. The General Contractor shall be responsible for protection during construction and for final cleaning. After installation, aluminum work and glass to be cleaned according to instructions/manuals provided by product manufacturers and glaziers. Use appropriate cleaning materials and methods. Do not scratch or damage glass or finishes.



3000/3000T SERIES

T-BAR SKYLIGHT SYSTEMS
2" (50.8 mm) BASE WIDTH

G

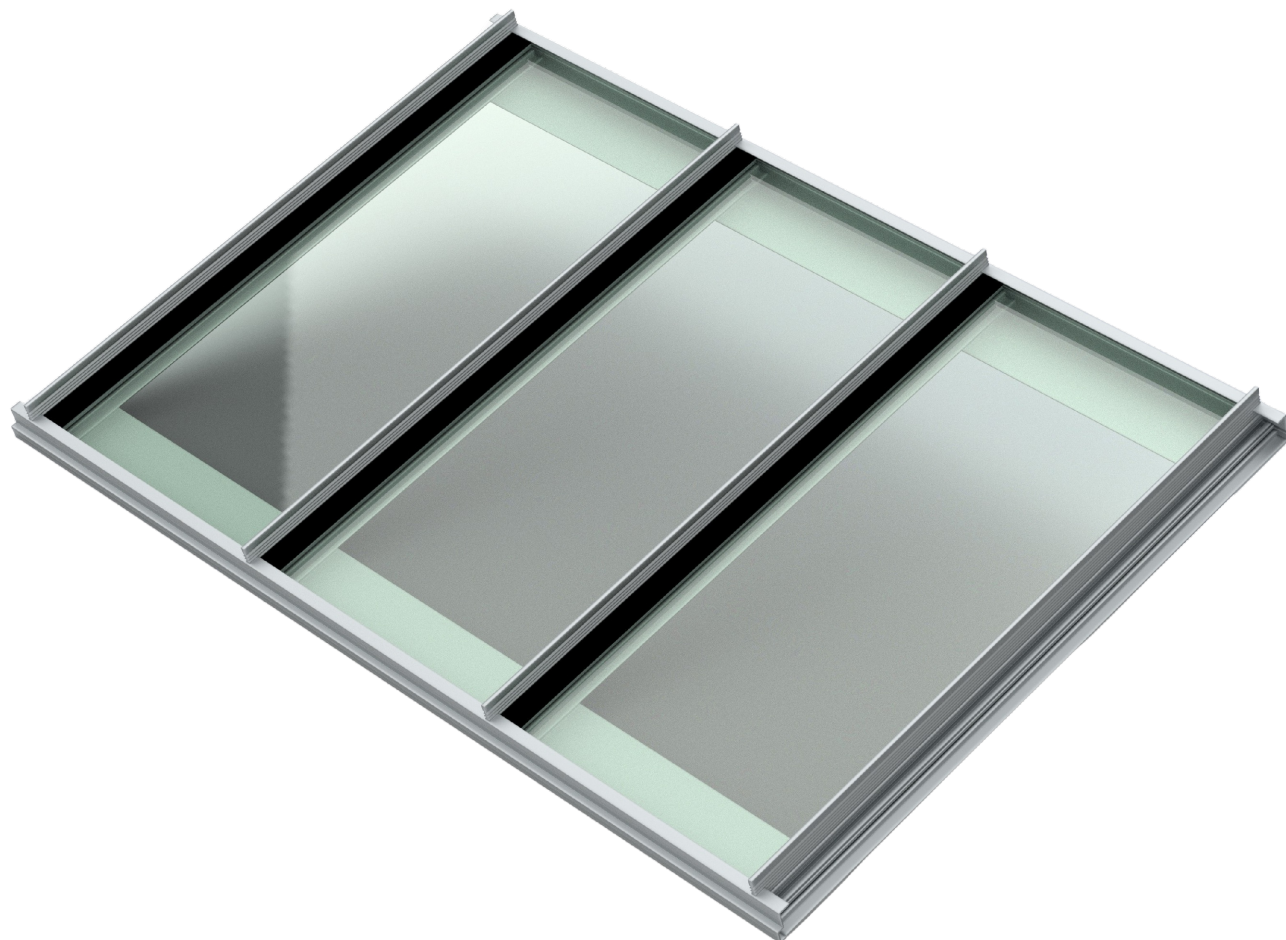



COMPONENTS

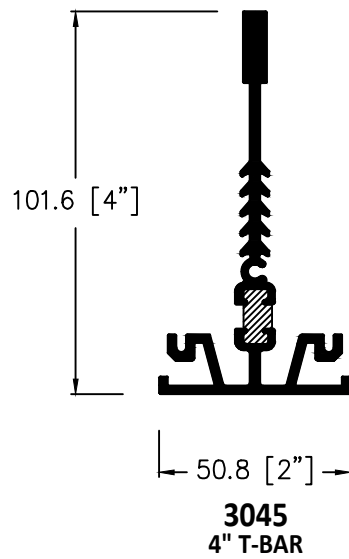
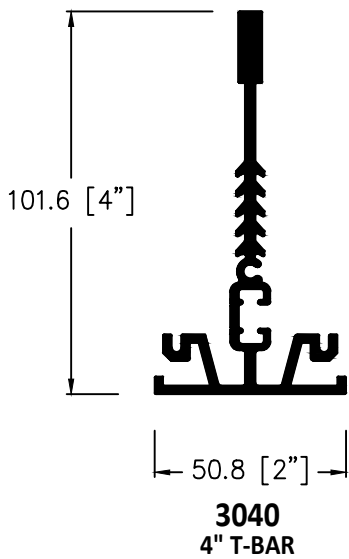
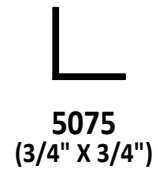
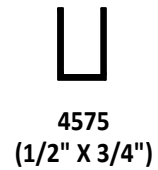
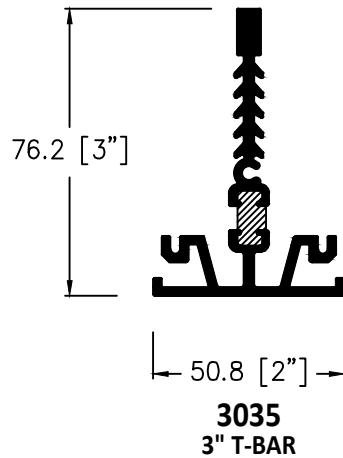
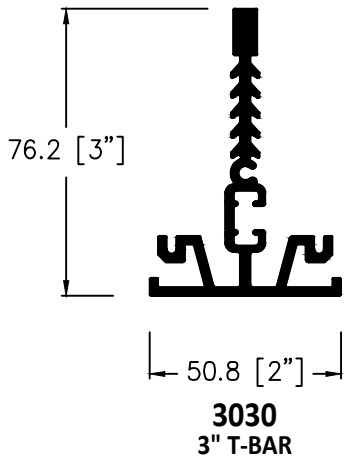
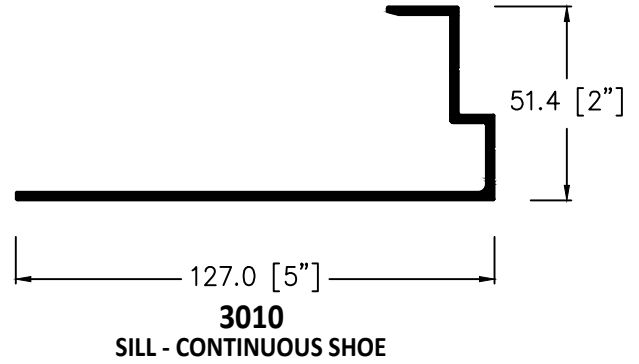
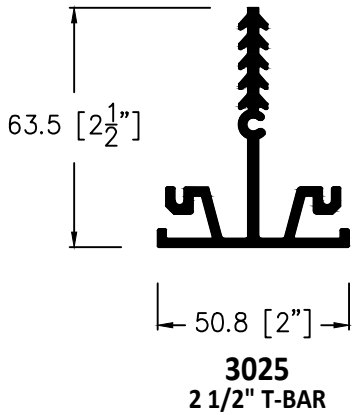



DETAILS

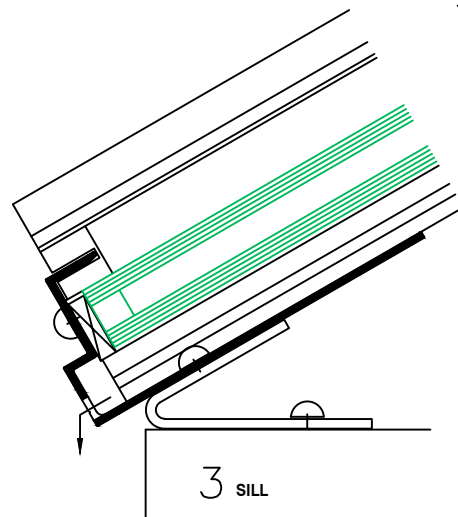
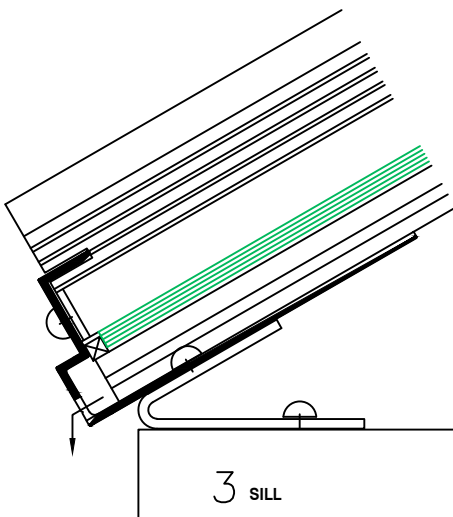
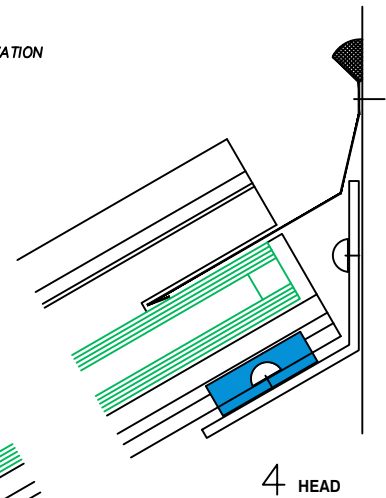
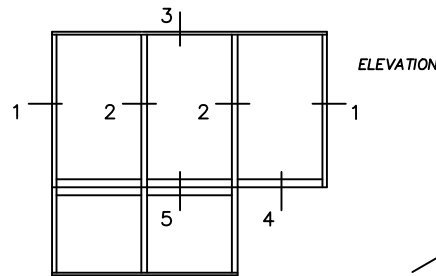
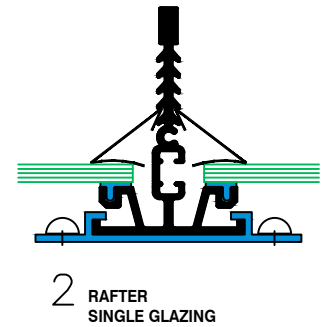
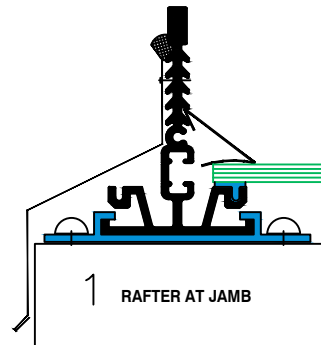
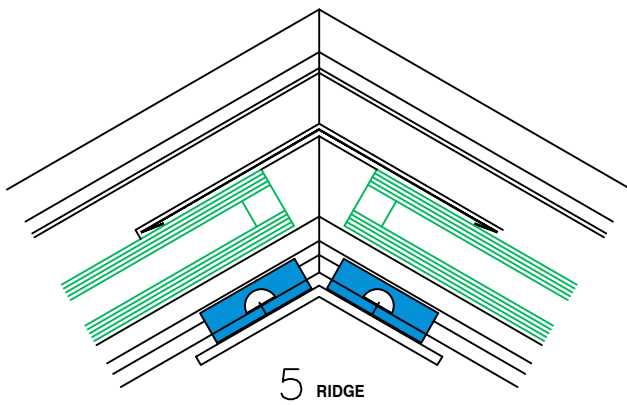
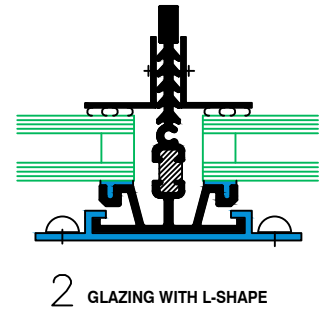
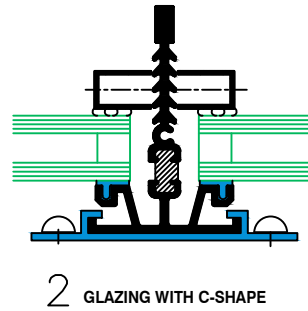
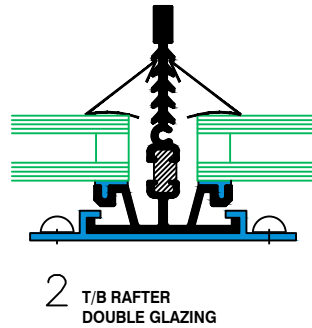
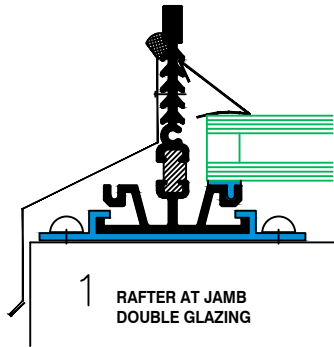

WIND LOAD CHART FOR 3000 SERIES - PART # 3025

SPAN CHART

**SPAN CHART IS FOR ESTIMATION ONLY.
DO NOT UTILIZE FOR DETAILED DESIGN.
CHART IS BASED ON DEFLECTION ANALYSIS
ONLY**

Mullion Centres (Tributary width) In Meters

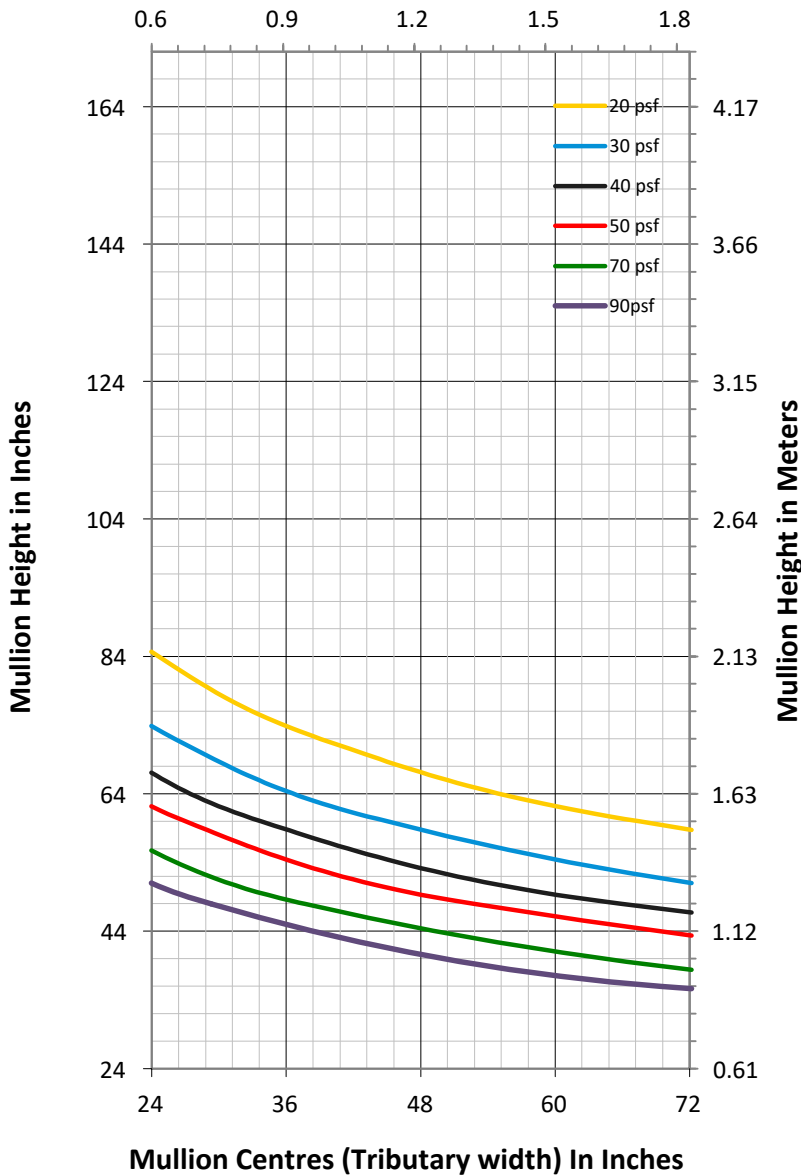

MULLION SECTION

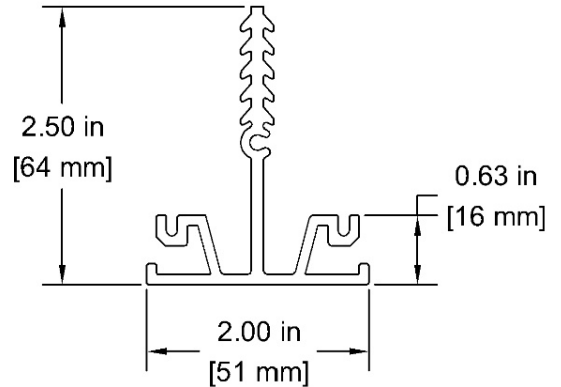

SYSTEM PROPERTIES

Moment of Inertia, Section Modulus & Area

Moment of Inertia, I_{xx}	$I_{xx} = 0.46 \text{ in}^4$
Section Modulus, S_{xx}	$S_{xx} = 0.27 \text{ in}^3$
Total Area	$A = 0.79 \text{ in}^2$

Modulus of Elasticity

Aluminum	10,000,000 PSI
Steel	29,000,000 PSI

GENERAL NOTES

1. Deflection Limit: $L/175$ up to 13.5ft, $L/240 + 0.25"$ over 13.5ft
2. Assume horizontal members provide lateral support
3. Steel moment of inertia converted to polyester, vinyl or aluminum equivalent
4. The design pressure (psf) shall be determined using the controlling load combination of dead, wind, live, and snow loads as applicable.

WIND LOAD CHART FOR 3000 SERIES - PART # 3030

SPAN CHART

SPAN CHART IS FOR ESTIMATION ONLY.
DO NOT UTILIZE FOR DETAILED DESIGN.
CHART IS BASED ON DEFLECTION ANALYSIS
ONLY

Mullion Centres (Tributary width) In Meters

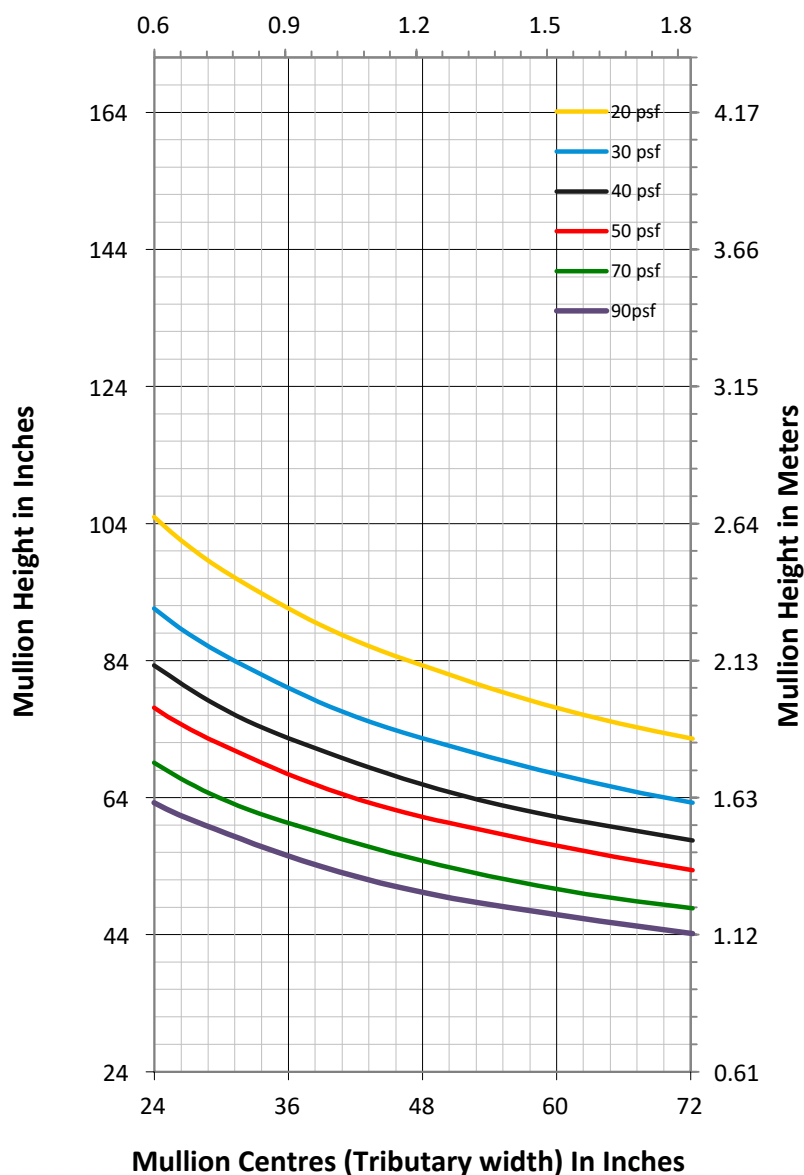

MULLION SECTION

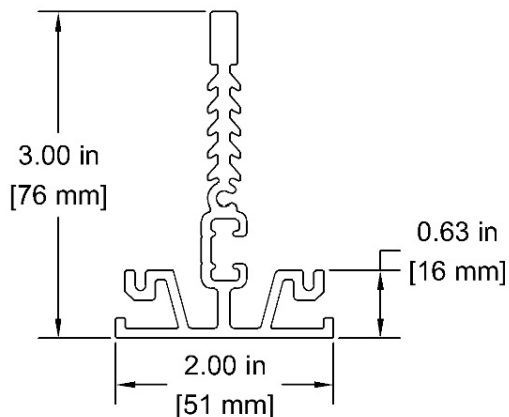

SYSTEM PROPERTIES

Moment of Inertia, Section Modulus & Area

Moment of Inertia, I _{xx}	I _{xx} = 0.88 in ⁴
Section Modulus, S _{xx}	S _{xx} = 0.87 in ³
Total Area	A = 0.97 in ²

Modulus of Elasticity

Aluminum	10,000,000 PSI
Steel	29,000,000 PSI

GENERAL NOTES

1. Deflection Limit: L/175 up to 13.5ft, L/240 + 0.25" over 13.5ft
2. Assume horizontal members provide lateral support
3. Steel moment of inertia converted to polyester, vinyl or aluminum equivalent
4. The design pressure (psf) shall be determined using the controlling load combination of dead, wind, live, and snow loads as applicable.

WIND LOAD CHART FOR 3000T SERIES - PART # 3035

SPAN CHART

**SPAN CHART IS FOR ESTIMATION ONLY.
DO NOT UTILIZE FOR DETAILED DESIGN.
CHART IS BASED ON DEFLECTION ANALYSIS
ONLY**

Mullion Centres (Tributary width) In Meters

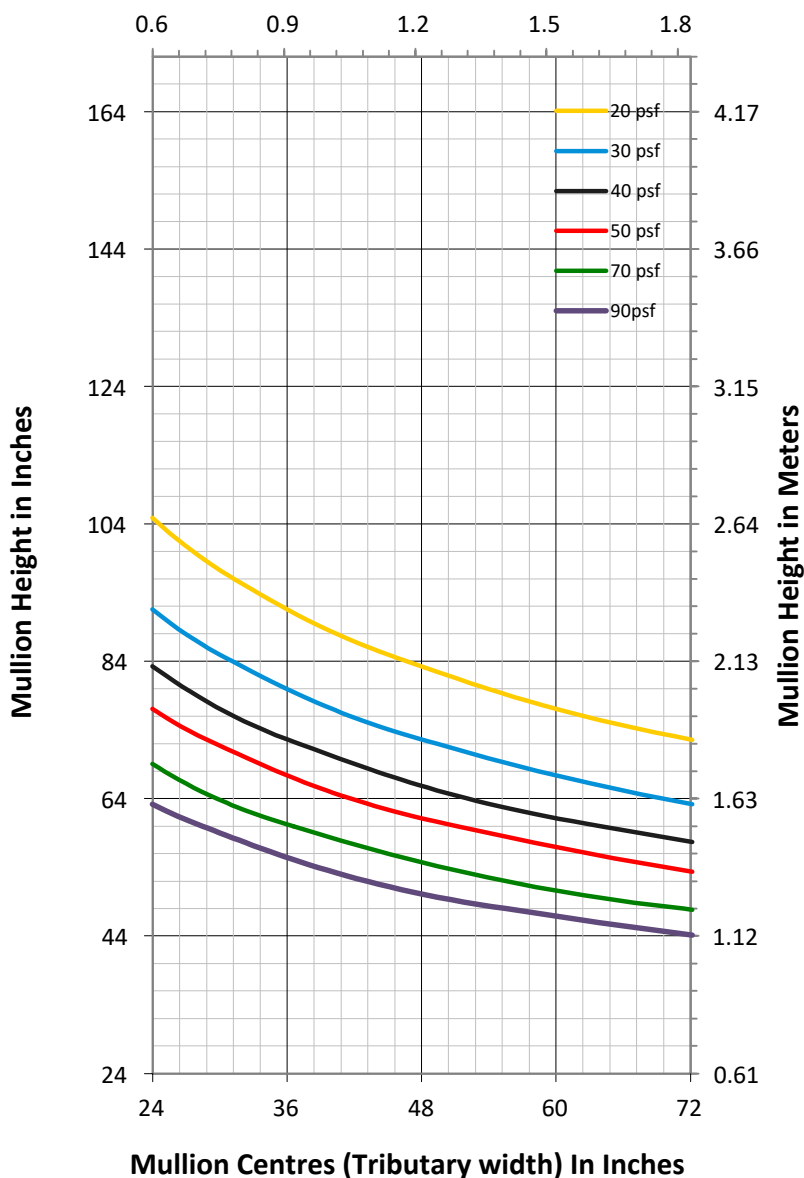

MULLION SECTION

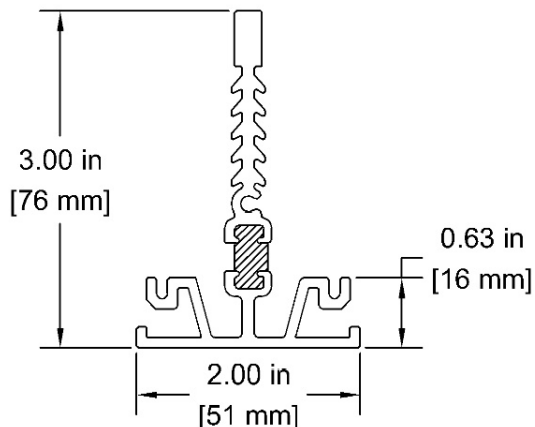

SYSTEM PROPERTIES

Moment of Inertia, Section Modulus & Area

Moment of Inertia, I _{xx}	I _{xx} = 0.88 in ⁴
Section Modulus, S _{xx}	S _{xx} = 0.87 in ³
Total Area	A = 0.95 in ²

Modulus of Elasticity

Aluminum	10,000,000 PSI
Steel	29,000,000 PSI

GENERAL NOTES

1. Deflection Limit: L/175 up to 13.5ft, L/240 + 0.25" over 13.5ft
2. Assume horizontal members provide lateral support
3. Steel moment of inertia converted to polyester, vinyl or aluminum equivalent
4. The design pressure (psf) shall be determined using the controlling load combination of dead, wind, live, and snow loads as applicable.

WIND LOAD CHART FOR 3000 SERIES - PART # 3040

SPAN CHART

SPAN CHART IS FOR ESTIMATION ONLY.
DO NOT UTILIZE FOR DETAILED DESIGN.
CHART IS BASED ON DEFLECTION ANALYSIS
ONLY

Mullion Centres (Tributary width) In Meters

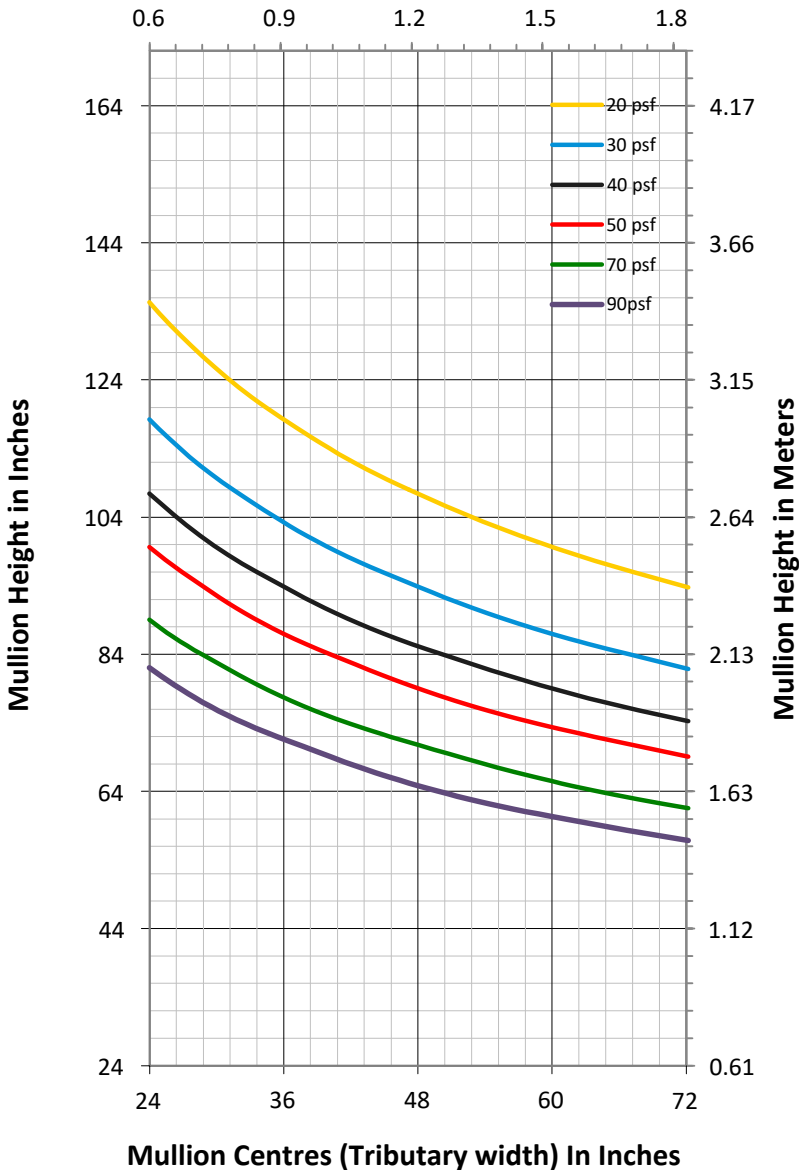

MULLION SECTION

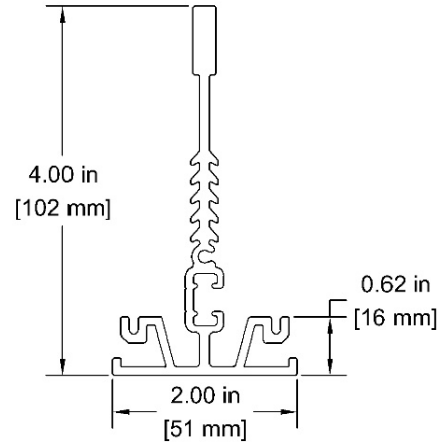

SYSTEM PROPERTIES

Moment of Inertia, Section Modulus & Area

Moment of Inertia, I _{xx}	I _{xx} = 1.88 in ⁴
Section Modulus, S _{xx}	S _{xx} = 0.73 in ³
Total Area	A = 1.11 in ²

Modulus of Elasticity

Aluminum	10,000,000 PSI
Steel	29,000,000 PSI

GENERAL NOTES

1. Deflection Limit: L/175 up to 13.5ft, L/240 + 0.25" over 13.5ft
2. Assume horizontal members provide lateral support
3. Steel moment of inertia converted to polyester, vinyl or aluminum equivalent
4. The design pressure (psf) shall be determined using the controlling load combination of dead, wind, live, and snow loads as applicable.

WIND LOAD CHART FOR 3000T SERIES - PART # 3045

SPAN CHART

MULLION SECTION

**SPAN CHART IS FOR ESTIMATION ONLY.
DO NOT UTILIZE FOR DETAILED DESIGN.
CHART IS BASED ON DEFLECTION ANALYSIS
ONLY**

Mullion Centres (Tributary width) In Meters

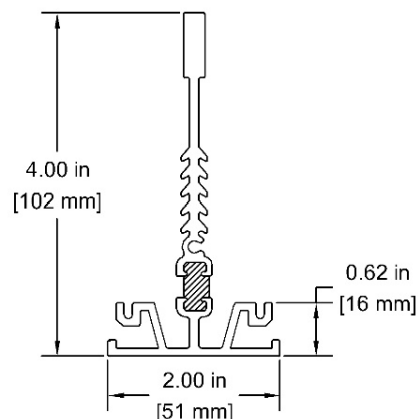
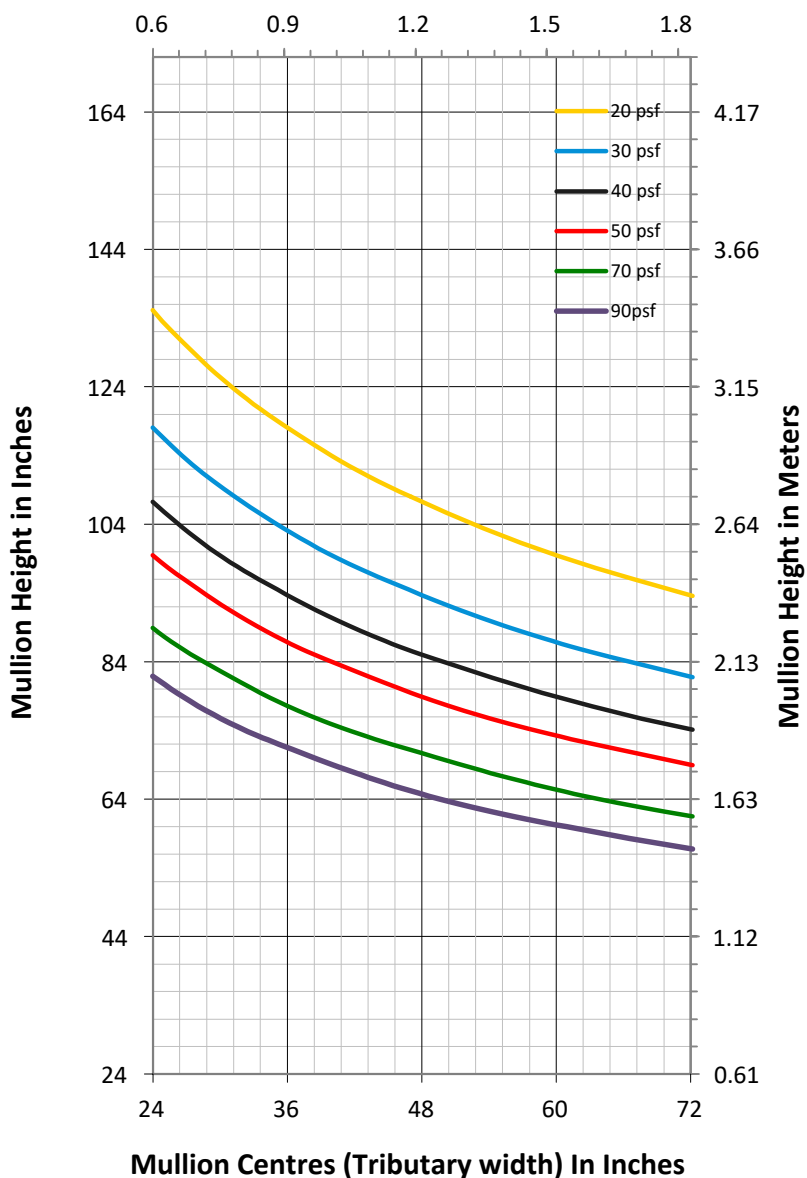

SYSTEM PROPERTIES

Moment of Inertia, Section Modulus & Area

Moment of Inertia, I _{xx}	I _{xx} = 1.87 in ⁴
Section Modulus, S _{xx}	S _{xx} = 0.73 in ³
Total Area	A = 1.09 in ²

Modulus of Elasticity

Aluminum	10,000,000 PSI
Steel	29,000,000 PSI

GENERAL NOTES

1. Deflection Limit: L/175 up to 13.5ft, L/240 + 0.25" over 13.5ft
2. Assume horizontal members provide lateral support
3. Steel moment of inertia converted to polyester, vinyl or aluminum equivalent
4. The design pressure (psf) shall be determined using the controlling load combination of dead, wind, live, and snow loads as applicable.



3400 SERIES

RAFTER-PURLIN SKYLIGHT SYSTEMS
2" (50.8 mm) BASE WIDTH

G

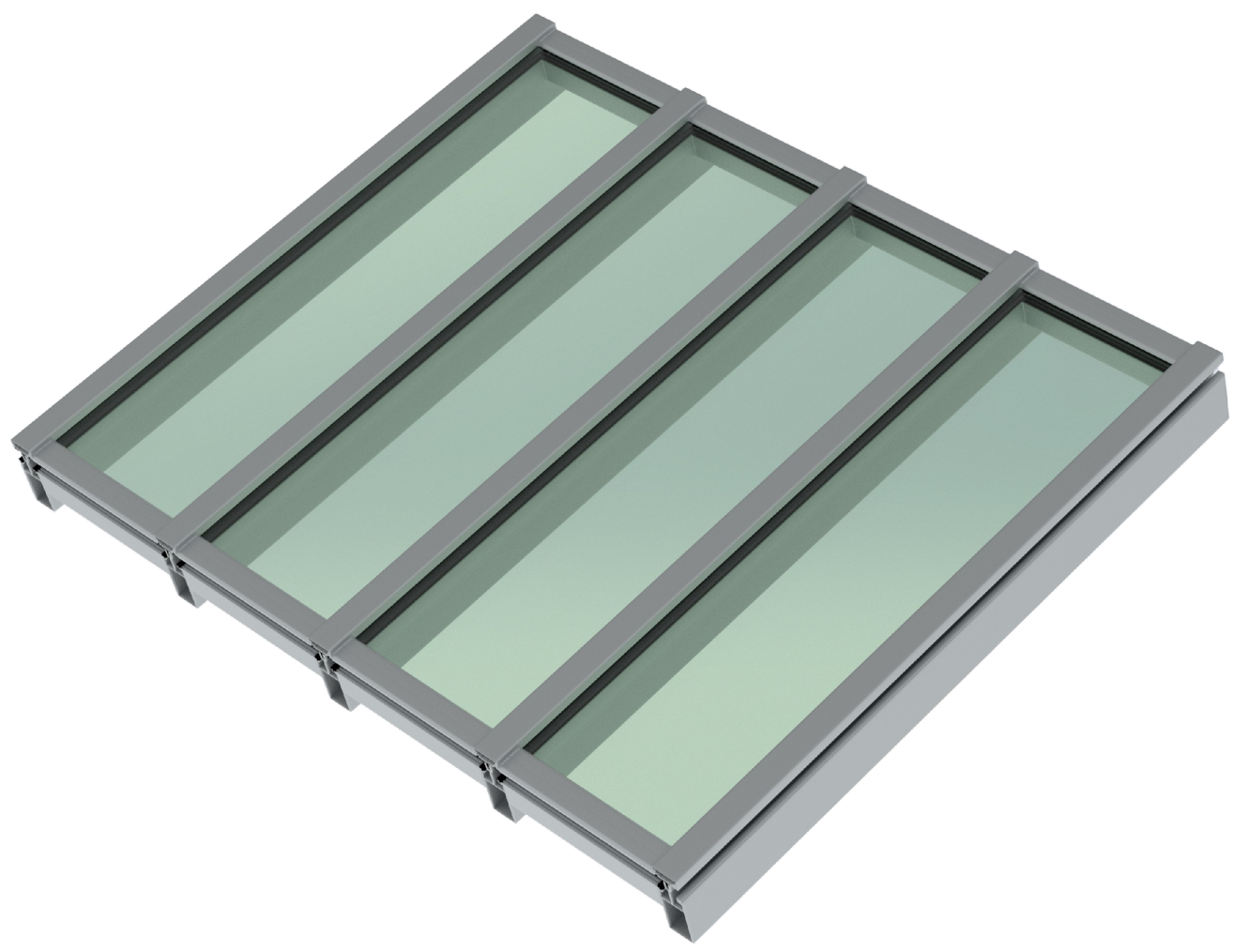



COMPONENTS

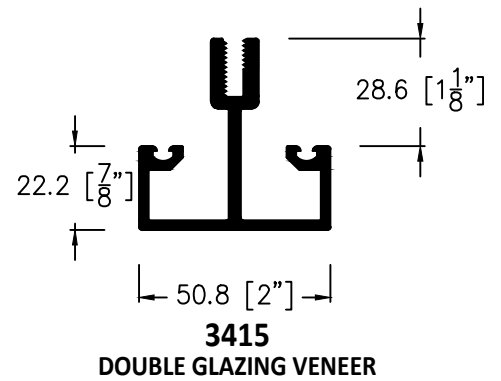
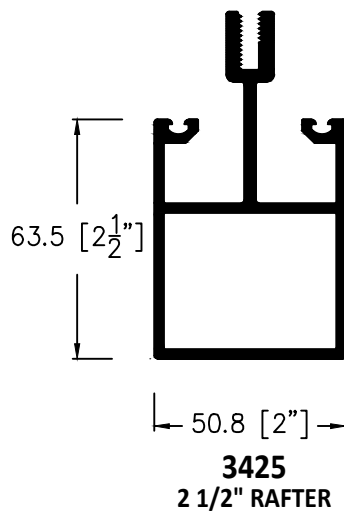
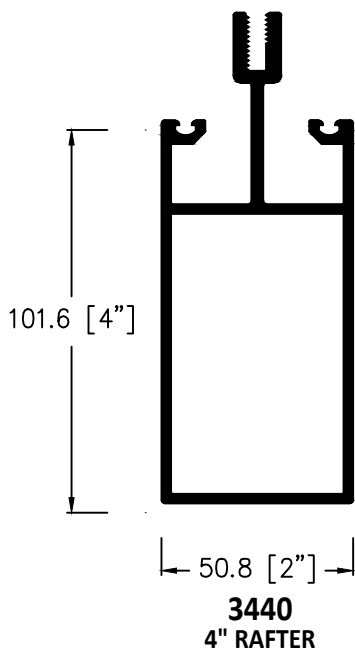
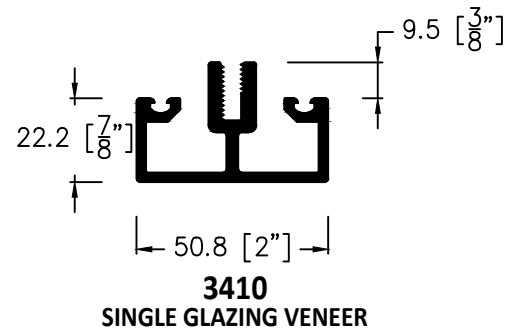
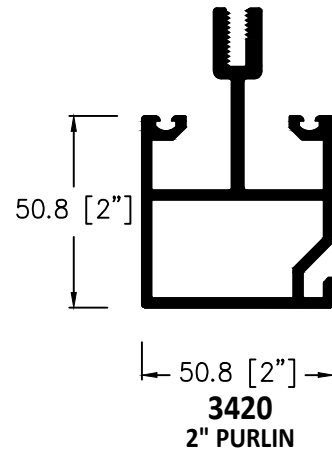
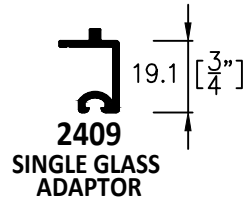
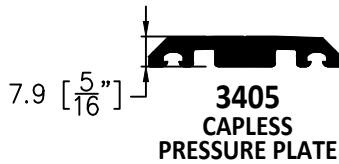
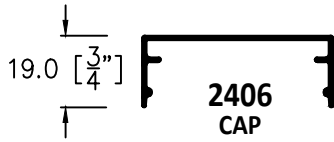



PICTORIAL (3D) PRESENTATION

PARTS

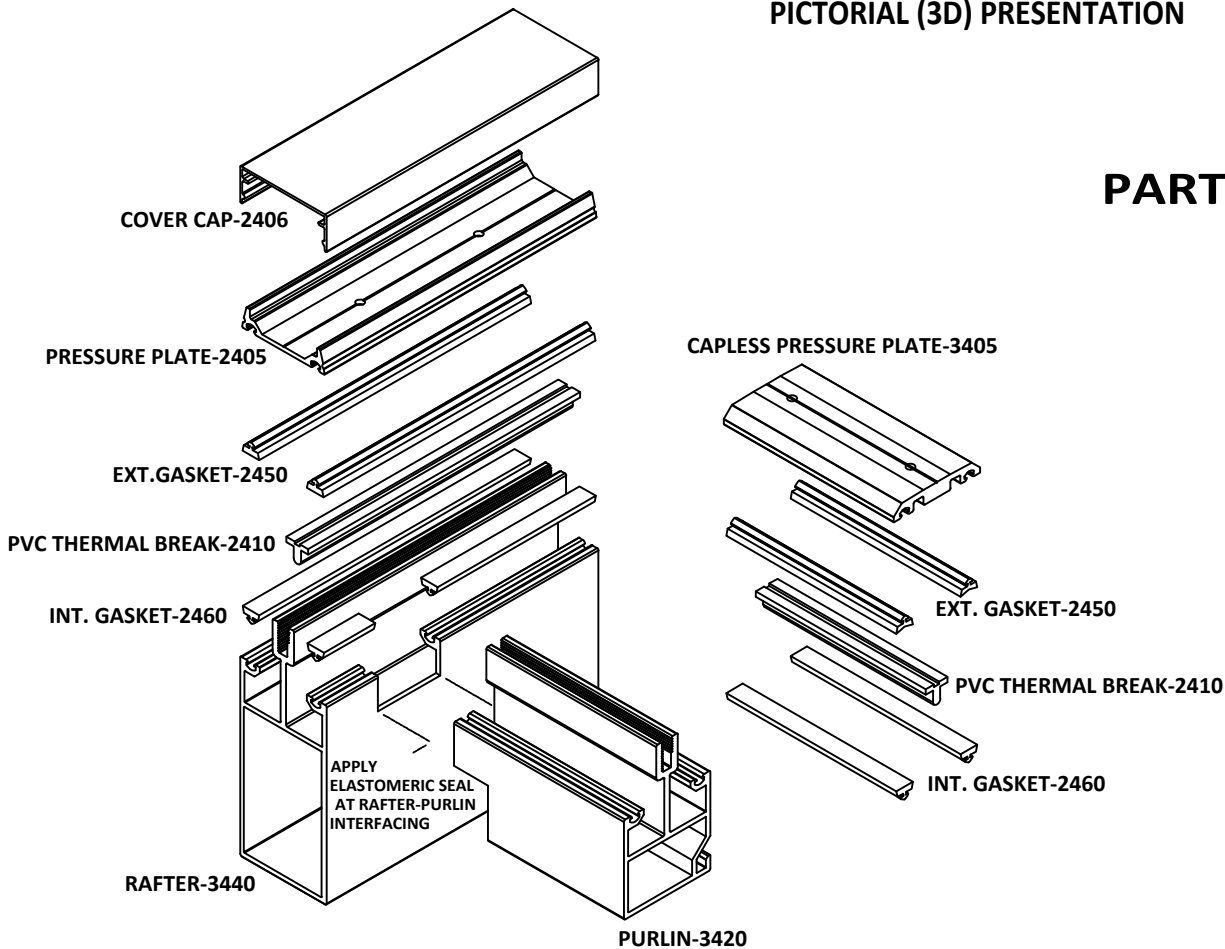

ASSEMBLY

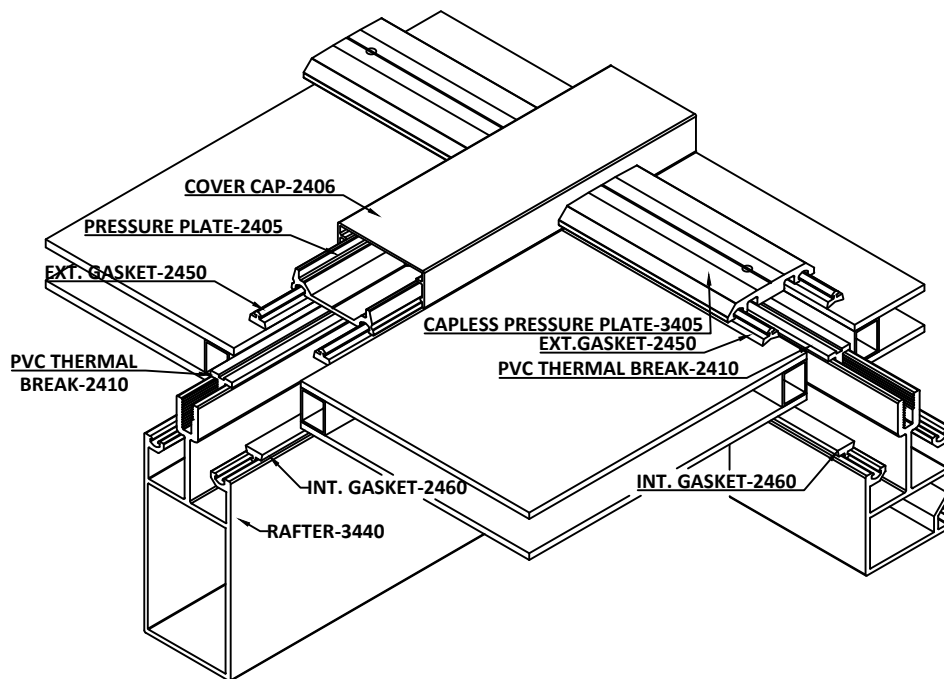



DETAILS

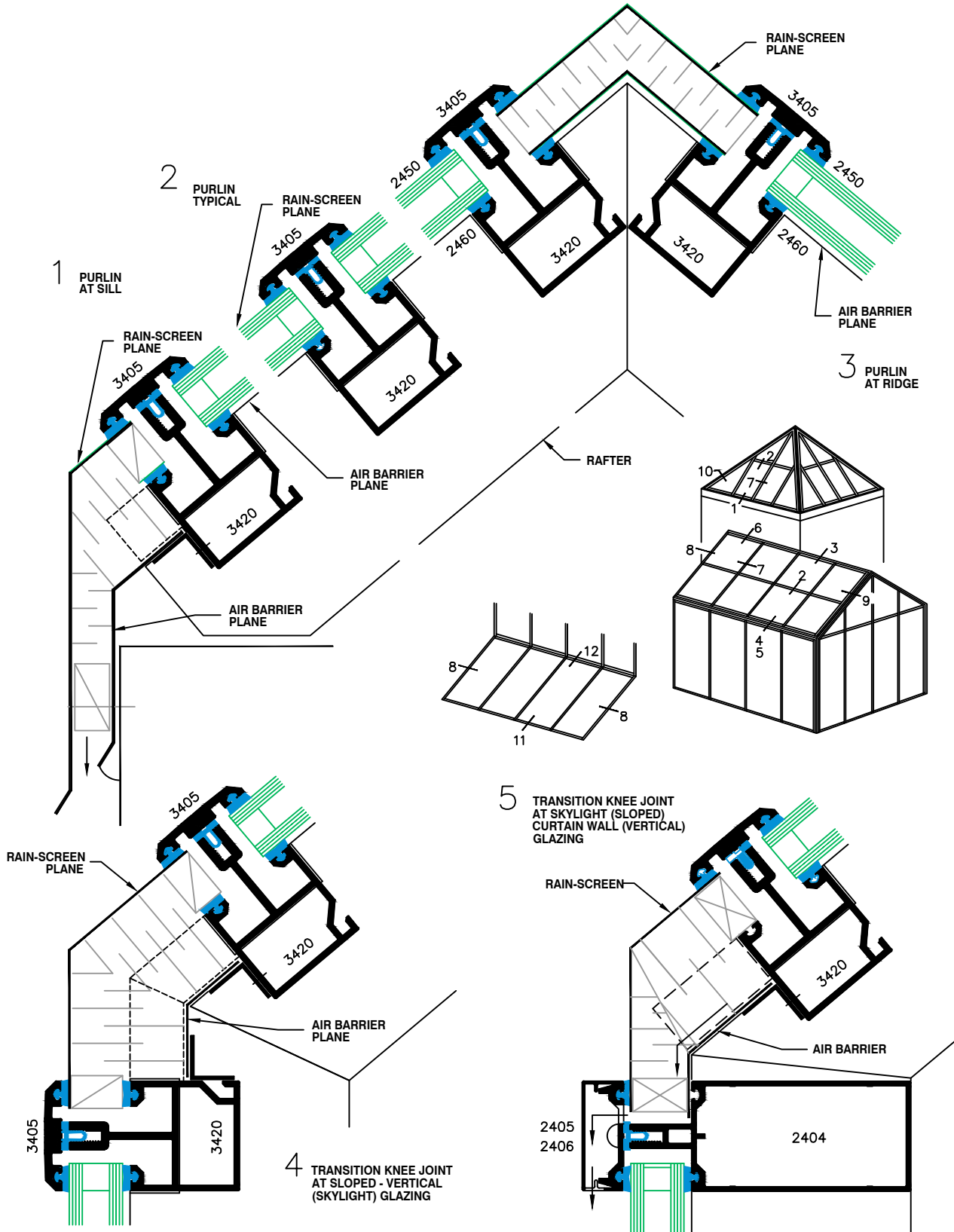



DETAILS

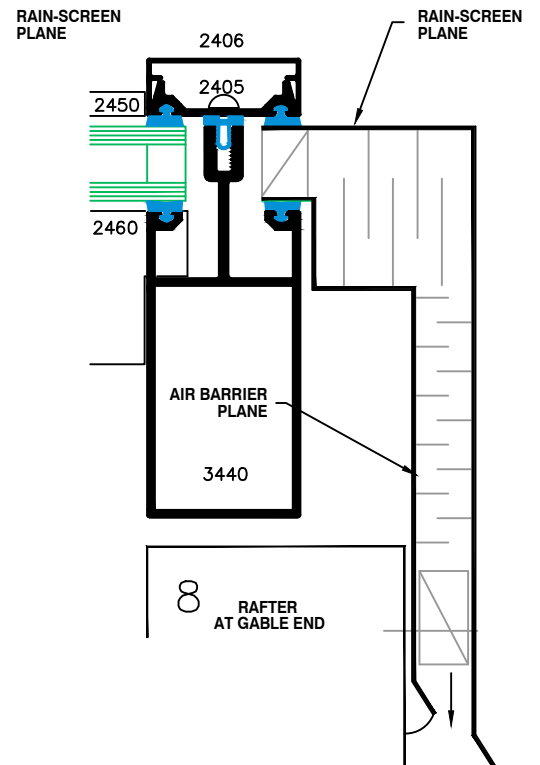
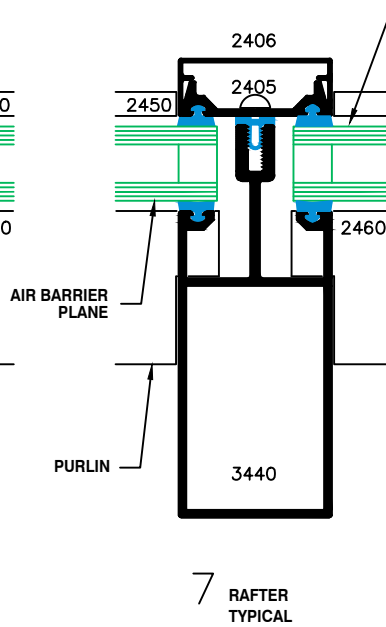
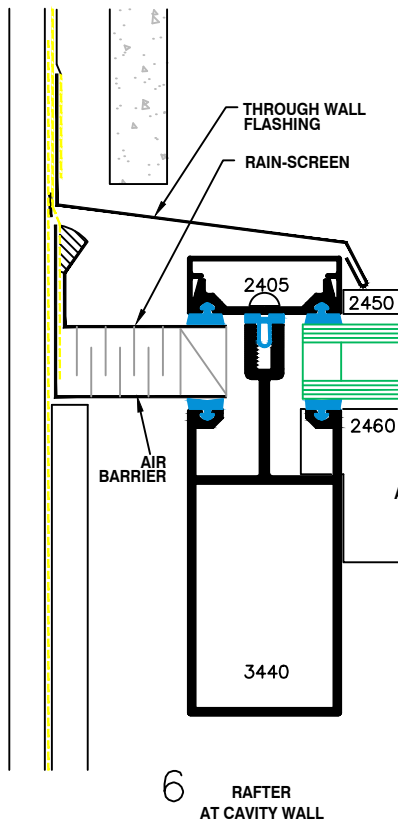
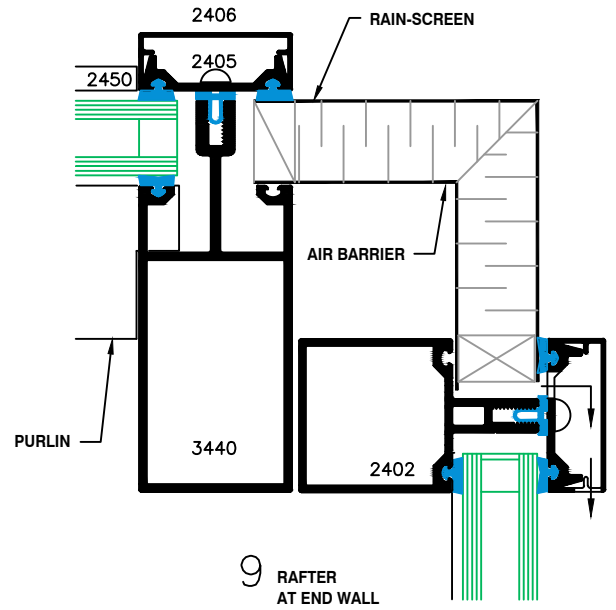
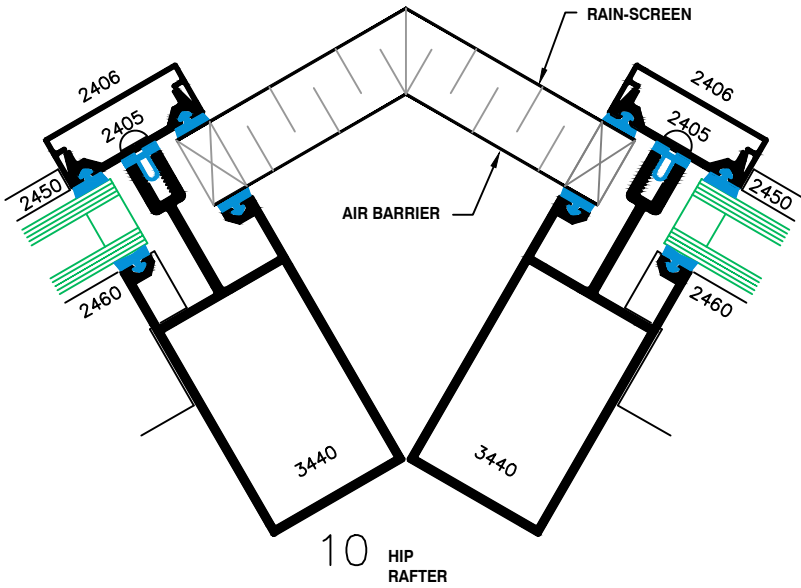



**METRO
ALUMINUM**
Products Ltd.

3400 SERIES
RAFTER-PURLIN SKYLIGHT SYSTEMS
2" (50.8 mm) BASE WIDTH

**G
08C**

SUGGESTED INTERFACE DETAILS

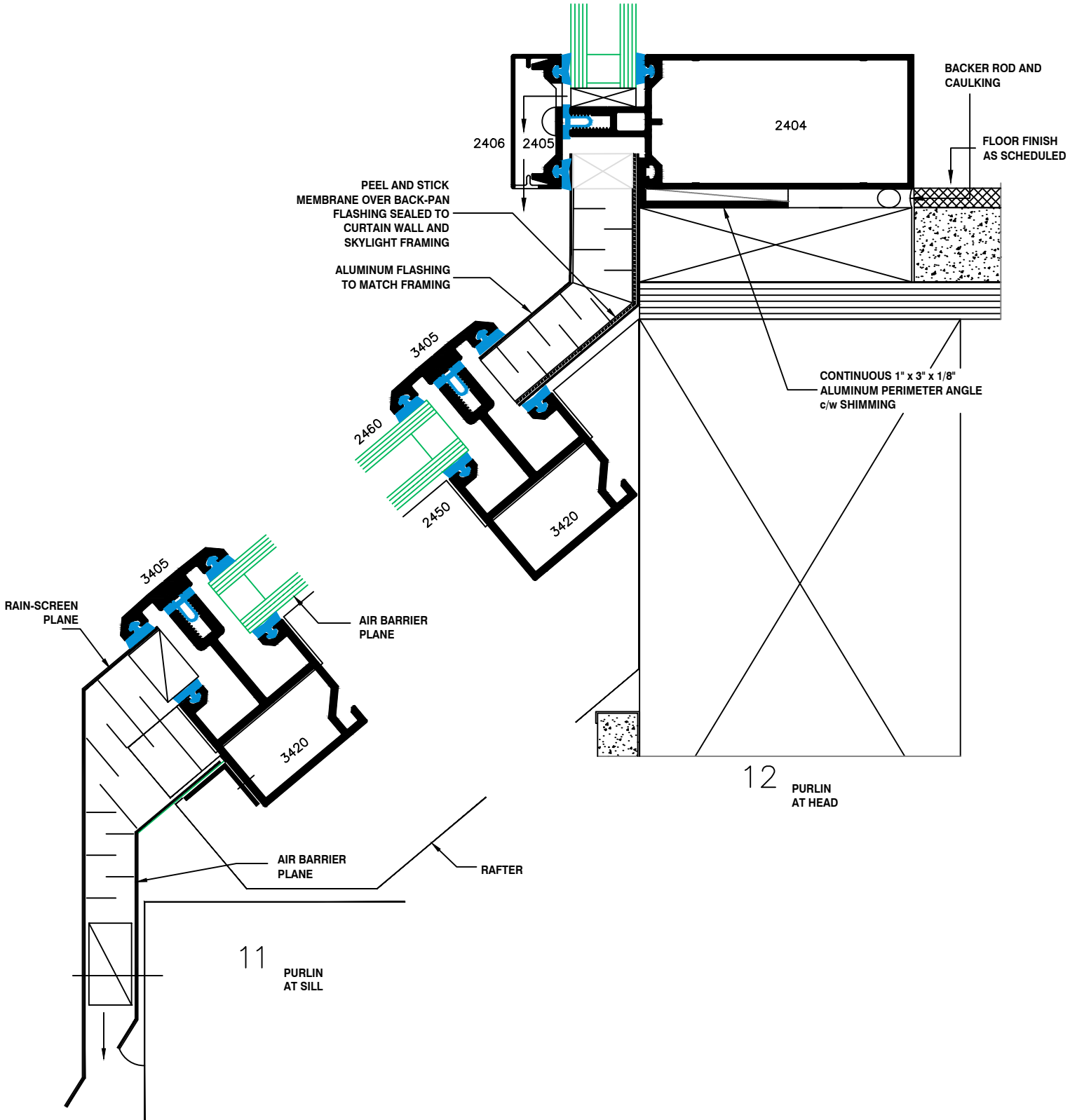

DETAILS

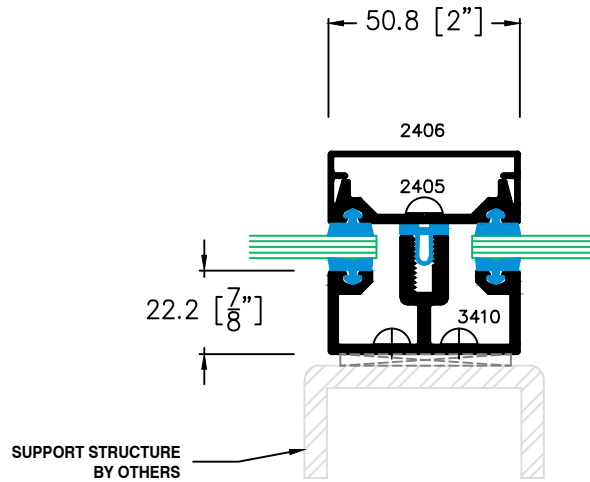

1 3 SINGLE GLAZING VENEER

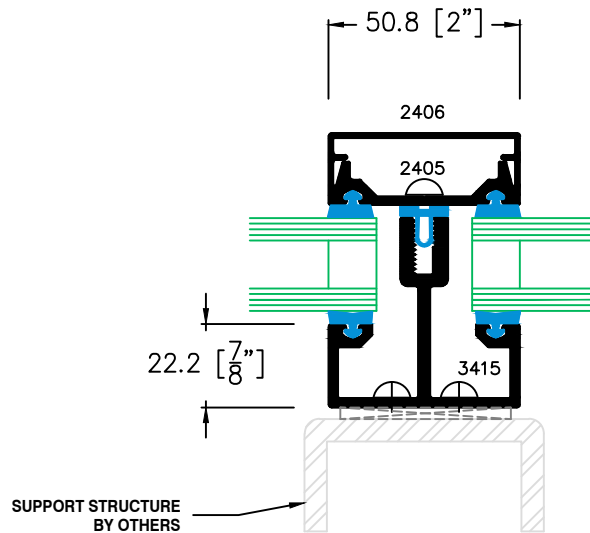

1 4 DOUBLE GLAZING VENEER

WIND LOAD CHART FOR 3400 SERIES - PART # 3420

SPAN CHART

**SPAN CHART IS FOR ESTIMATION ONLY.
DO NOT UTILIZE FOR DETAILED DESIGN.
CHART IS BASED ON DEFLECTION ANALYSIS
ONLY**

Mullion Centres (Tributary width) In Meters

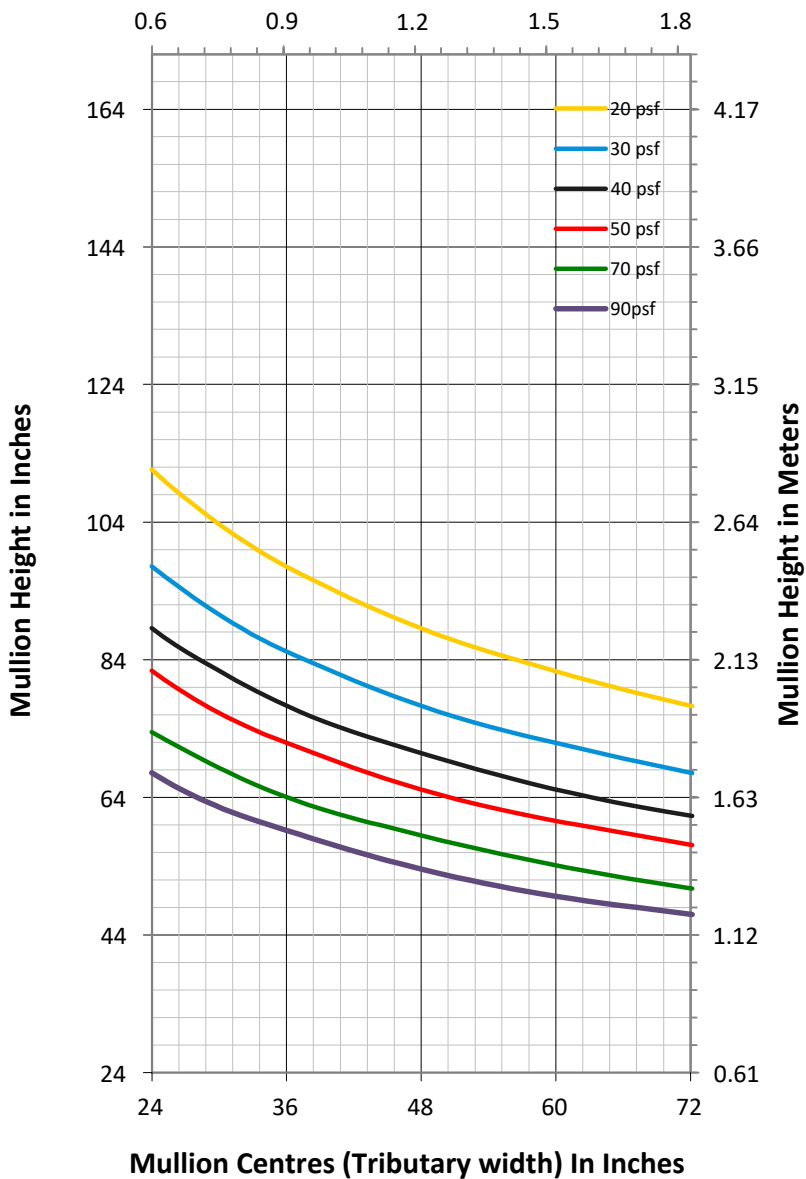

MULLION SECTION

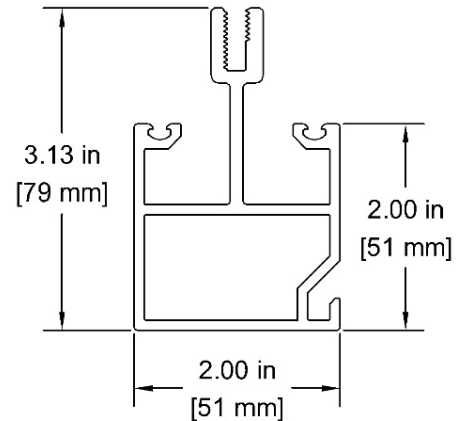

SYSTEM PROPERTIES

Moment of Inertia, Section Modulus & Area

Moment of Inertia, I _{xx}	I _{xx} = 1.06 in ⁴
Section Modulus, S _{xx}	S _{xx} = 0.60 in ³
Total Area	A = 1.28 in ²
Modulus of Elasticity	
Aluminum	10,000,000 PSI
Steel	29,000,000 PSI

GENERAL NOTES

1. Deflection Limit: L/175 up to 13.5ft, L/240 + 0.25" over 13.5ft
2. Assume horizontal members provide lateral support
3. Steel moment of inertia converted to polyester, vinyl or aluminum equivalent
4. The design pressure (psf) shall be determined using the controlling load combination of dead, wind, live, and snow loads as applicable.

WIND LOAD CHART FOR 3400 SERIES - PART # 3425

SPAN CHART

**SPAN CHART IS FOR ESTIMATION ONLY.
DO NOT UTILIZE FOR DETAILED DESIGN.
CHART IS BASED ON DEFLECTION ANALYSIS
ONLY**

Mullion Centres (Tributary width) In Meters

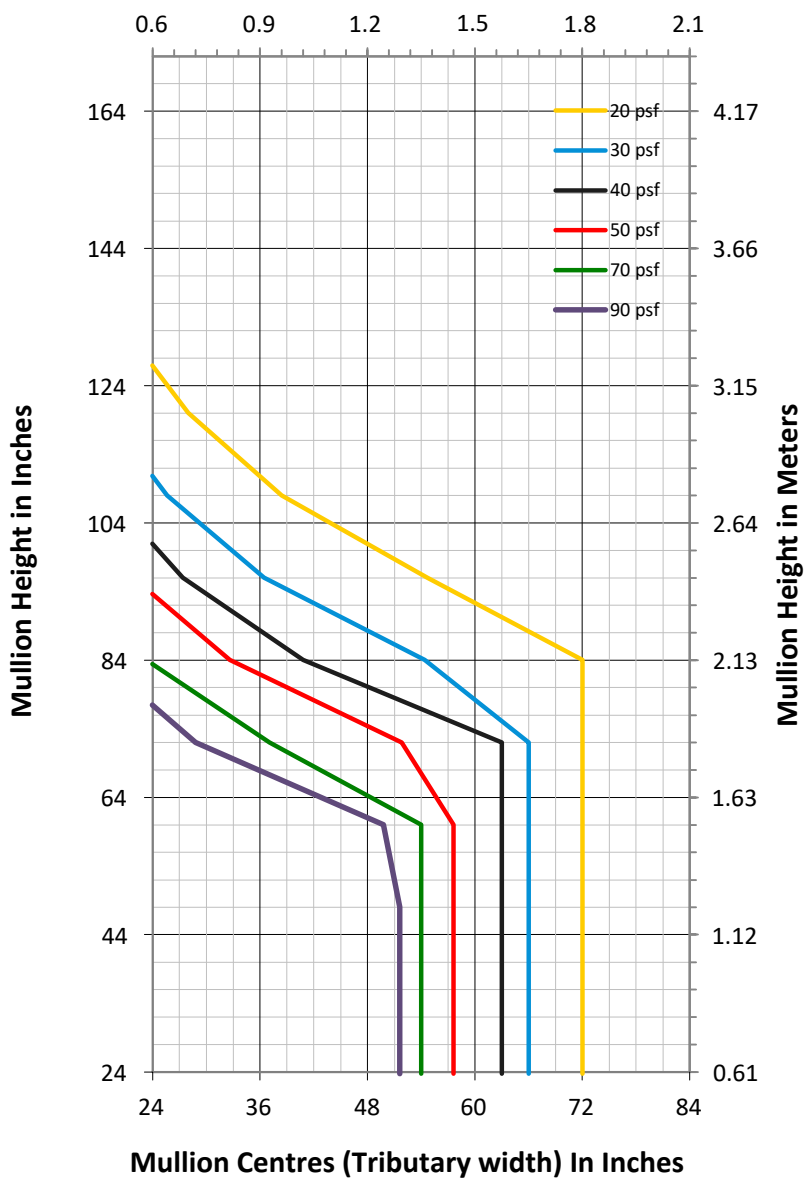

MULLION SECTION

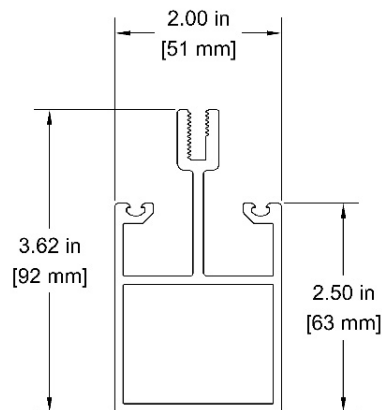

SYSTEM PROPERTIES

Moment of Inertia, Section Modulus & Area

Moment of Inertia, I _{xx}	I _{xx} = 1.53 in ⁴
Section Modulus, S _{xx}	S _{xx} = 0.79 in ³
Total Area	A = 1.36 in ²

Modulus of Elasticity

Aluminum	10,000,000 PSI
Steel	29,000,000 PSI

GENERAL NOTES

1. Deflection Limit: L/175 up to 13.5ft, L/240 + 0.25" over 13.5ft
2. Assume horizontal members provide lateral support
3. Steel moment of inertia converted to polyester, vinyl or aluminum equivalent
4. The design pressure (psf) shall be determined using the controlling load combination of dead, wind, live, and snow loads as applicable.

WIND LOAD CHART FOR 3400 SERIES - PART # 3440

SPAN CHART

**SPAN CHART IS FOR ESTIMATION ONLY.
DO NOT UTILIZE FOR DETAILED DESIGN.
CHART IS BASED ON DEFLECTION ANALYSIS
ONLY**

Mullion Centres (Tributary width) In Meters

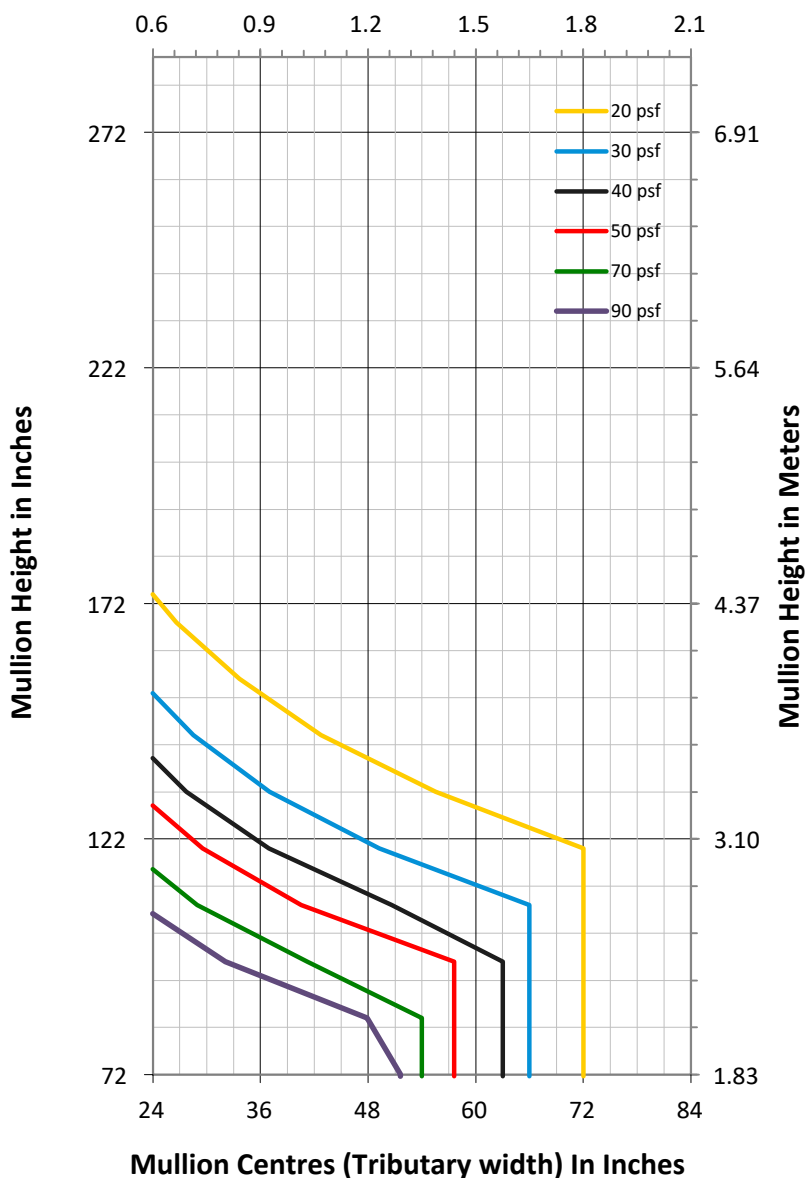

MULLION SECTION

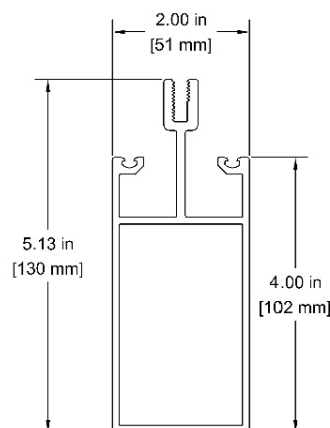

SYSTEM PROPERTIES

Moment of Inertia, Section Modulus & Area

Moment of Inertia, Ixx	Ixx = 4.04 in ⁴
Section Modulus, Sxx	Sxx = 1.57 in ³
Total Area	A = 1.66 in ²

Modulus of Elasticity

Aluminum	10,000,000 PSI
Steel	29,000,000 PSI

GENERAL NOTES

1. Deflection Limit: L/175 up to 13.5ft, L/240 + 0.25" over 13.5ft
2. Assume horizontal members provide lateral support
3. Steel moment of inertia converted to polyester, vinyl or aluminum equivalent
4. The design pressure (psf) shall be determined using the controlling load combination of dead, wind, live, and snow loads as applicable.

WIND LOAD CHART FOR 3400 SERIES - PART # 3410

SPAN CHART

SPAN CHART IS FOR ESTIMATION ONLY.
DO NOT UTILIZE FOR DETAILED DESIGN.
CHART IS BASED ON DEFLECTION ANALYSIS
ONLY

Mullion Centres (Tributary width) In Meters

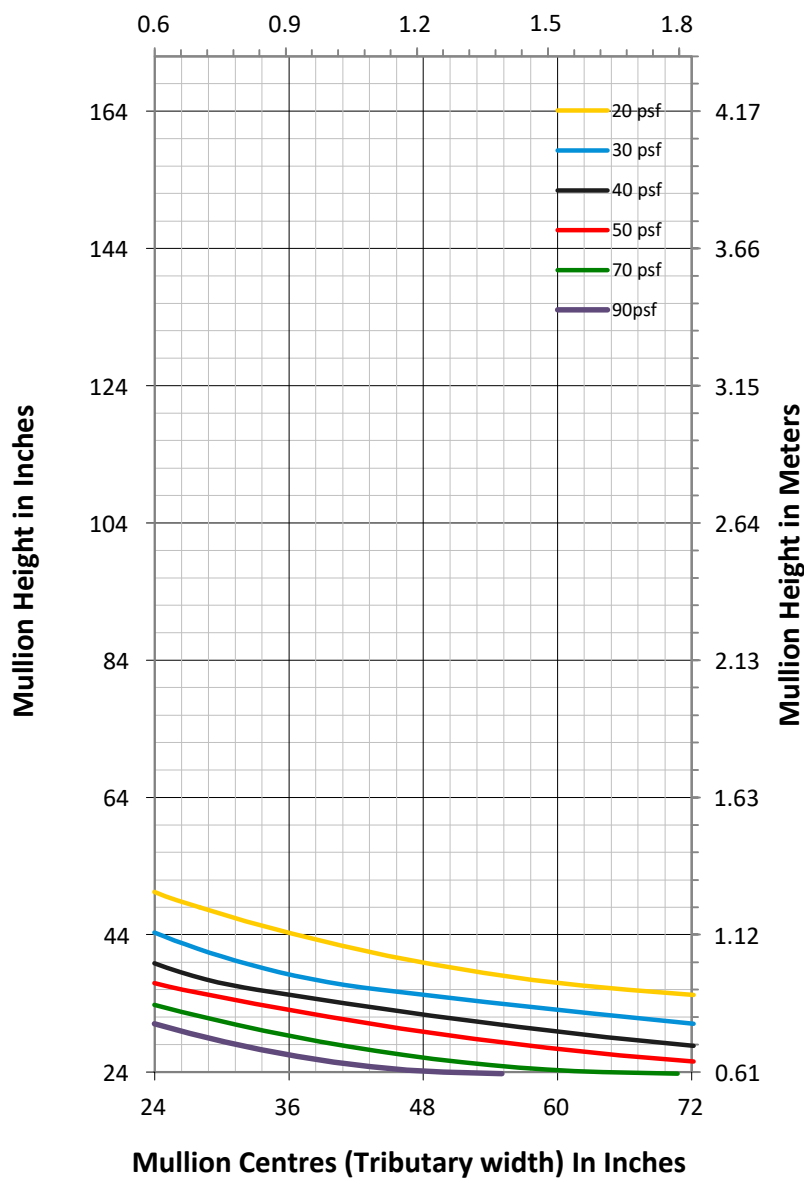

MULLION SECTION

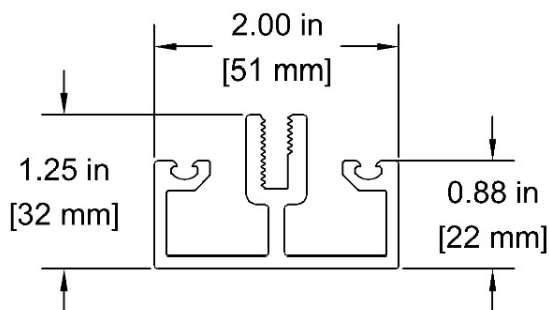

SYSTEM PROPERTIES

Moment of Inertia, Section Modulus & Area

Moment of Inertia, Ixx	Ixx = 0.10 in ⁴
Section Modulus, Sxx	Sxx = 0.13 in ³
Total Area	A = 0.75 in ²

Modulus of Elasticity

Aluminum	10,000,000 PSI
Steel	29,000,000 PSI

GENERAL NOTES

1. Deflection Limit: L/175 up to 13.5ft, L/240 + 0.25" over 13.5ft
2. Assume horizontal members provide lateral support
3. Steel moment of inertia converted to polyester, vinyl or aluminum equivalent
4. The design pressure (psf) shall be determined using the controlling load combination of dead, wind, live, and snow loads as applicable.

WIND LOAD CHART FOR 3400 SERIES - PART # 3415

SPAN CHART

**SPAN CHART IS FOR ESTIMATION ONLY.
DO NOT UTILIZE FOR DETAILED DESIGN.
CHART IS BASED ON DEFLECTION ANALYSIS
ONLY**

Mullion Centres (Tributary width) In Meters

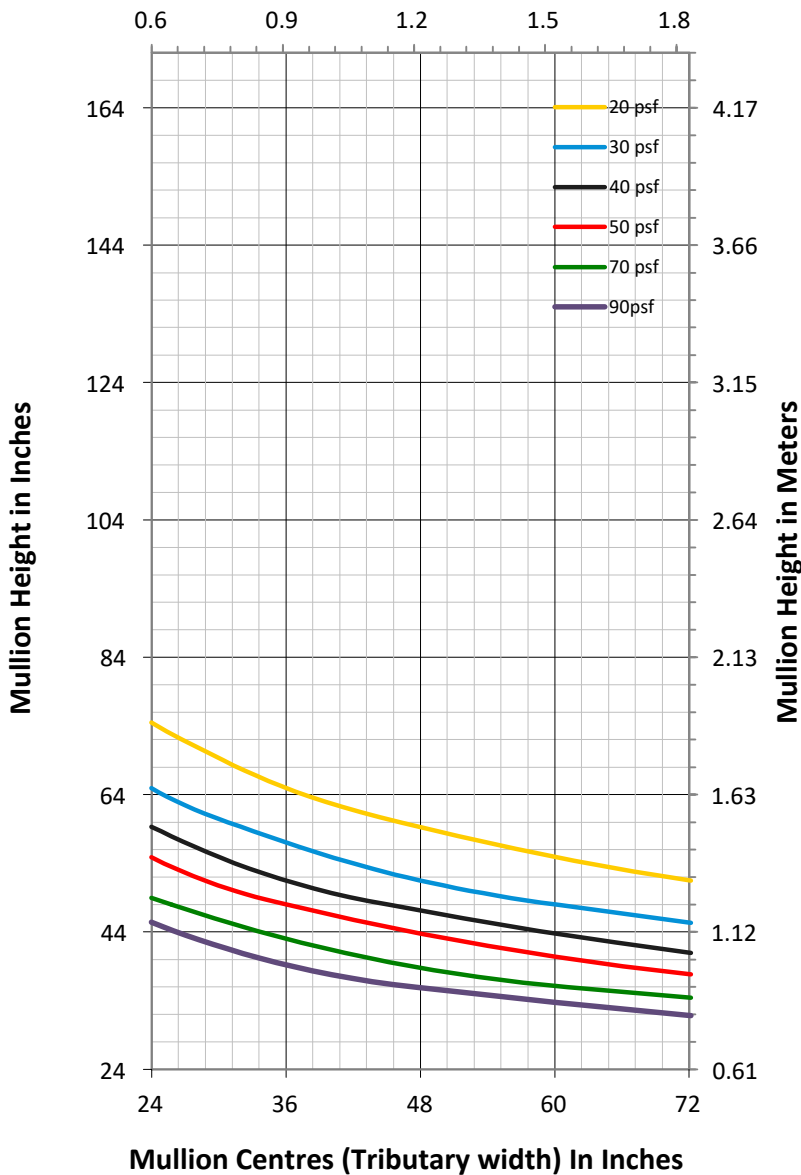

MULLION SECTION

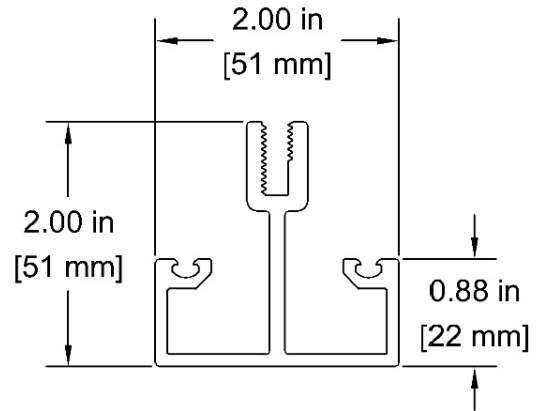

SYSTEM PROPERTIES

Moment of Inertia, Section Modulus & Area

Moment of Inertia, I _{xx}	I _{xx} = 0.32 in ⁴
Section Modulus, S _{xx}	S _{xx} = 0.26 in ³
Total Area	A = 0.84 in ²

Modulus of Elasticity

Aluminum	10,000,000 PSI
Steel	29,000,000 PSI

GENERAL NOTES

1. Deflection Limit: L/175 up to 13.5ft, L/240 + 0.25" over 13.5ft
2. Assume horizontal members provide lateral support
3. Steel moment of inertia converted to polyester, vinyl or aluminum equivalent
4. The design pressure (psf) shall be determined using the controlling load combination of dead, wind, live, and snow loads as applicable.



**METRO
ALUMINUM**

Products Ltd.

3400T SERIES

T/B RAFTER-PURLIN SKYLIGHT SYSTEMS
2" (50.8 mm) BASE WIDTH

G

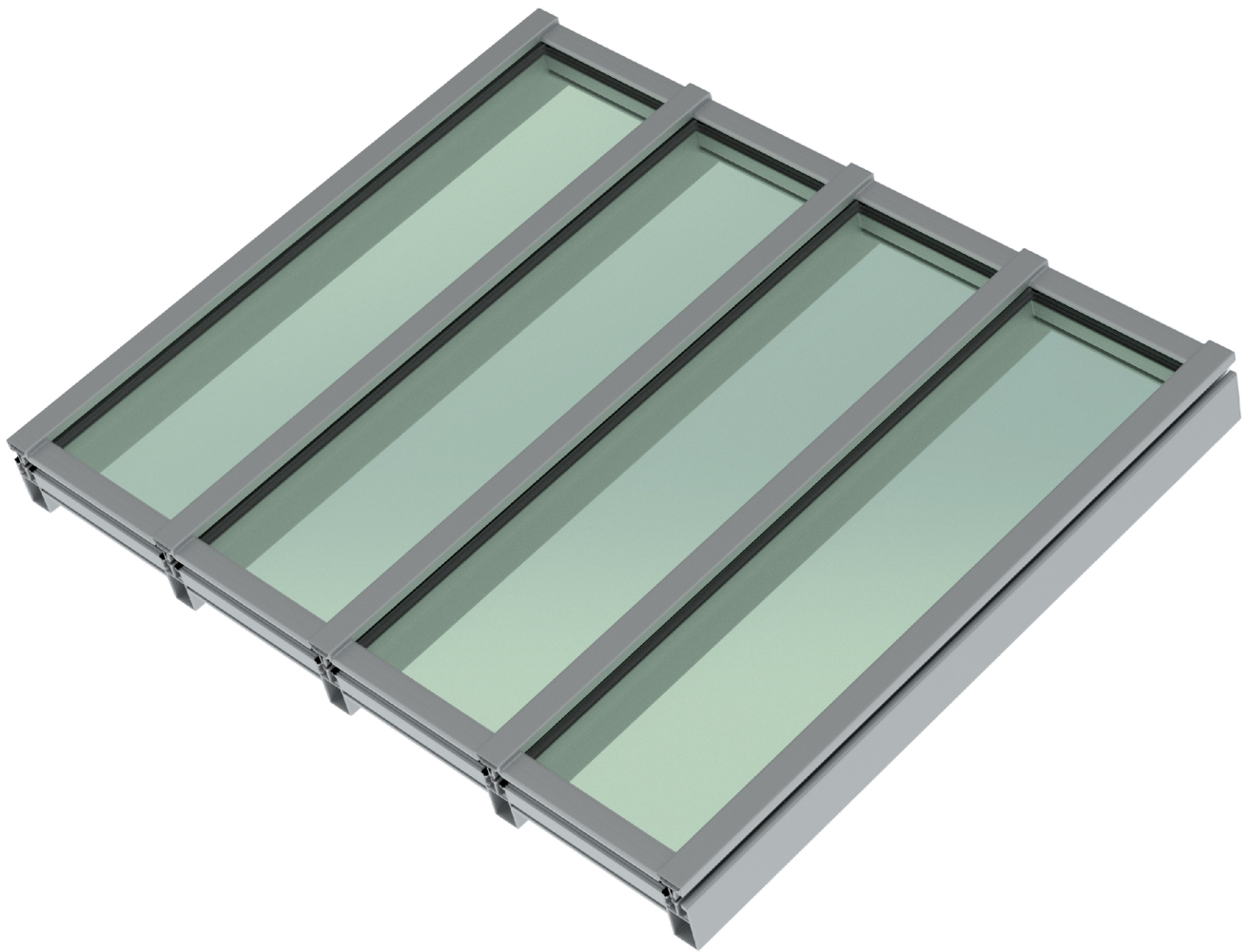



COMPONENTS

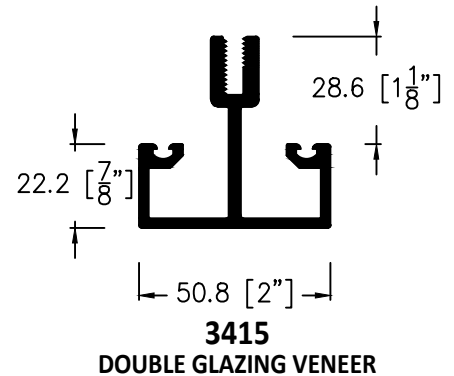
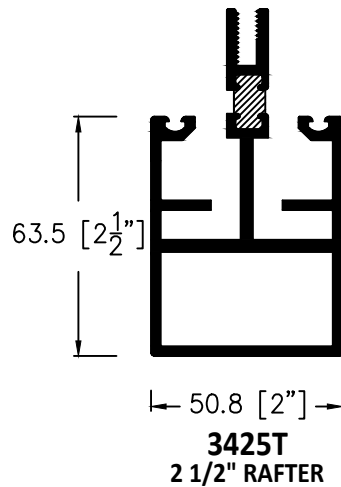
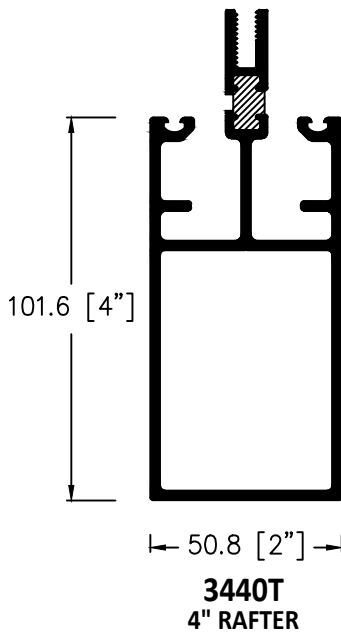
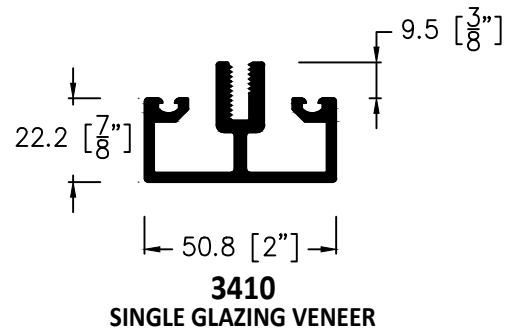
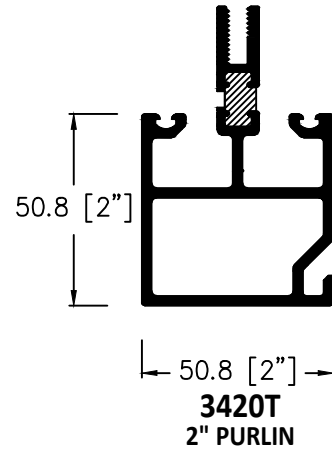
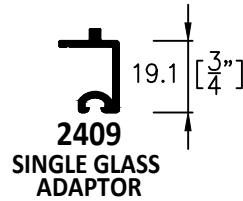
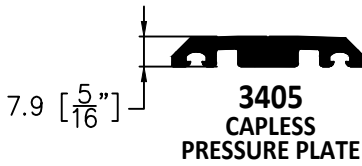
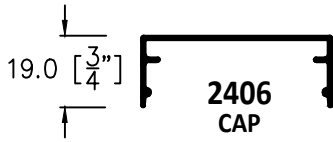



PICTORIAL (3D) PRESENTATION

PARTS

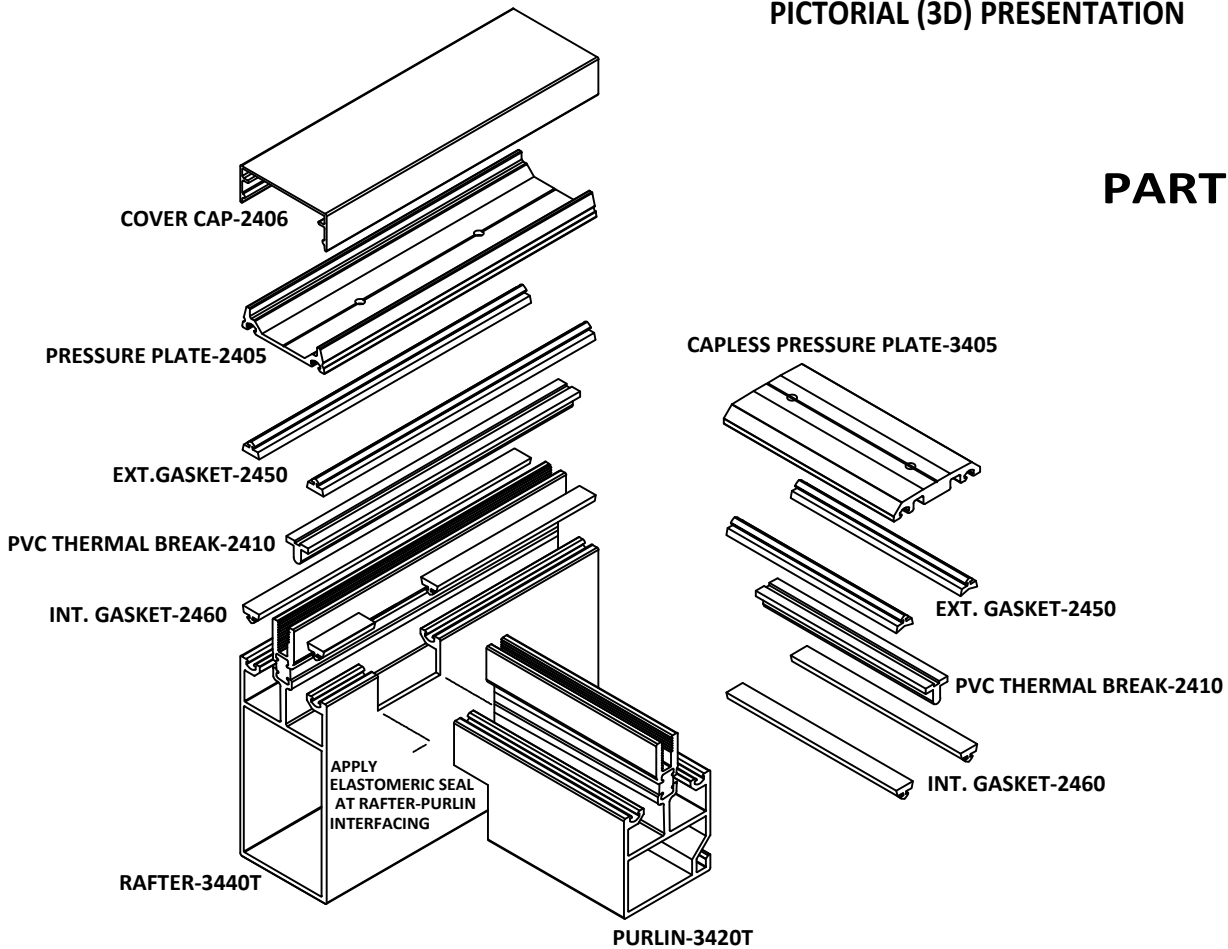

ASSEMBLY

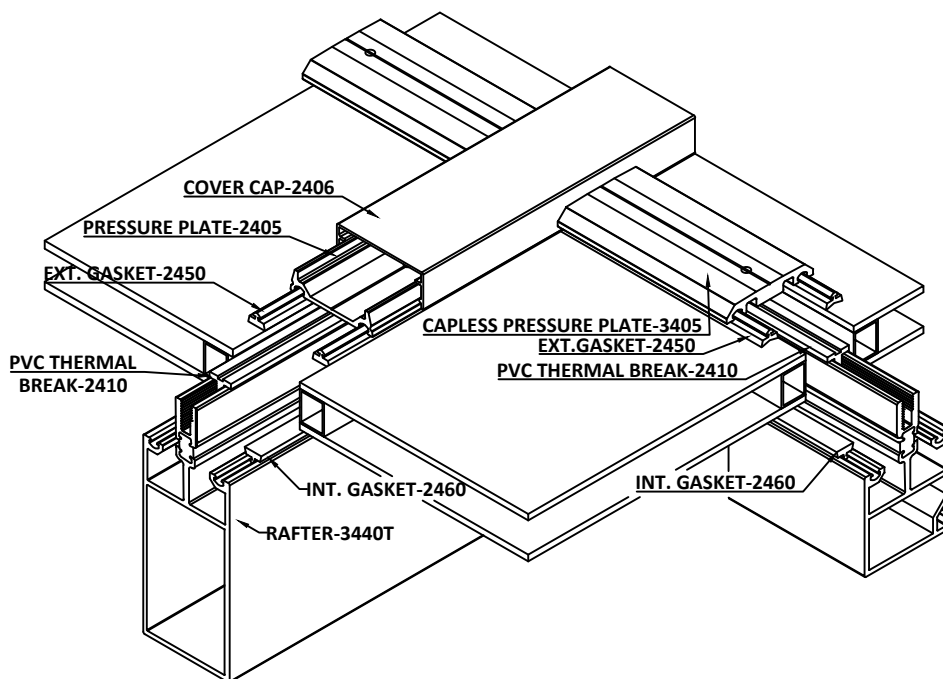



DETAILS

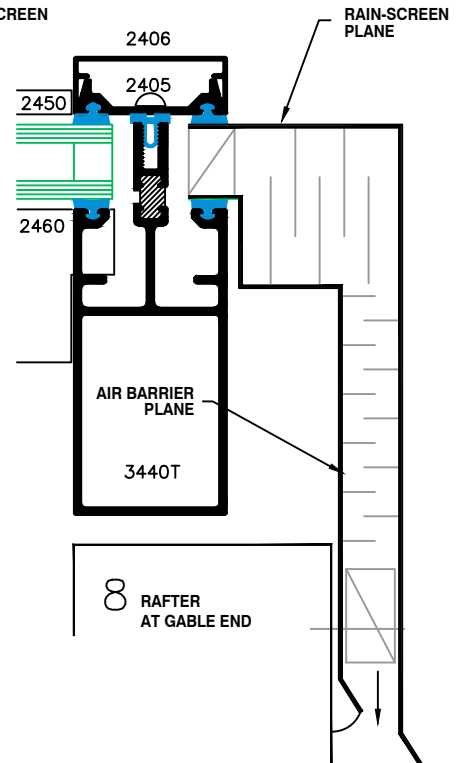
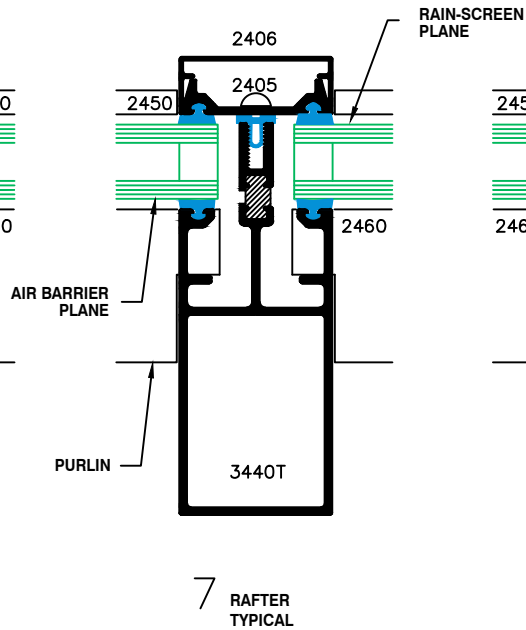
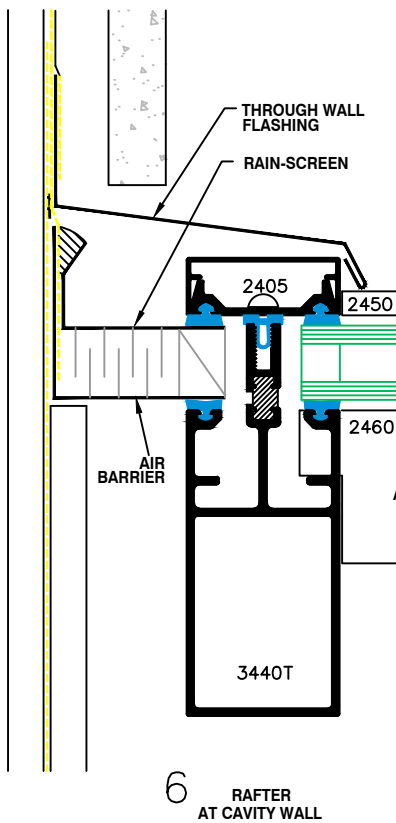
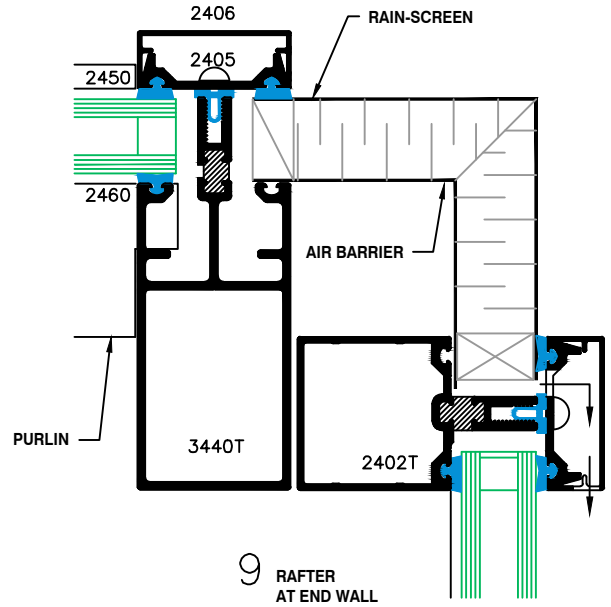
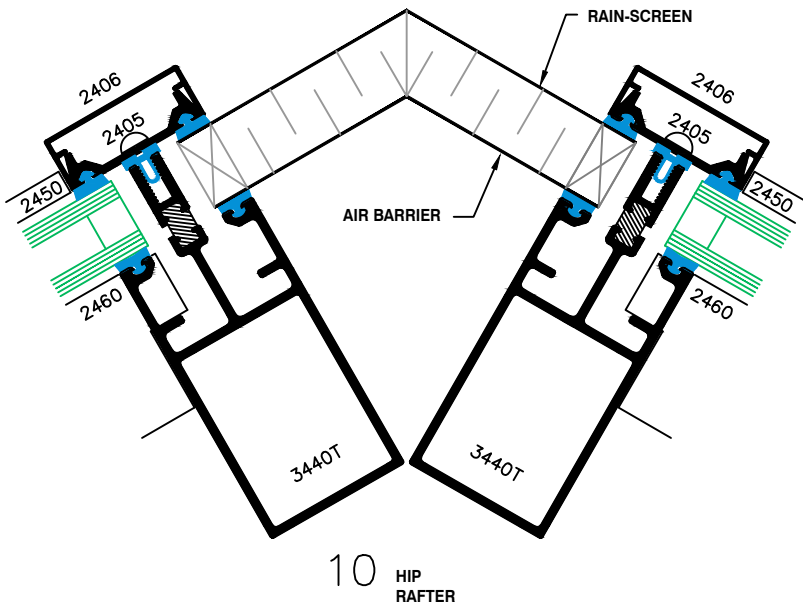



**METRO
ALUMINUM**
Products Ltd.

3400T SERIES

T/B RAFTER-PURLIN SKYLIGHT SYSTEMS
2" (50.8 mm) BASE WIDTH

**G
15C**

SUGGESTED INTERFACE DETAILS

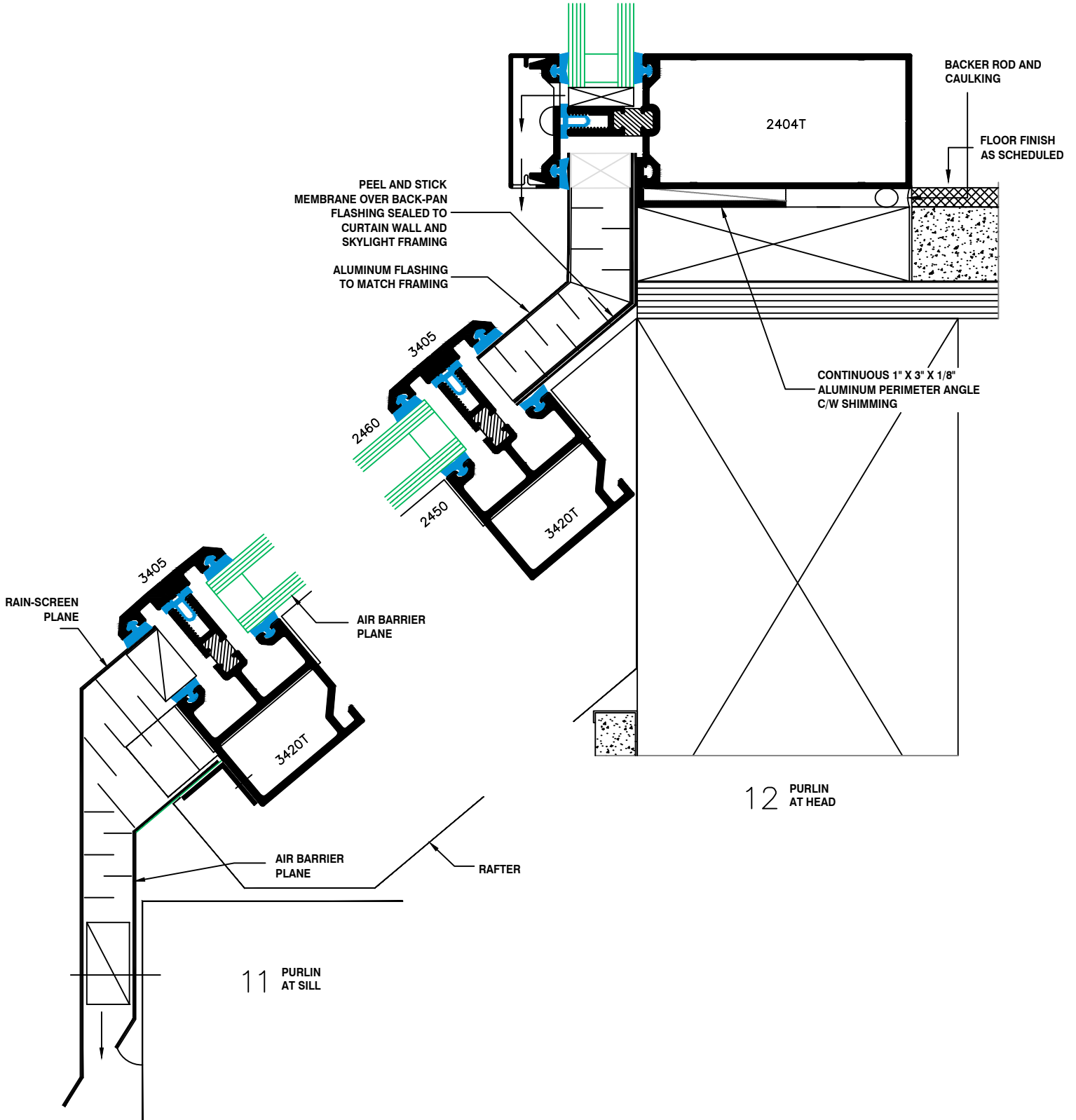

DETAILS

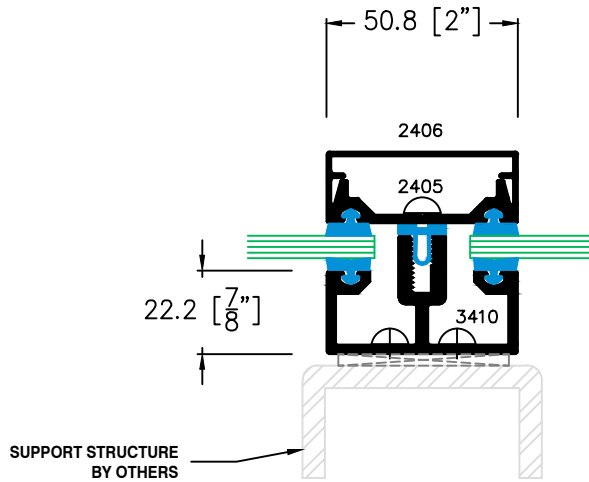

1 3 SINGLE GLAZING VENEER

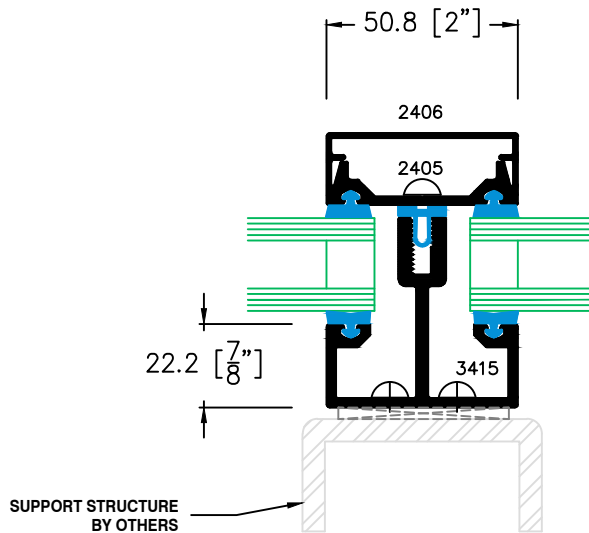

1 4 DOUBLE GLAZING VENEER

WIND LOAD CHART FOR 3400T SERIES - PART # 3420T

SPAN CHART

**SPAN CHART IS FOR ESTIMATION ONLY.
DO NOT UTILIZE FOR DETAILED DESIGN.
CHART IS BASED ON DEFLECTION ANALYSIS
ONLY**

Mullion Centres (Tributary width) In Meters

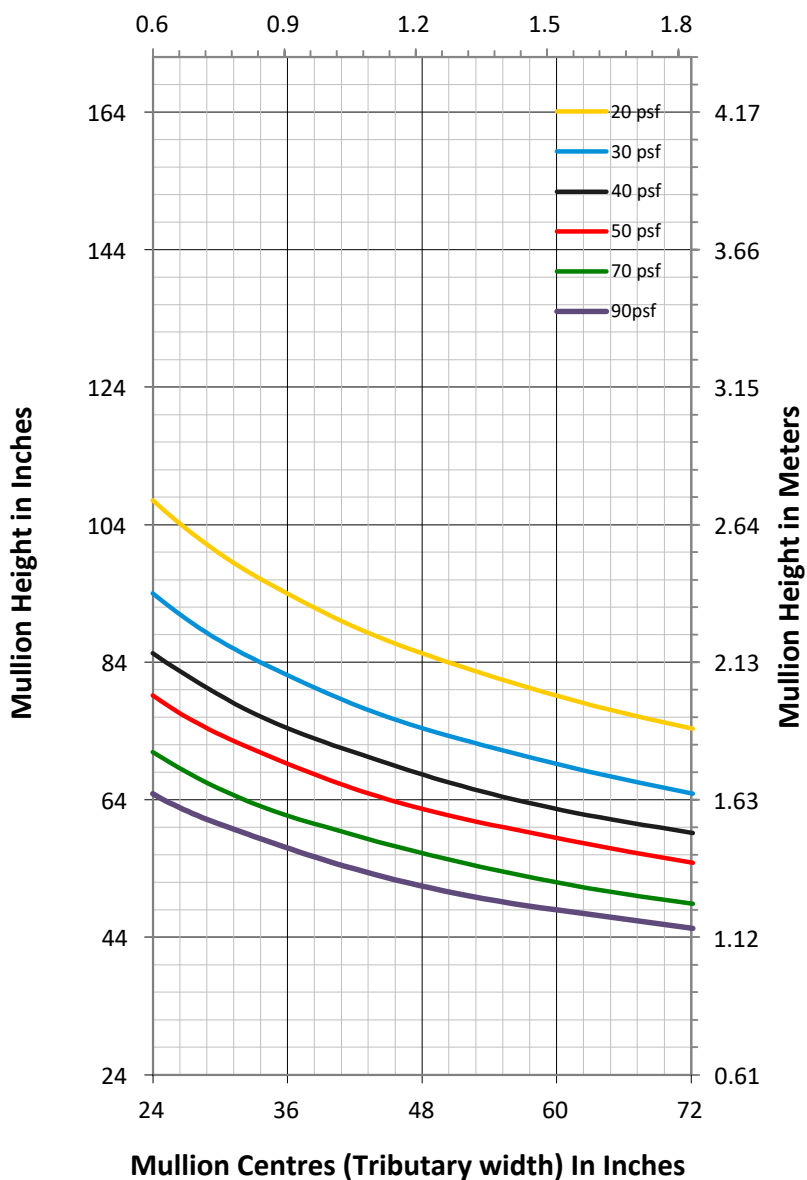

MULLION SECTION

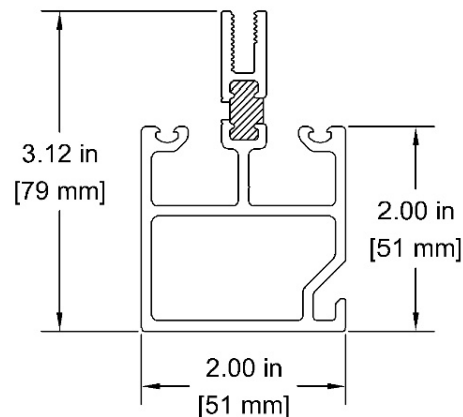

SYSTEM PROPERTIES

Moment of Inertia, Section Modulus & Area

Moment of Inertia, Ixx	Ixx = 0.95 in ⁴
Section Modulus, Sxx	Sxx = 0.52 in ³
Total Area	A = 1.23 in ²

Modulus of Elasticity

Aluminum	10,000,000 PSI
Steel	29,000,000 PSI

GENERAL NOTES

1. Deflection Limit: L/175 up to 13.5ft, L/240 + 0.25" over 13.5ft
2. Assume horizontal members provide lateral support
3. Steel moment of inertia converted to polyester, vinyl or aluminum equivalent
4. The design pressure (psf) shall be determined using the controlling load combination of dead, wind, live, and snow loads as applicable.

WIND LOAD CHART FOR 3400T SERIES - PART # 3425T

SPAN CHART

SPAN CHART IS FOR ESTIMATION ONLY.
DO NOT UTILIZE FOR DETAILED DESIGN.
CHART IS BASED ON DEFLECTION ANALYSIS
ONLY

Mullion Centres (Tributary width) In Meters

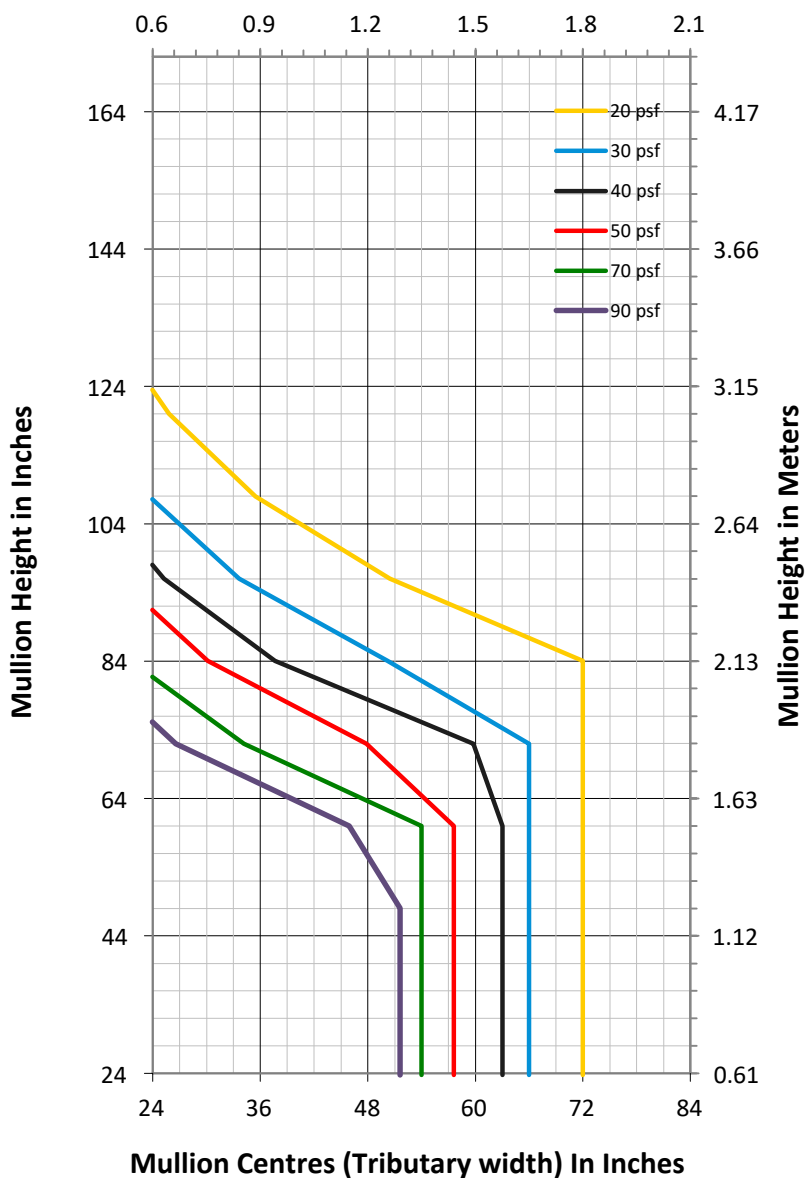

MULLION SECTION

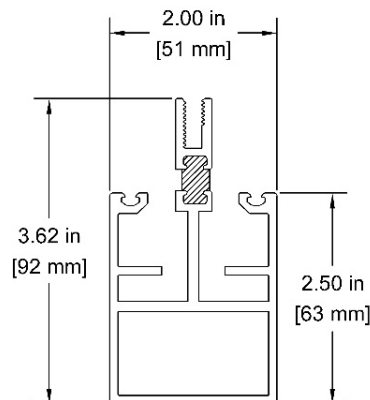

SYSTEM PROPERTIES

Moment of Inertia, Section Modulus & Area

Moment of Inertia, I_{xx}	$I_{xx} = 1.41 \text{ in}^4$
Section Modulus, S_{xx}	$S_{xx} = 0.61 \text{ in}^3$
Total Area	$A = 1.51 \text{ in}^2$

Modulus of Elasticity

Aluminum	10,000,000 PSI
Steel	29,000,000 PSI

GENERAL NOTES

1. Deflection Limit: $L/175$ up to 13.5ft, $L/240 + 0.25"$ over 13.5ft
2. Assume horizontal members provide lateral support
3. Steel moment of inertia converted to polyester, vinyl or aluminum equivalent
4. The design pressure (psf) shall be determined using the controlling load combination of dead, wind, live, and snow loads as applicable.

WIND LOAD CHART FOR 3400T SERIES - PART # 3440T

SPAN CHART

**SPAN CHART IS FOR ESTIMATION ONLY.
DO NOT UTILIZE FOR DETAILED DESIGN.
CHART IS BASED ON DEFLECTION ANALYSIS
ONLY**

Mullion Centres (Tributary width) In Meters

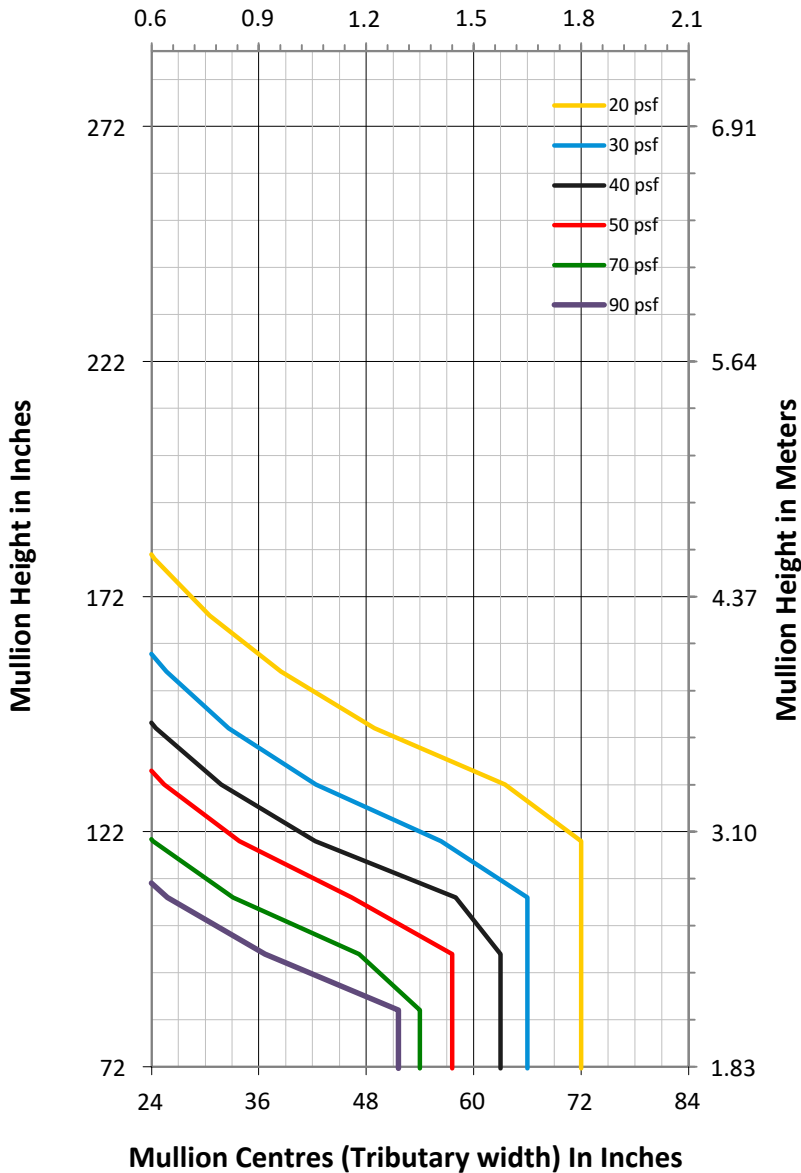

MULLION SECTION

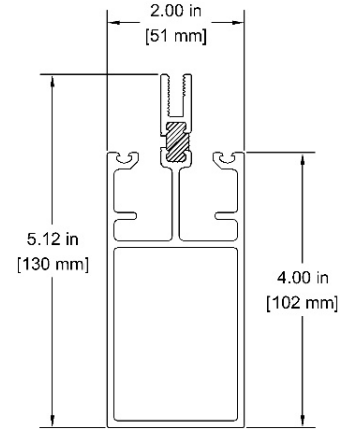

SYSTEM PROPERTIES

Moment of Inertia, Section Modulus & Area

Moment of Inertia, Ixx	Ixx = 4.62 in ⁴
Section Modulus, Sxx	Sxx = 1.20 in ³
Total Area	A = 1.92 in ²

Modulus of Elasticity

Aluminum	10,000,000 PSI
Steel	29,000,000 PSI

GENERAL NOTES

1. Deflection Limit: L/175 up to 13.5ft, L/240 + 0.25" over 13.5ft
2. Assume horizontal members provide lateral support
3. Steel moment of inertia converted to polyester, vinyl or aluminum equivalent
4. The design pressure (psf) shall be determined using the controlling load combination of dead, wind, live, and snow loads as applicable.

WIND LOAD CHART FOR 3400T SERIES - PART # 3410

SPAN CHART

SPAN CHART IS FOR ESTIMATION ONLY.
DO NOT UTILIZE FOR DETAILED DESIGN.
CHART IS BASED ON DEFLECTION ANALYSIS
ONLY

Mullion Centres (Tributary width) In Meters

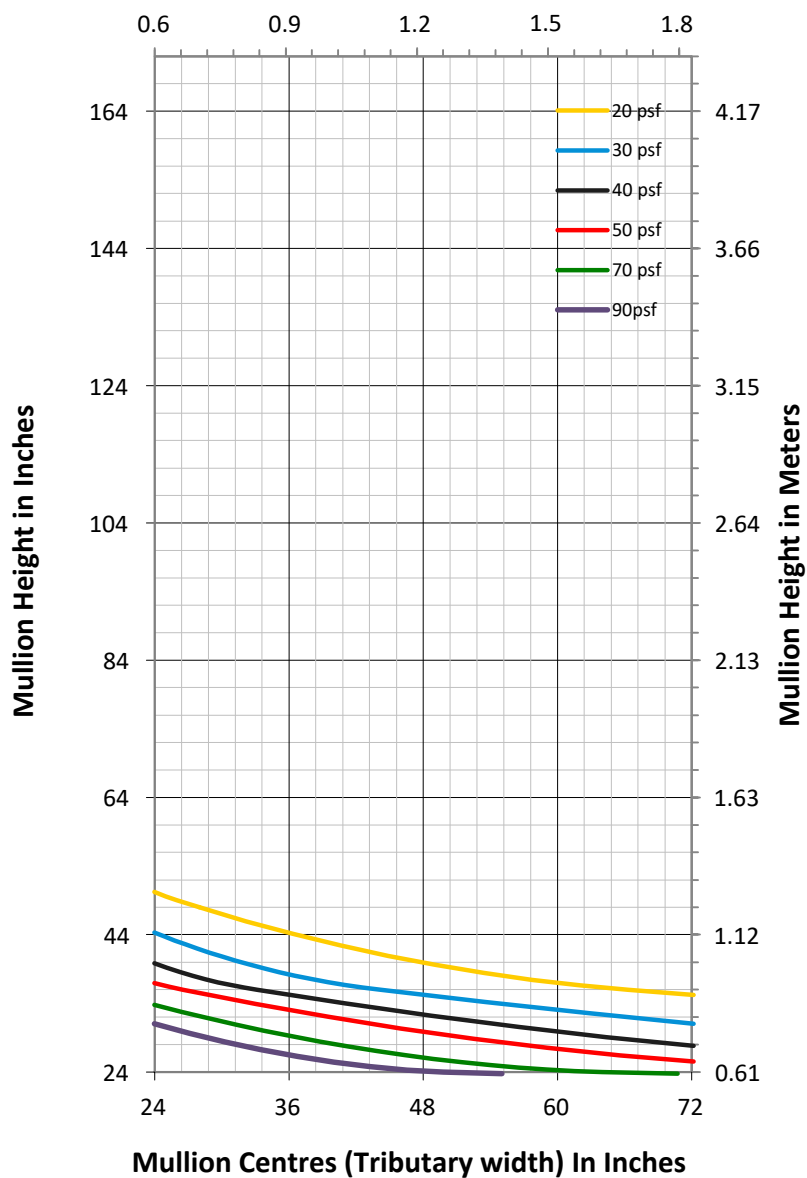

MULLION SECTION

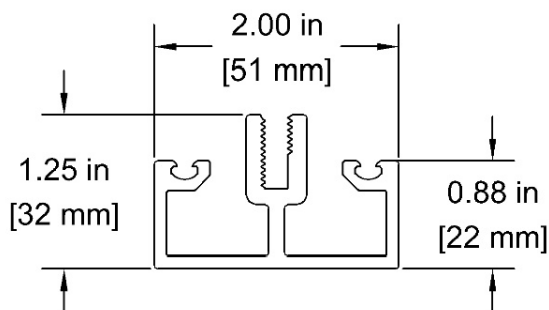

SYSTEM PROPERTIES

Moment of Inertia, Section Modulus & Area

Moment of Inertia, I _{xx}	I _{xx} = 0.10 in ⁴
Section Modulus, S _{xx}	S _{xx} = 0.13 in ³
Total Area	A = 0.75 in ²

Modulus of Elasticity

Aluminum	10,000,000 PSI
Steel	29,000,000 PSI

GENERAL NOTES

1. Deflection Limit: L/175 up to 13.5ft, L/240 + 0.25" over 13.5ft
2. Assume horizontal members provide lateral support
3. Steel moment of inertia converted to polyester, vinyl or aluminum equivalent
4. The design pressure (psf) shall be determined using the controlling load combination of dead, wind, live, and snow loads as applicable.

WIND LOAD CHART FOR 3400T SERIES - PART # 3415

SPAN CHART

SPAN CHART IS FOR ESTIMATION ONLY.
DO NOT UTILIZE FOR DETAILED DESIGN.
CHART IS BASED ON DEFLECTION ANALYSIS
ONLY

Mullion Centres (Tributary width) In Meters

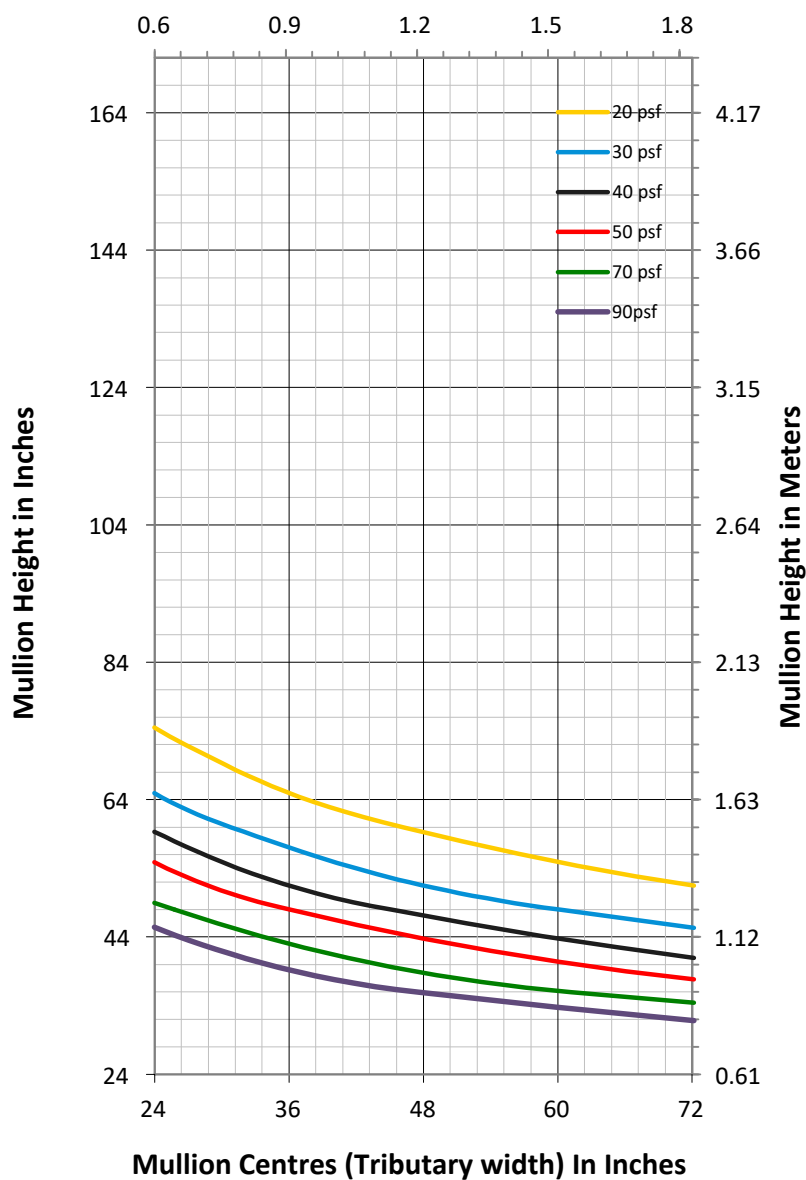

MULLION SECTION

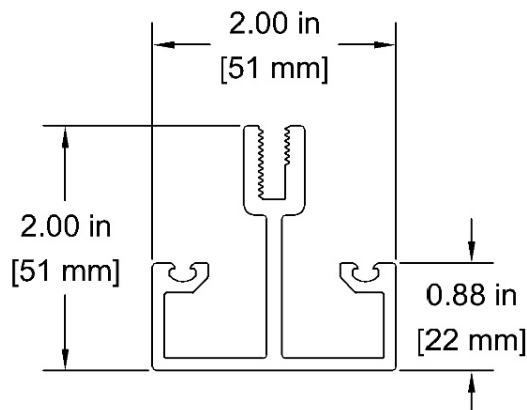

SYSTEM PROPERTIES

Moment of Inertia, Section Modulus & Area

Moment of Inertia, I_{xx}	$I_{xx} = 0.32 \text{ in}^4$
Section Modulus, S_{xx}	$S_{xx} = 0.26 \text{ in}^3$
Total Area	$A = 0.84 \text{ in}^2$

Modulus of Elasticity

Aluminum	10,000,000 PSI
Steel	29,000,000 PSI

GENERAL NOTES

1. Deflection Limit: $L/175$ up to 13.5ft, $L/240 + 0.25"$ over 13.5ft
2. Assume horizontal members provide lateral support
3. Steel moment of inertia converted to polyester, vinyl or aluminum equivalent
4. The design pressure (psf) shall be determined using the controlling load combination of dead, wind, live, and snow loads as applicable.

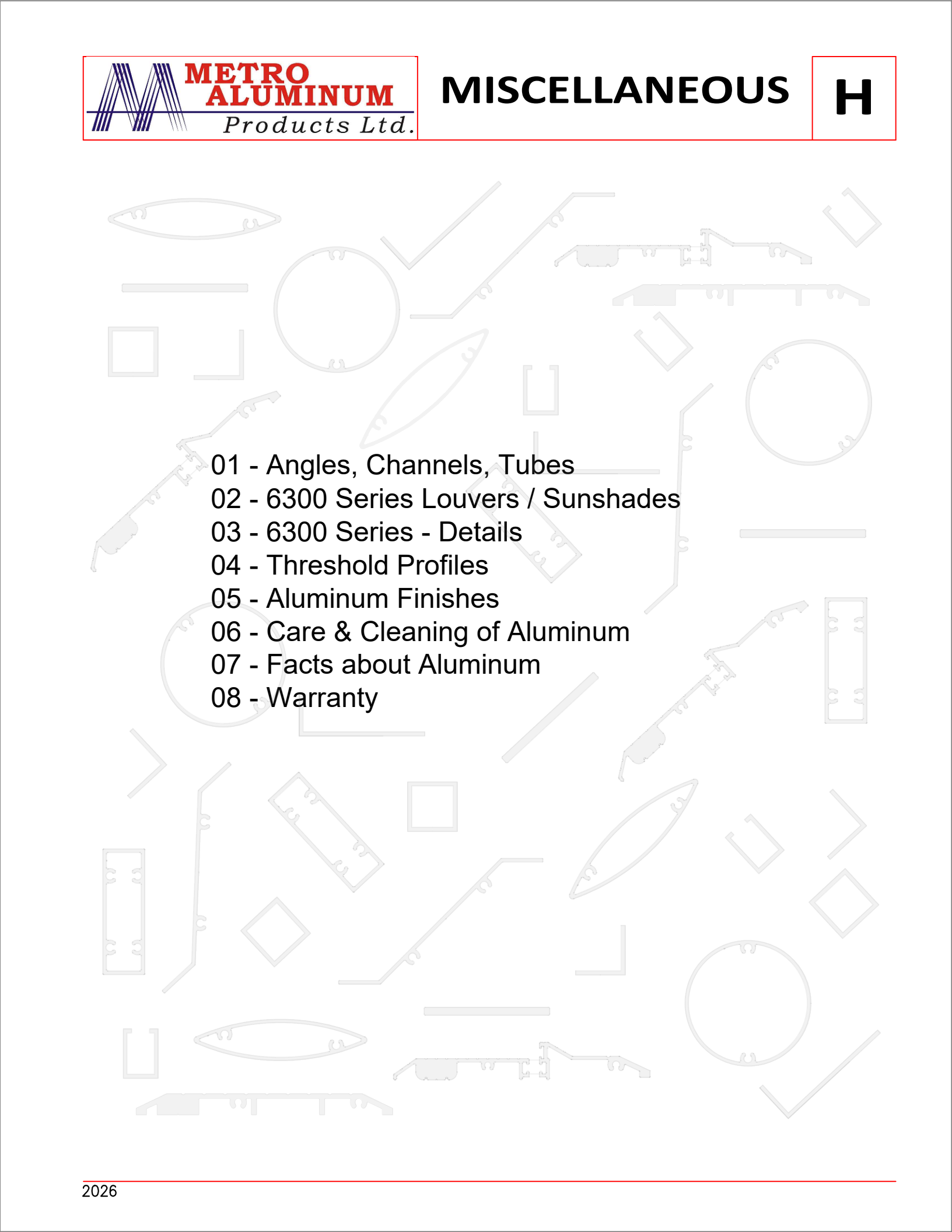
- 
- 01 - Angles, Channels, Tubes
02 - 6300 Series Louvers / Sunshades
03 - 6300 Series - Details
04 - Threshold Profiles
05 - Aluminum Finishes
06 - Care & Cleaning of Aluminum
07 - Facts about Aluminum
08 - Warranty

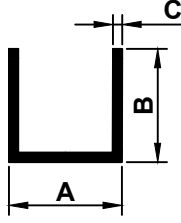
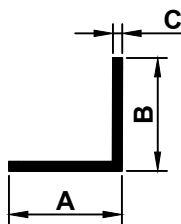
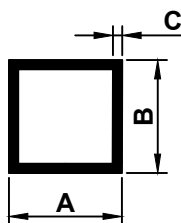
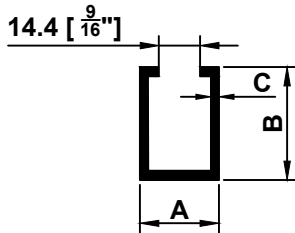

PROFILES	PART NUMBER	A	B	C
CHANNEL 	4050	12.7 0.5"	12.7 0.5"	1.5 0.06"
	4575	12.7 0.5"	19.05 0.75"	1.5 0.06"
	4075	19.05 0.75"	19.05 0.75"	1.5 0.06"
	4100	25.4 1.0"	25.4 1.0"	3.05 0.12"
	4150	38.1 1.5"	25.4 1.0"	3.05 0.12"
	4751	19.05 0.75"	25.4 1.0"	1.5 0.06"
ANGLE 	5075	19.05 0.75"	19.05 0.75"	1.5 0.06"
	5100	25.4 1.0"	25.4 1.0"	2.29 0.09"
	5102	25.4 1.0"	50.8 2.0"	3.17 0.125"
	5103	25.4 1.0"	76.2 3.0"	3.17 0.125"
TUBE 	401	44.45 1.75"	44.45 1.75"	2.29 0.09"
	402	50.8 2.0"	50.8 2.0"	2.54 0.10"
	403	63.5 2.5"	63.5 2.5"	2.41 0.095"
	405	44.45 1.75"	114.3 4.5"	2.54 0.10"
	406	50.8 2.0"	101.6 4.0"	2.41 0.095"
	407	50.8 2.0"	152.4 6.0"	2.29 0.09"
SPECIAL GLAZING CHANNELS 	4200	25.4 1.0"	25.4 1.0"	2.0 0.08"
	4201	25.4 1.0"	57.15 2.25"	2.0 0.08"

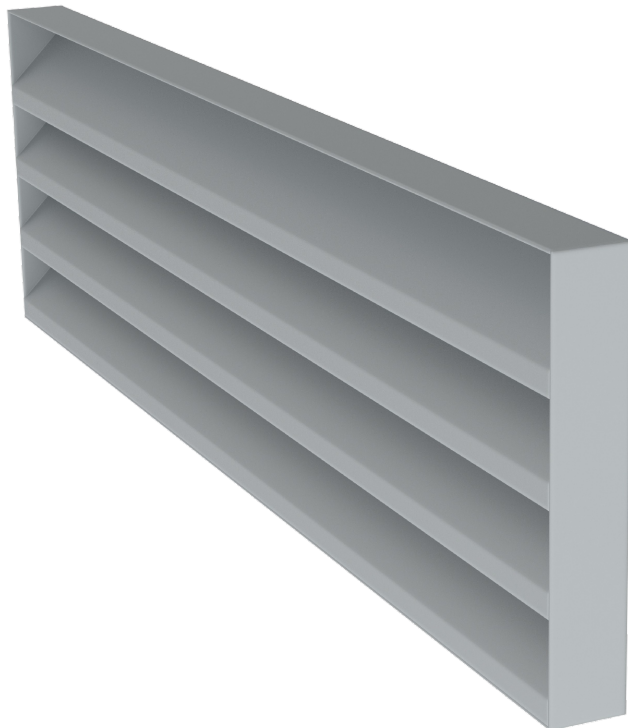

COMPONENTS

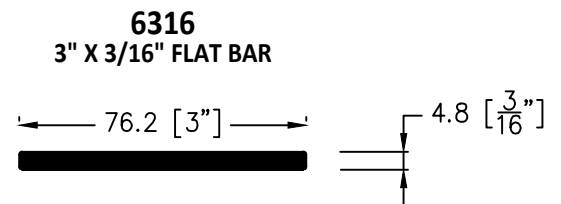
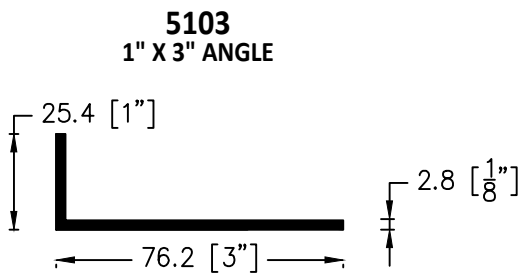
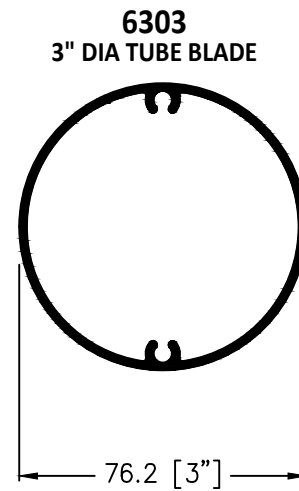
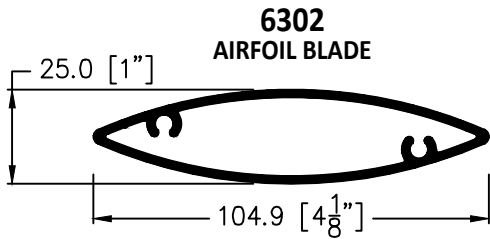
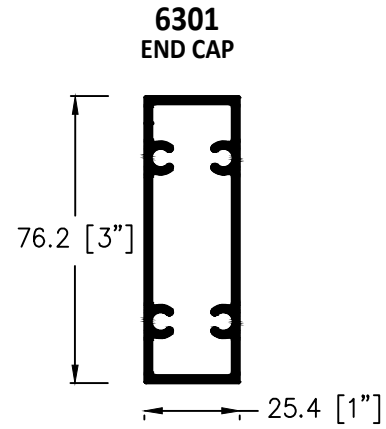
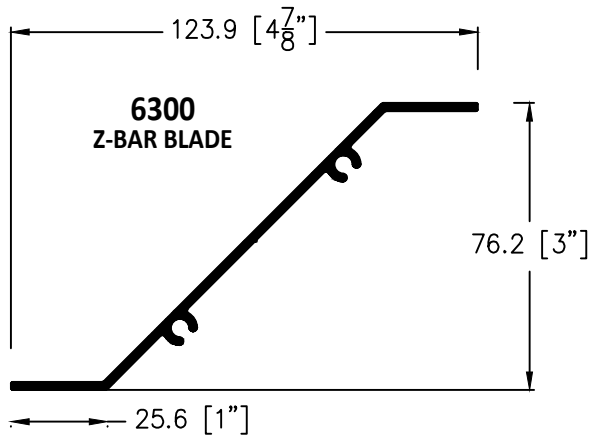

LOUVER DETAILS

CURTAIN WALL INSTALL

STOREFRONT / ROUGH OPENING INSTALL

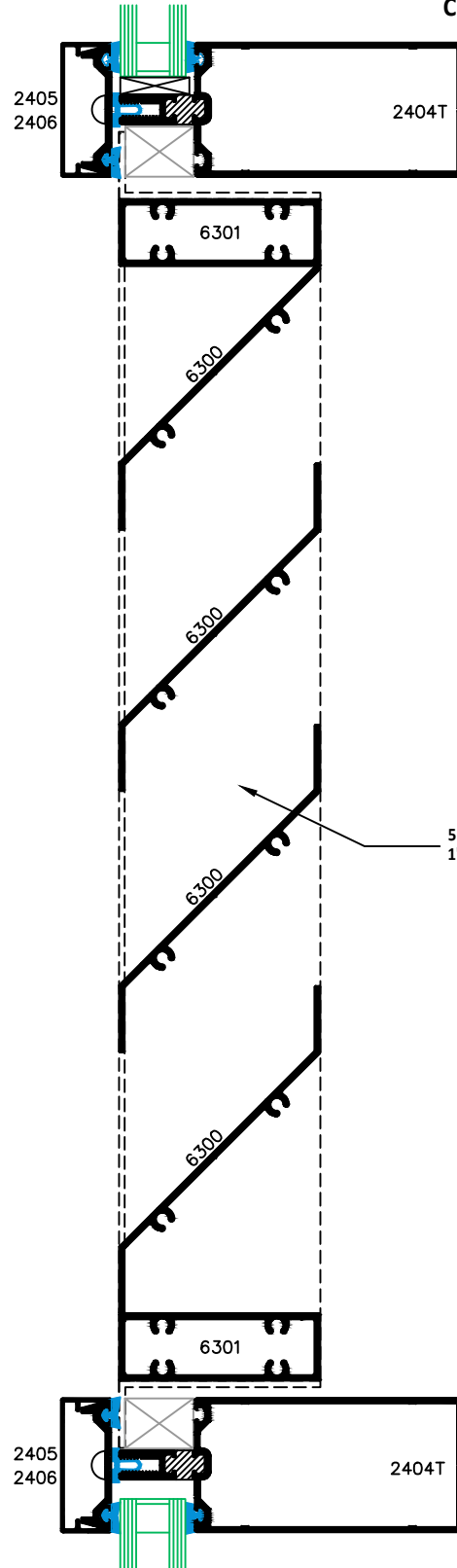
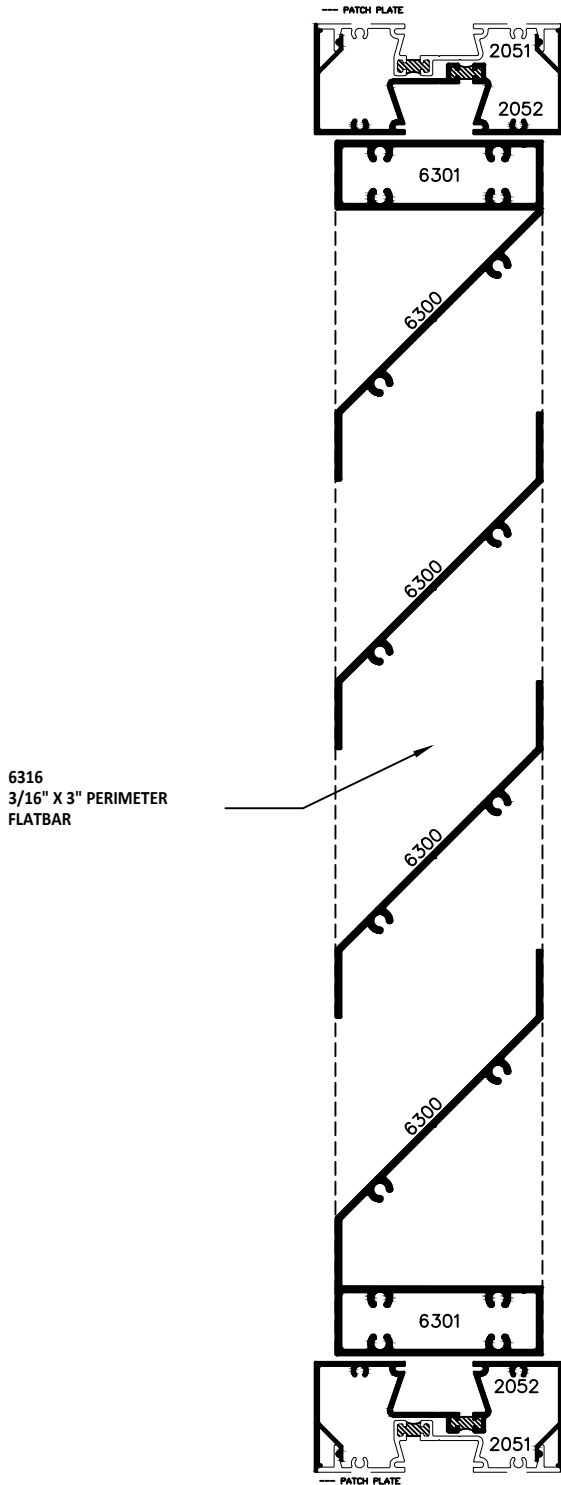

SUNSHADE DETAILS

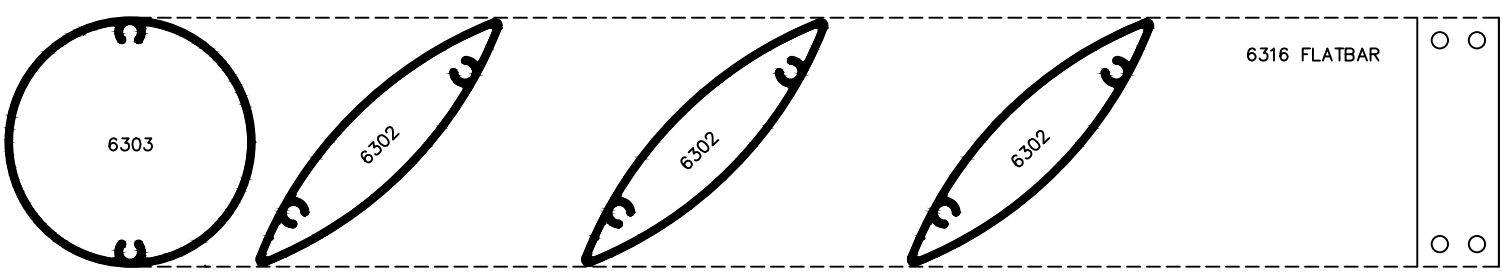
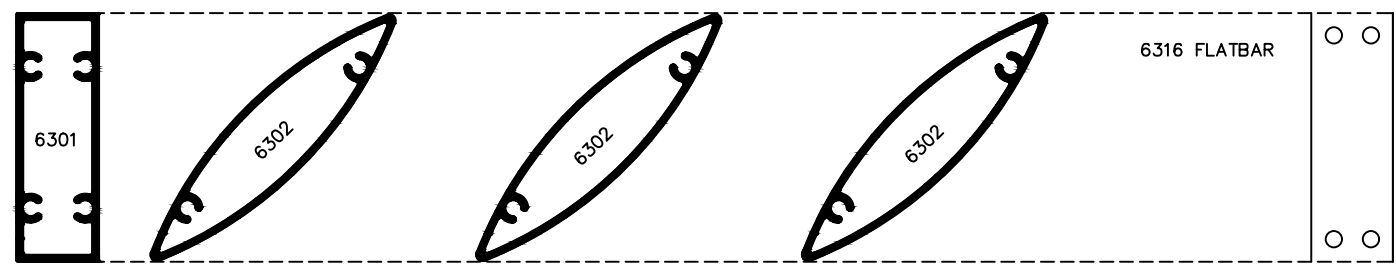
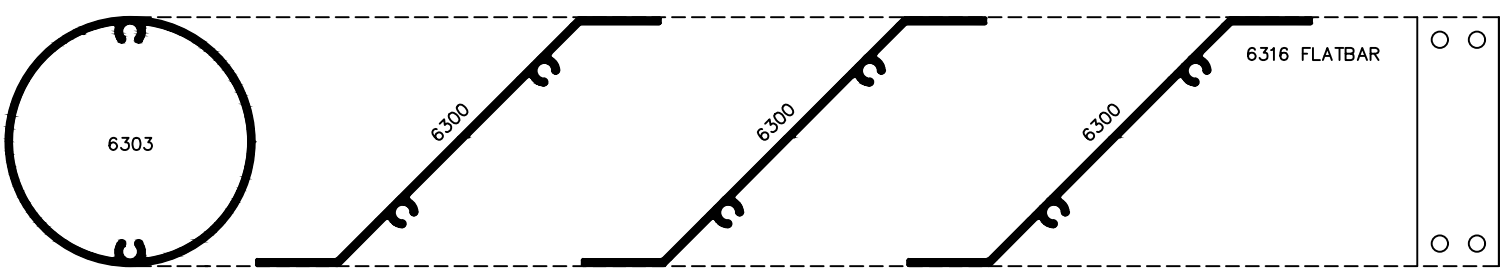
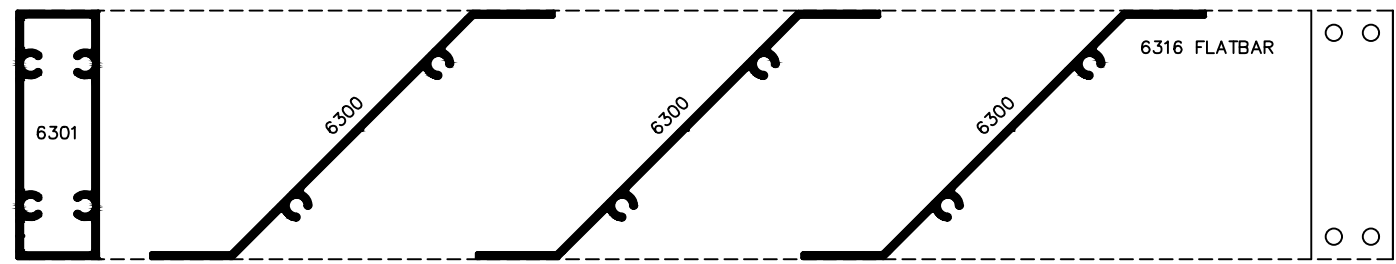

6" THRESHOLDS FOR
4 1/2" SYSTEM

1506



1506T



2106 BEVELLED



2106T SQUARE



2107T SQUARE

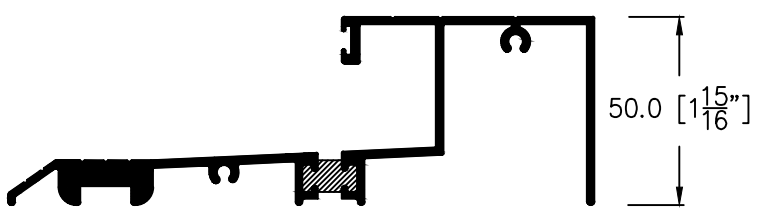

5" THRESHOLDS FOR
3 1/4" SYSTEM

1306

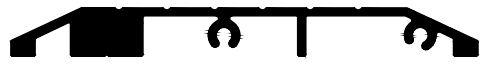

1306T



2306 BEVELLED

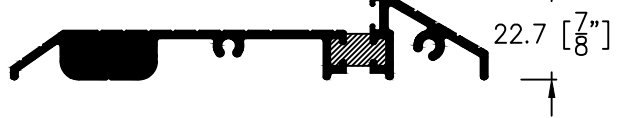

2306T SQUARE



G-2306ST SQUARE

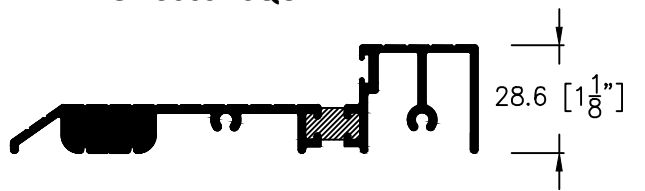

1507

7" THRESHOLDS

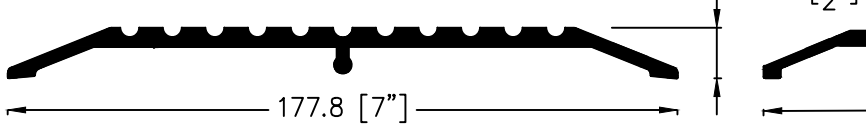

1508

8" THRESHOLDS

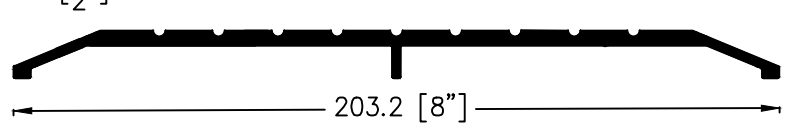

NUMERICAL LISTING OF DESIGNATIONS

MECHANICAL FINISHES (M)

AS FABRICATED

M10 - UNSPECIFIED
M11 - AS FABRICATED
M12 - NONSPECULAR AS FABRICATED
M1X - OTHER (TO BE SPECIFIED)

BUFFED

M20 - UNSPECIFIED
M21 - SMOOTH SPECULAR
M22 - SPECULAR
M2X - OTHER (TO BE SPECIFIED)

DIRECTIONAL TEXTURED

M30 - UNSPECIFIED
M31 - FINE SATIN
M32 - MEDIUM SATIN
M33 - COARSE SATIN
M34 - HAND RUBBER
M35 - BRUSHED
M3X - OTHER (TO BE SPECIFIED)

NONDIRECTIONAL TEXTURED

M40 - UNSPECIFIED
M41 - FINE MATTE
M42 - MEDIUM MATTE
M43 - ENDE MATTE
M44 - COARSE MATTE
M45 - FINE SHOT BLAST
M46 - MEDIUM SHOT BLAST
M47 - COARSE SHOT BLAST
M4X - OTHER (TO BE SPECIFIED)

CHEMICAL FINISHES (C)*

NONETCHED CLEANED

C10 - UNSPECIFIED
C11 - DEGREASED
C12 - INHIBITED CHEMICAL CLEANED
C1X - OTHER (TO BE SPECIFIED)

ETCHED

C20 - UNSPECIFIED
C21 - FINE MATTE
C22 - MEDIUM MATTE
C23 - COARSE MATTE
C2X - OTHER (TO BE SPECIFIED)

BRIGHTENED

C30 - UNSPECIFIED
C31 - HIGHLY SPECULAR ALUMINUM
C32 - DIFFUSE BRIGHT
C3X - OTHER (TO BE SPECIFIED)

CHEMICAL CONVERSION COATINGS

C40 - UNSPECIFIED
C41 - ACID CHROMATE FLOURIDE
C42 - ACID CHROMATE-NO FLUORIDE- PHOSPHATE
C43 - ALKALINE CHROMATE
C4X - OTHER (TO BE SPECIFIED)

COATING, (A, R, V, E, L)

ANODIC COATINGS (A)

GENERAL

A10 - UNSPECIFIED
A11 - PREPARATION FOR OTHER APPLIED COATINGS
A12 - CHROMIC ACID ANODIC COATINGS
A13 - HARD, WEAR AND ABRASION RESISTANT COATINGS
A1X - OTHER (TO BE SPECIFIED)

PROTECTIVE AND DECORATIVE (COATINGS LESS THAN 0.4 MIL THICK)

A21 - CLEAR
A22 - INTEGRAL COLOUR
A23 - IMPREGNATED COLOUR
A24 - ELECTROLYTICALLY DEPOSITED COLOUR
A2X - OTHER (TO BE SPECIFIED)

ARCHITECTURAL CLASS 11** (0.4 - 0.7 MIL COATINGS)

A31 - CLEAR
A32 - INTEGRAL COLOUR
A33 - IMPREGNATED COLOUR
A34 - ELECTROLYTICALLY DEPOSITED COLOUR
A3X - OTHER (TO BE SPECIFIED)

ARCHITECTURAL CLASS 1** (0.7 MIL AND THICKER ANODIC COATINGS)

A41 - CLEAR
A42 - INTEGRAL COLOUR
A43 - IMPREGNATED COLOUR
A44 - ELECTROLYTICALLY DEPOSITED COLOUR
A4X - OTHER (TO BE SPECIFIED)

**ALUMINUM ASSOCIATION STANDARDS FOR ANODIZED ARCHITECTURAL ALUMINUM

RESINOUS AND OTHER ORGANIC COATINGS (R) ***

R10 - UNSPECIFIED
R1X - OTHER (TO BE SPECIFIED)

VITREOUS COATINGS (PORCELAIN AND CERAMIC TYPES) (V) ***

V10 - UNSPECIFIED
V1X - OTHER (TO BE SPECIFIED)

ELECTROPLATED AND OTHER METAL COATINGS (E) ***

E10 - UNSPECIFIED
E1X - OTHER (TO BE SPECIFIED)

LAMINATED COATINGS (L) ***

(INCLUDES VENEERS, PLASTIC COATINGS AND FILMS BONDED TO ALUMINUM)

L10 - UNSPECIFIED
L1X - OTHER (TO BE SPECIFIED)

*** THESE DESIGNATIONS MAY BE USED UNTIL MORE COMPLETE SERIES OF DESIGNATIONS ARE DEVELOPED FOR THESE COATINGS

GENERAL INFORMATION

CLEANING AND MAINTENANCE OF ALUMINUM

Cleaning procedures should be initiated as soon as is practical after installation to remove construction and accumulated environmental dirt. Cleaning should start at the top of the building and proceed to grade in a continuous drop. For light soiling the simplest procedure is to flush the surface with water, using a moderate pressure. Progressively stronger cleaning methods may be required depending on the severity of the contamination. A small area should be tested first to check the suitability of the method and/or materials used. The aluminum finish can be damaged by abuse or harsh chemicals. Care must be taken to ensure that no cleaning methods cause any damage to adjacent materials and sealants. Also, care must be taken to ensure that materials used to clean other building elements will not damage the aluminum finish.

PROTECTION OF ALUMINUM

Aluminum should be protected during and after installation from contact with concrete, plaster or other alkaline substances. All trades involved should be careful when around aluminum and must share in the responsibility to see that the aluminum finish is not damaged. Aluminum can be protected by covering it with plastic film or paper, or by applying a strippable plastic coating. Any contamination of the aluminum by construction materials should be cleaned immediately to prevent damage to the finish.

ISOLATION COATINGS

When aluminum is in direct contact with steel or certain other metals in the presence of an electrolyte, galvanic corrosion of the aluminum can occur in the vicinity of the contact area. To prevent this corrosion, an isolation coating should be applied to the ferrous material, to serve as an electrical insulator between the two metals. Also, where raw aluminum is in contact with concrete, plaster or other alkaline substance a coating should be applied to the aluminum to protect it from attack. The most frequent coating specified and used for these purposes is bituminous paint. It is a low cost asphalt or coal tar derivative with excellent water resistance and good resistance to salts, oxides and alkalis.

THE FACTS ABOUT ALUMINUM WINDOWS

FACT #1

Unmatched Strength and Stability in Any Climate

Pound for pound, aluminum is one of the strongest and most reliable materials available for window frames. It stands up exceptionally well to the extreme temperature swings common in northern climates. Unlike other materials that expand, contract, warp, or crack with seasonal changes, aluminum retains its shape and strength year after year.

Its structural rigidity makes aluminum windows more resistant to deformation caused by building movement and climate stress. In fact, aluminum expands and contracts 2.6 times less than vinyl and doesn't swell or shrink like wood. This means a better long-term fit within the window opening, improved weather sealing, and greater energy efficiency. Simply put, your windows will last longer—and so will your investment.

FACT #2

Industry-Leading Energy Efficiency

Aluminum is an ideal material for building high-performance, energy-efficient windows. It's easy to work with, highly machinable, and allows for precise fabrication, ensuring parts fit tightly and securely. Today's aluminum window frames can incorporate advanced thermal barriers, durable seals, and precision glazing systems that help maintain comfort and reduce energy costs.

Unlike some materials that degrade over time due to sun, moisture, or temperature changes, aluminum maintains its structural integrity in all climates. Combined with modern glazing options—such as Low-E coatings and gas-filled insulating glass—aluminum windows can deliver year-round energy savings.

FACT #3

More Design Flexibility for Modern Homes

Aluminum's strength-to-weight ratio makes it a favorite among designers and architects. Its rigidity allows for slimmer frames and larger glass areas, bringing in more natural light and offering a cleaner, more contemporary aesthetic.

It can be fabricated into a wide range of profiles and window styles, all engineered for smooth operation and a snug fit. Aluminum is also compatible with a wide selection of durable, low-maintenance finishes, available in a variety of standard and custom colors. Because it doesn't absorb moisture, aluminum won't rust, rot, swell, crack, or warp—ensuring it stays beautiful for decades.

FACT #4

A Strong Future Built on a Proven Material

Aluminum has been used in building and construction since the 1870s, and its potential continues to grow. As one of Earth's most abundant elements, it's not only sustainable but also one of the most recyclable and energy-efficient materials to produce.

Organizations like the Aluminum Extruders Council (AEC) are driving innovation in aluminum manufacturing, working closely with builders, fabricators, and consumers to expand its use and efficiency. Their mission: to promote the benefits of aluminum and ensure it remains a vital material for tomorrow's buildings. With its unmatched strength, versatility, and sustainability, aluminum is here to stay.

WARRANTY

METRO ALUMINUM PRODUCTS LTD. warrants that their products shall be free from defects in workmanship and materials to generally accepted industry standards for a period of one year from the date of shipment provided that they have been installed and maintained in accordance with METRO ALUMINUM PRODUCTS LTD. installation instructions and recommendations. This warranty is limited to defects appearing within one year from the date of shipment and provided that written notification defining defects is received by METRO ALUMINUM PRODUCTS LTD. within that one year period. This warranty is limited to the repair or replacement of defective materials or the repayment by METRO ALUMINUM PRODUCTS LTD. of the original purchase price paid for the defective material: METRO ALUMINUM PRODUCTS LTD. reserves the right to select any of the above options.